

LAND ROVER

Driving Lamp Kit *FITTING INSTRUCTION*

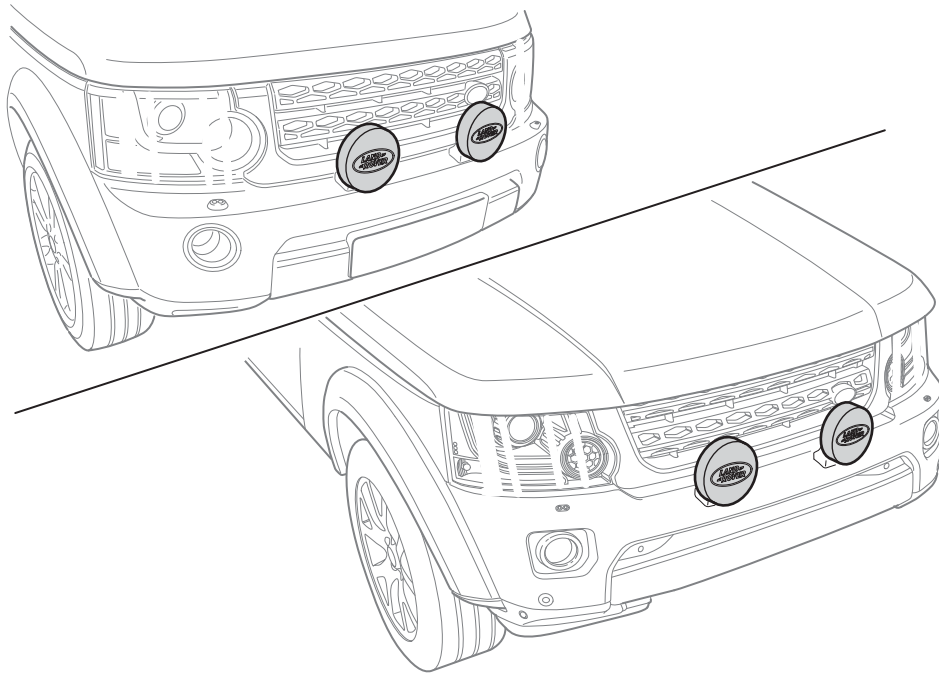

安装说明
煞车灯套件

EINBAUANLEITUNG
Fahrscheinwer fersatz

INSTRUCTION DE MONTAGE
Kit de phares-route

ISTRUZIONI PER L'USO
Corredo fari di guida

INSTRUCCION DE MONTAJE
Kit de faros de conducción

INSTRUÇÕES DE MONTAGEM
Verstralerset

Инструкции по установке
Боковые трубки из нержавеющей стали

MONTAGEHANDLEIDING
Roestvrijstalen zijbuizen

取付用マニュアル
ドライビングランプキット



WARNING!

Accessories which are not properly fitted can be dangerous. Read the instructions carefully prior to fitting. Whilst fitting, comply with instructions at all times. If in doubt, contact your nearest approved dealer.

警告!

未恰当地安装配件将造成安全隐患。安装前，请仔细阅读说明书。安装时，请始终遵照说明书。如有疑问，请就近联系经认可的经销商。

ACHTUNG!

Von nicht einwandfrei verstaubten Gegenständen können Gefahren ausgehen. Vor dem Einbau die Anleitung sorgfältig lesen. Während des Einbaus immer die Anleitung beachten. Im Zweifelsfall einen Vertragspartner zu Rate ziehen.

AVERTISSEMENT!

Les accessoires montés de manière incorrecte peuvent présenter un danger. Lire attentivement les instructions avant de procéder au montage. Se référer systématiquement aux instructions pendant le montage. En cas de doute, contacter le concessionnaire agréé le plus proche.

AVVERTENZA!

Gli accessori non montati correttamente possono essere pericolosi. Leggere attentamente le istruzioni prima del montaggio. Durante il montaggio, attenersi scrupolosamente alle istruzioni. In caso di dubbi, contattare il concessionario più vicino.

ADVERTENCIA!

Los accesorios que no encajen correctamente pueden ser peligrosos. Lea detenidamente las instrucciones antes de proceder al montaje. Durante el montaje, siga las instrucciones en todo momento. Si tiene alguna duda, póngase en contacto con el concesionario oficial más cercano.

AVISO!

Os acessórios montados inadequadamente podem ser perigosos. Leia cuidadosamente as instruções antes da montagem. Durante a montagem, siga sempre as instruções. Em caso de dúvida, contacte o concessionário autorizado mais próximo.

ВНИМАНИЕ!

Неправильно установленные аксессуары могут быть опасны. Перед установкой внимательно прочитайте инструкцию. При установке не нарушайте требования инструкции. В случае возникновения вопросов обратитесь к авторизованному дилеру.

WAARSCHUWING!

Onjuiste gemonteerde accessoires kunnen risico's opleveren. Lees de instructies zorgvuldig door voordat u overgaat tot monteren. Houd u bij het monteren altijd aan de instructies. Neem bij twijfel contact op met de dichtstbijzijnde erkende dealer.

警告!

正しく取り付けられていないアクセサリは危険である。取り付ける前に、手順を注意深く読むこと。取り付け作業中は、いつでも手順書を順守すること。疑問等がある場合、近くの正規ディーラーに問い合わせること。

Fitting Instructions can be found at the URL below:

有关安装说明，请参见下方的 URL:

Für eine Einbauanleitung siehe untenstehende URL:

Les instructions de montage sont disponibles à l'adresse URL ci-dessous :

Le istruzioni di montaggio sono disponibili all'indirizzo URL seguente:

Las instrucciones de montaje se pueden encontrar en la siguiente URL:

As Instruções de Montagem encontram-se no seguinte URL:

Инструкции по установке приведены на веб-сайте по следующему адресу:

De montage-instructies vindt u op de onderstaande website:

該当手順については、以下の URL を参照:

www.ownerinfo.jaguar.com

www.ownerinfo.landrover.com

VPLAV0019

10MY VPLAV0020

14MY VPLAV0098

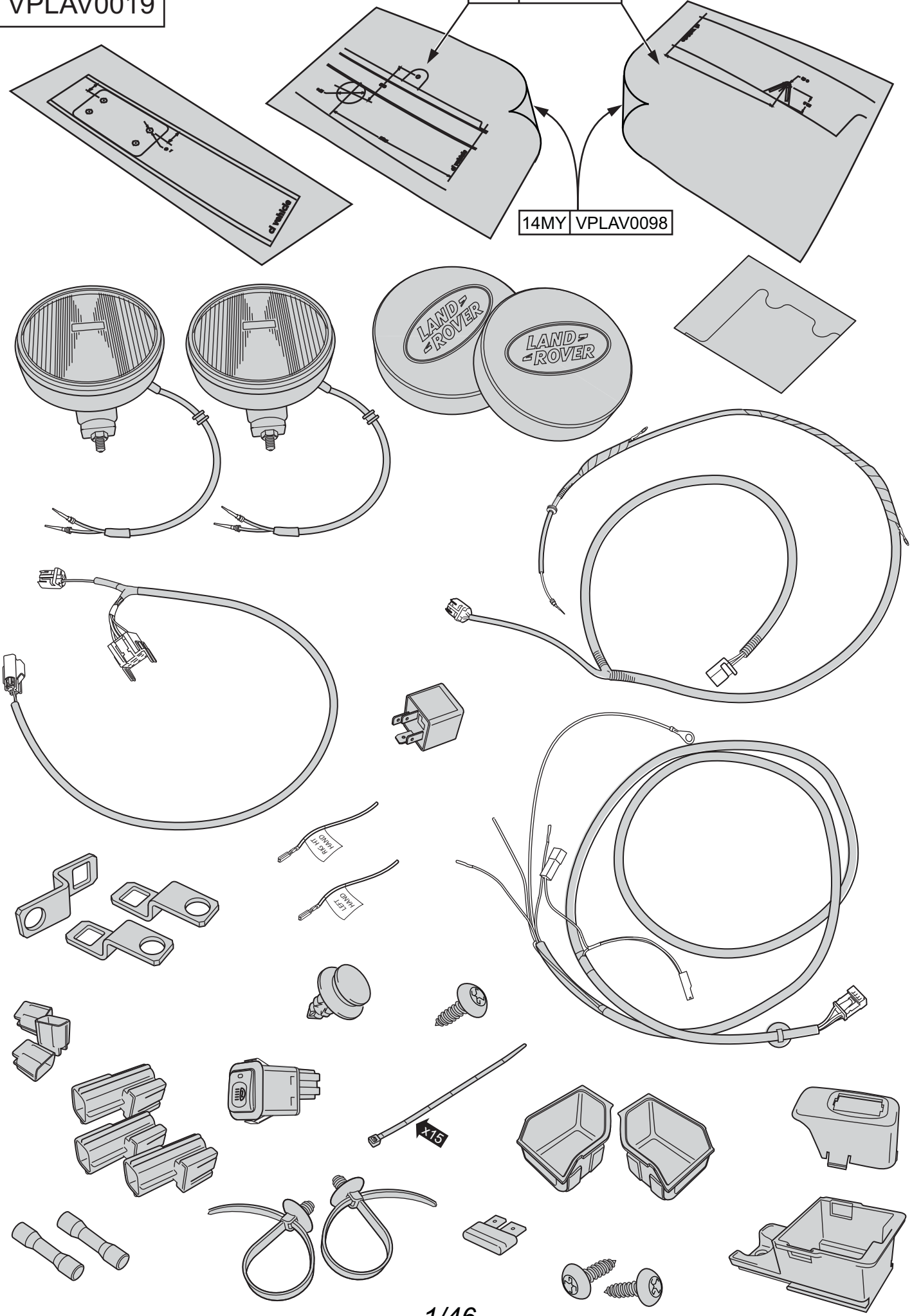

10MY VPLAV0020

14MY VPLAV0098

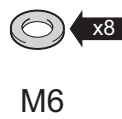
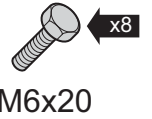
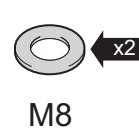
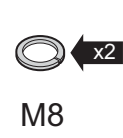
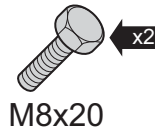
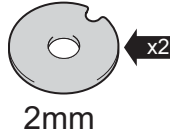
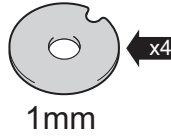
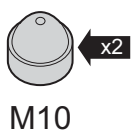
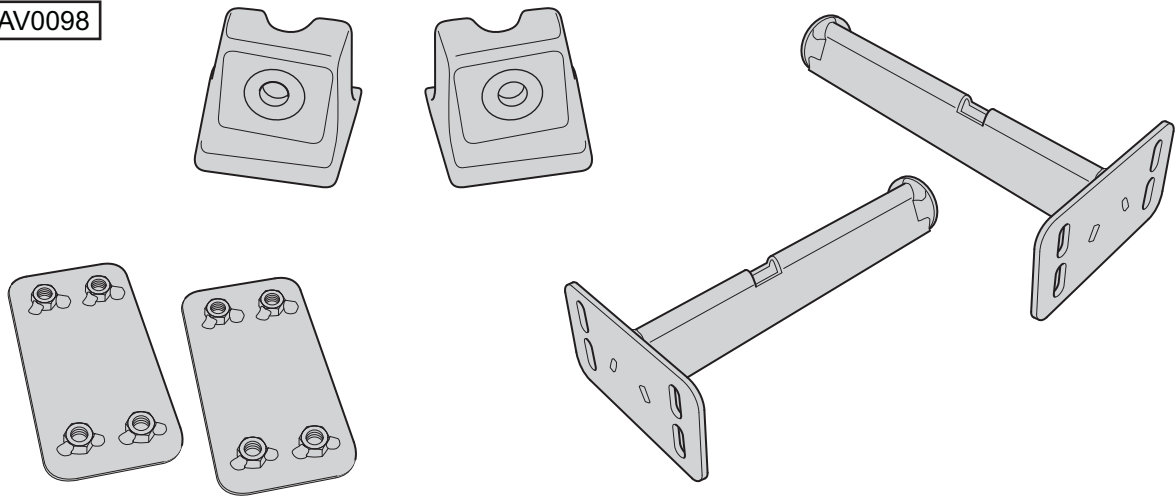

10MY VPLAV0021

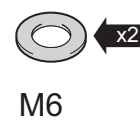
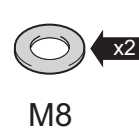
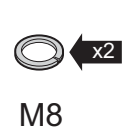
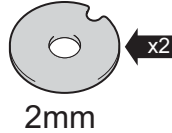
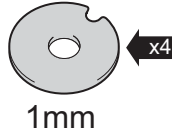
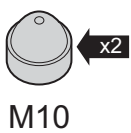
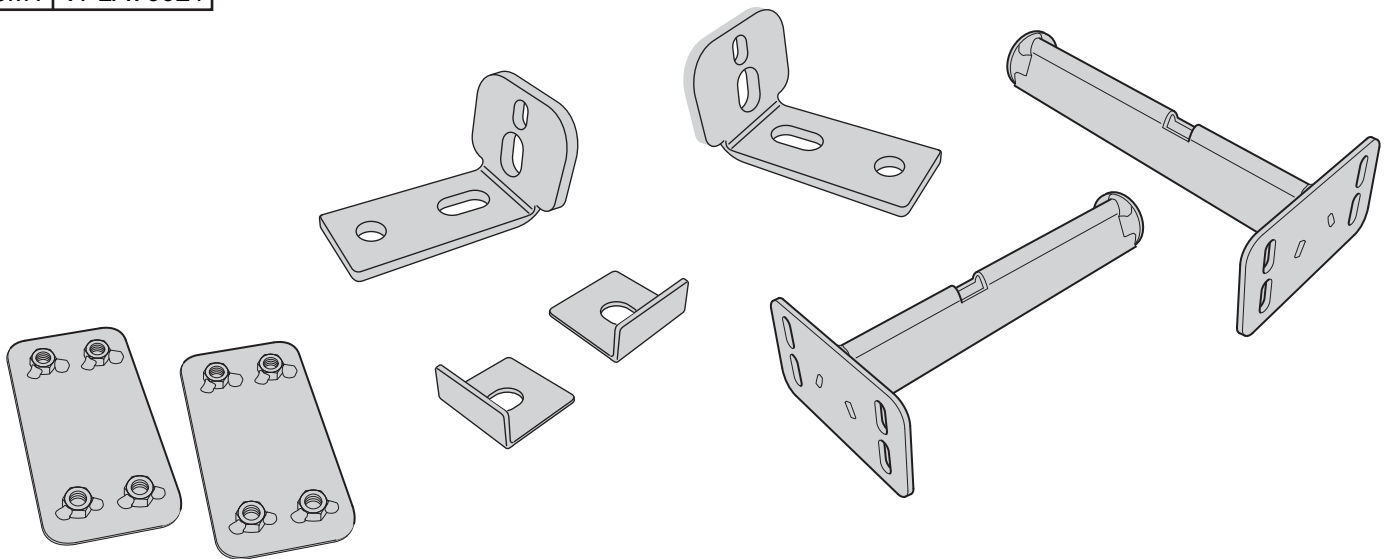

The following instructions are valid for both sides of the vehicle.

以下说明适用于车辆两侧。

Die folgenden Anweisungen gelten für beide Seiten des Fahrzeugs.

Les instructions suivantes sont valables pour les deux côtés du véhicule.

Le seguenti istruzioni sono valide per entrambi i lati del veicolo.

Las siguientes instrucciones son válidas para ambos lados del vehículo.

As instruções seguintes são válidas para ambos os lados do veículo.

Приведенные инструкции действительны для обеих сторон автомобиля.

De volgende instructies gelden voor beide zijden van het voertuig.

車両の両サイドに対して、以下の指示に従う。

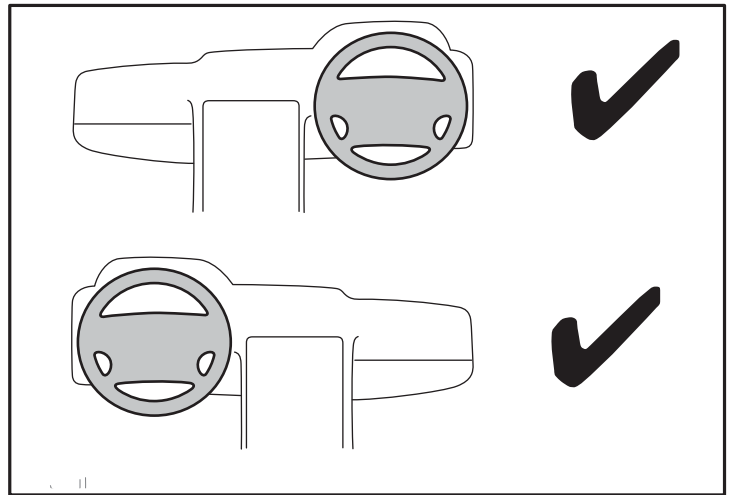

1

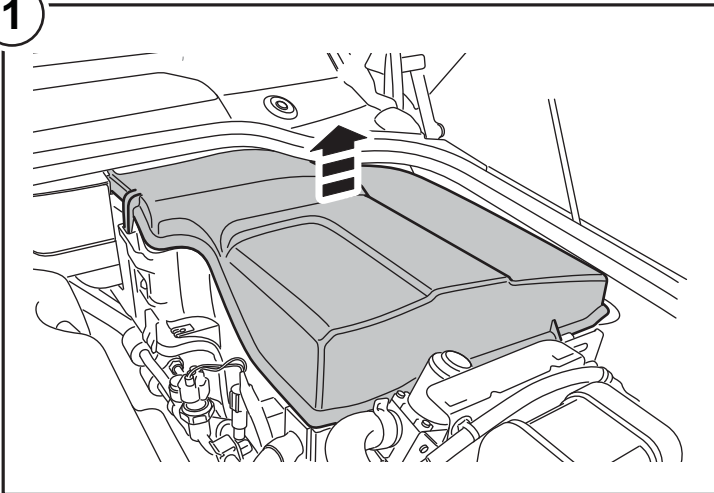

2

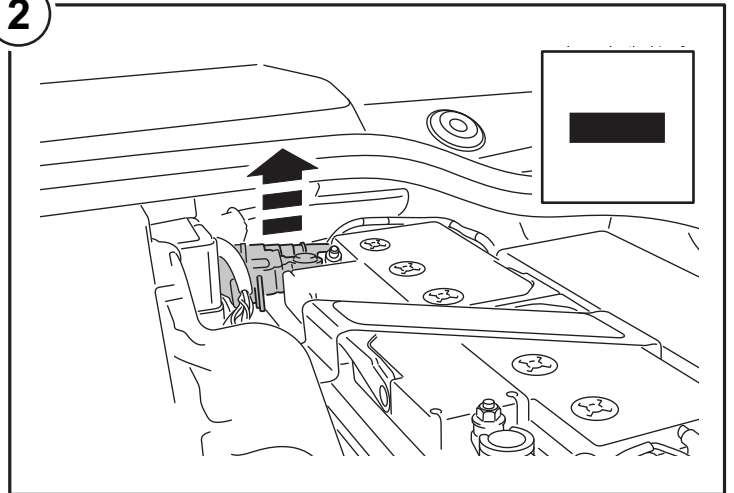

3

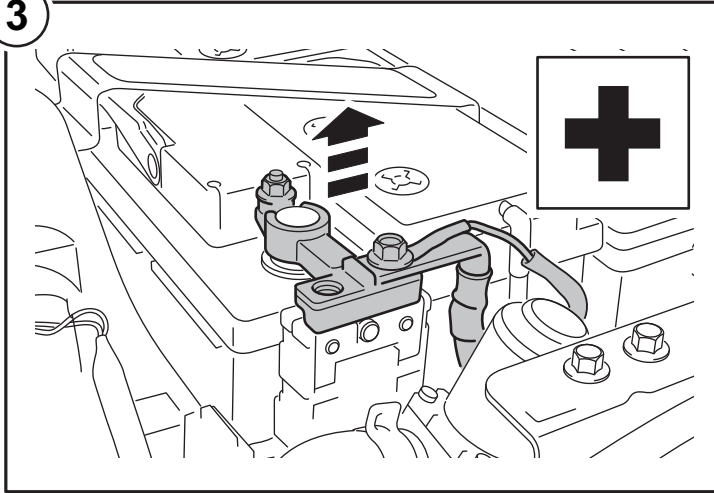

4

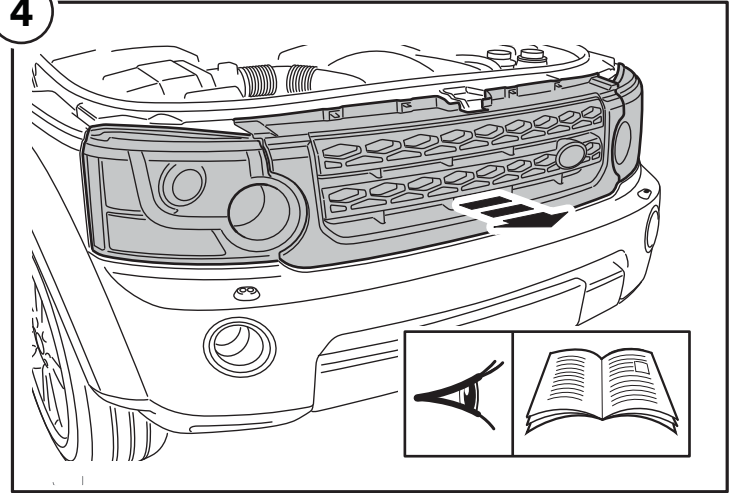

5

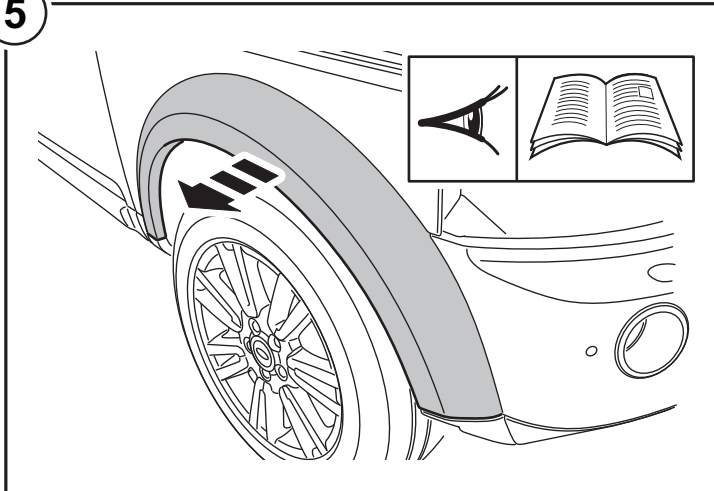

6

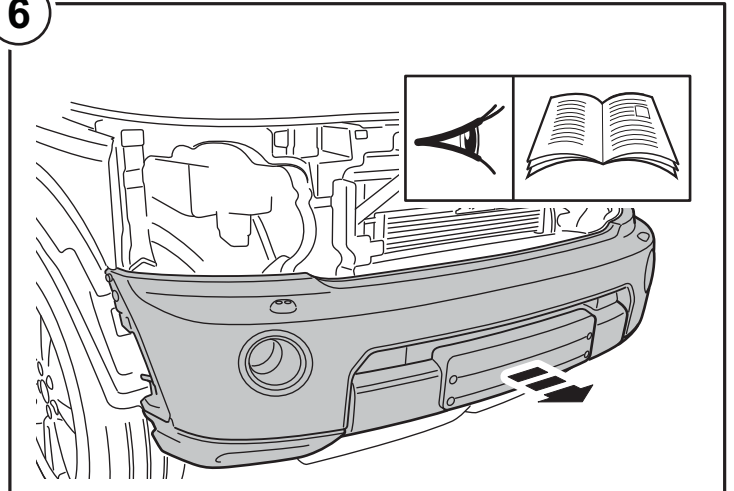

7

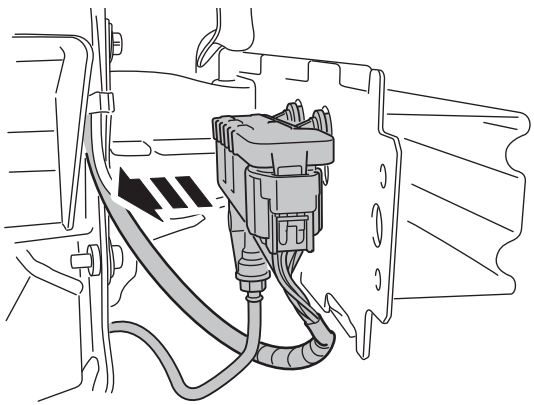

8

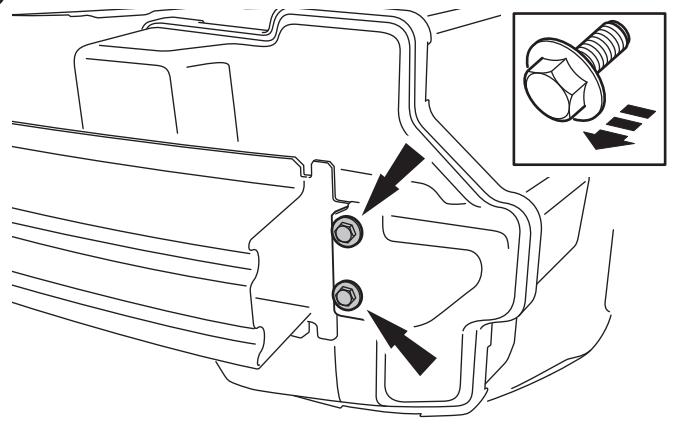

9

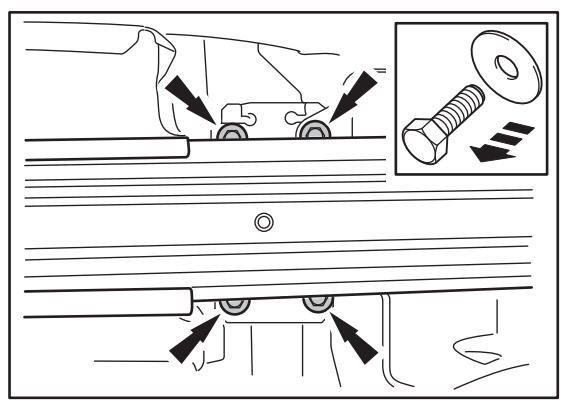
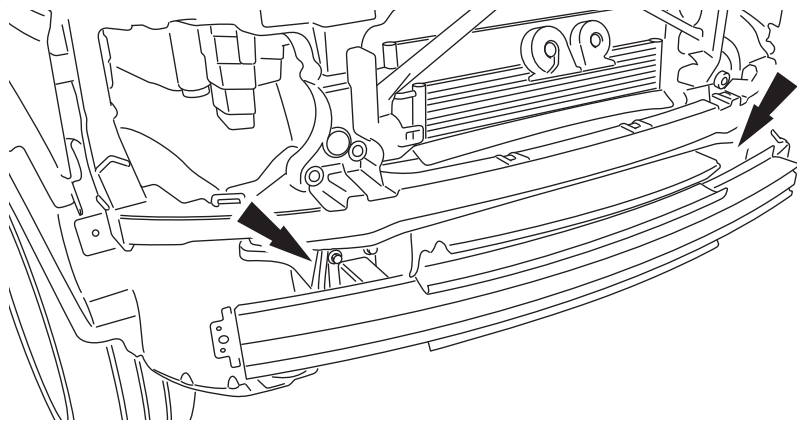

10

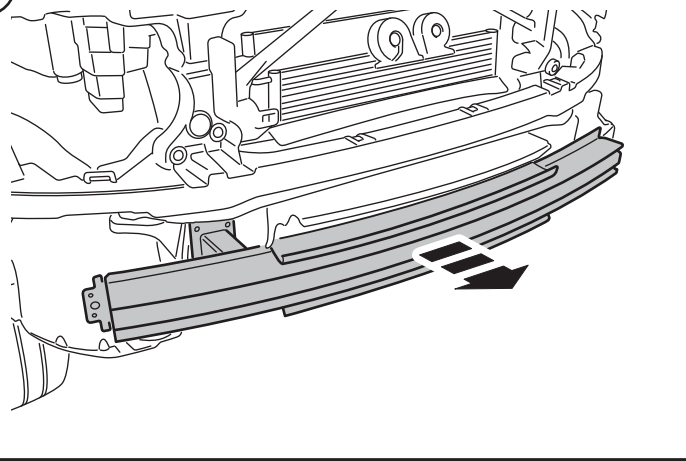

11

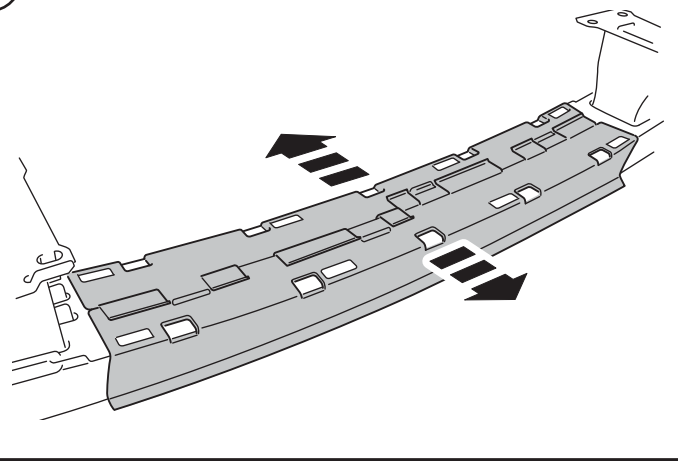

12

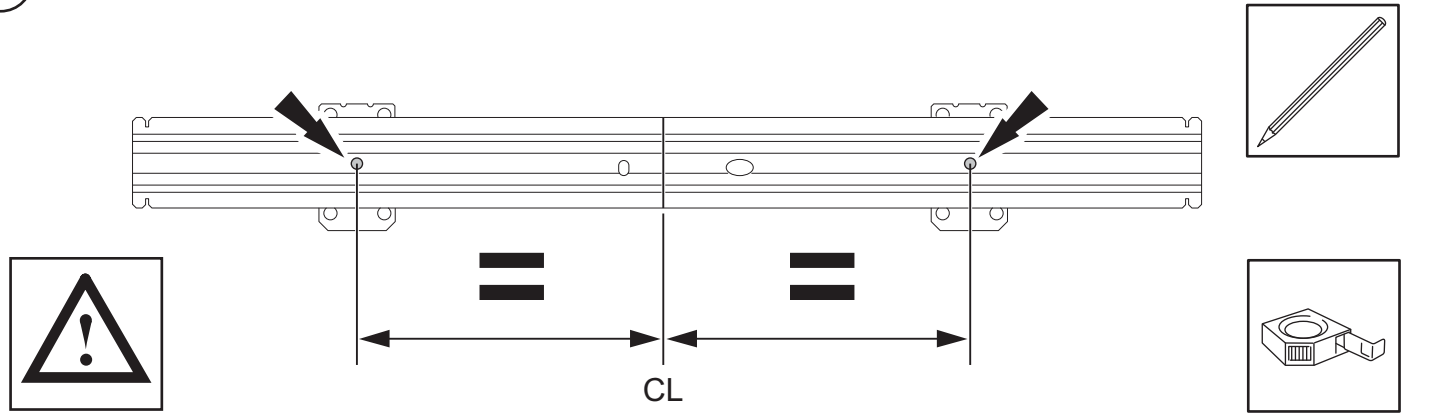

13

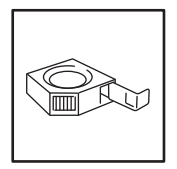
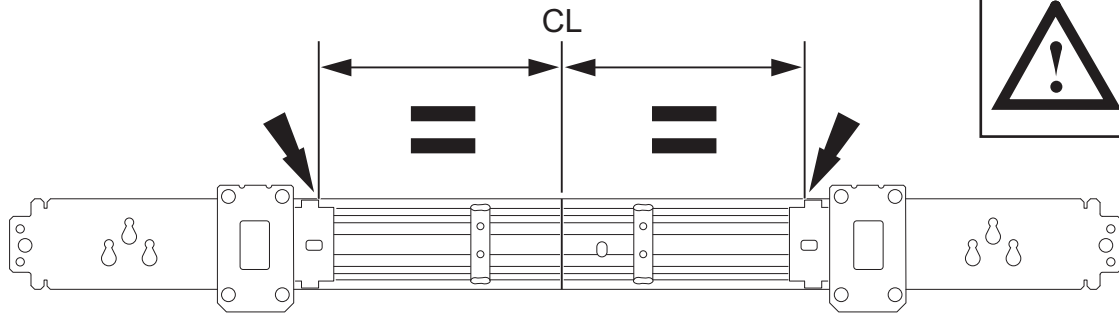

14

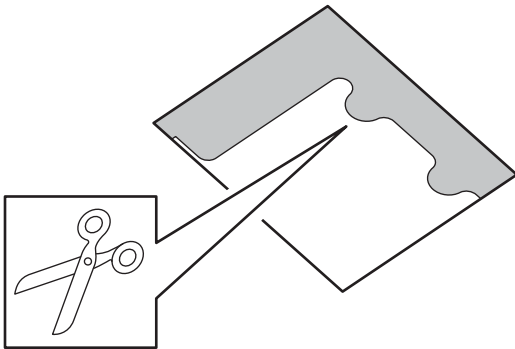

15

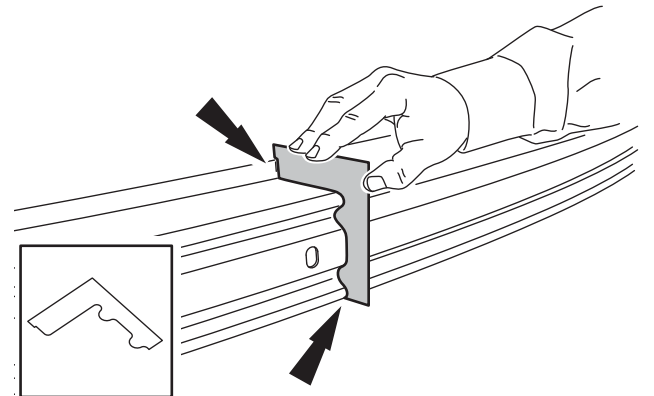

16

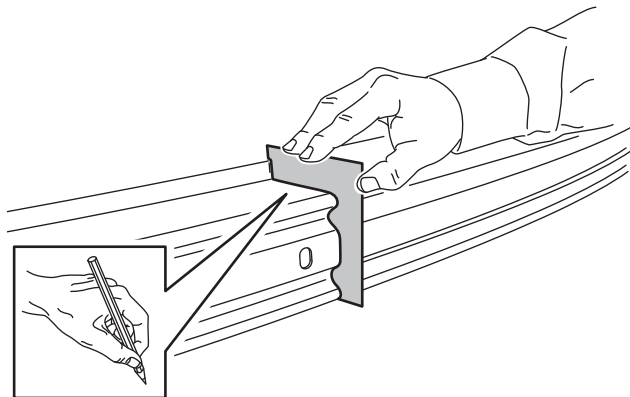

17

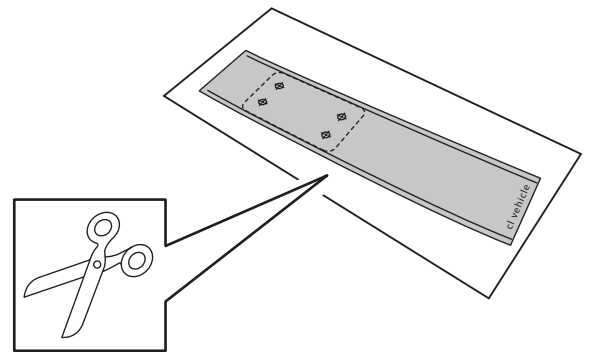

18

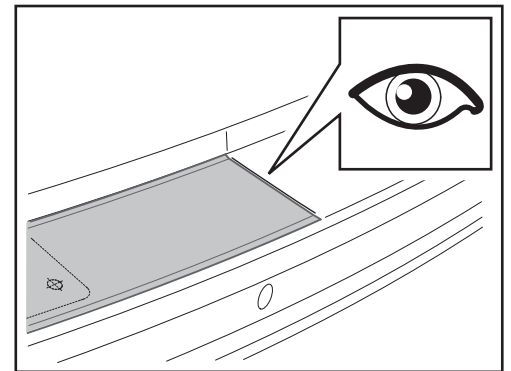
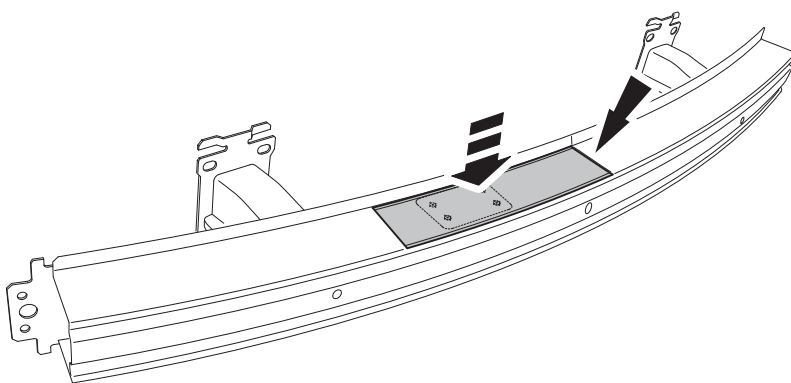

19

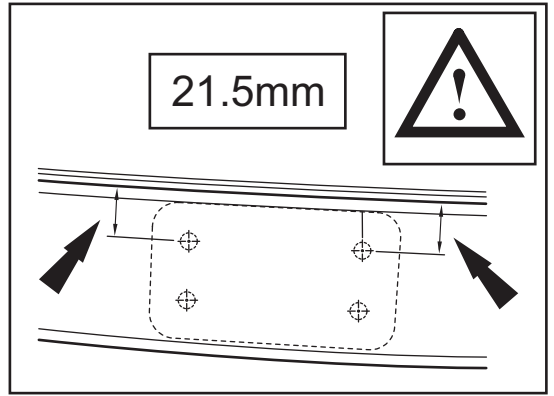
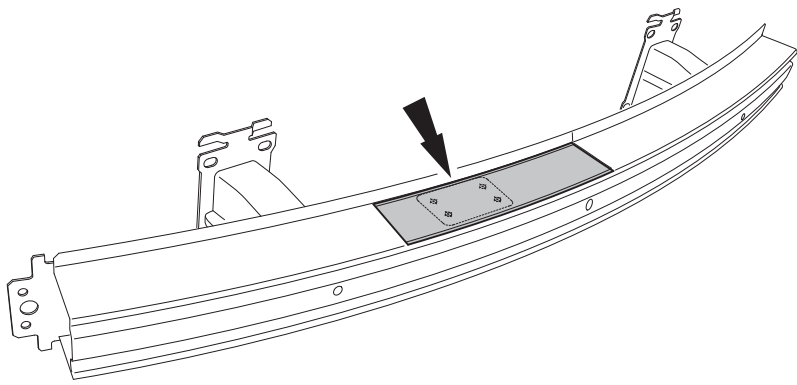

20

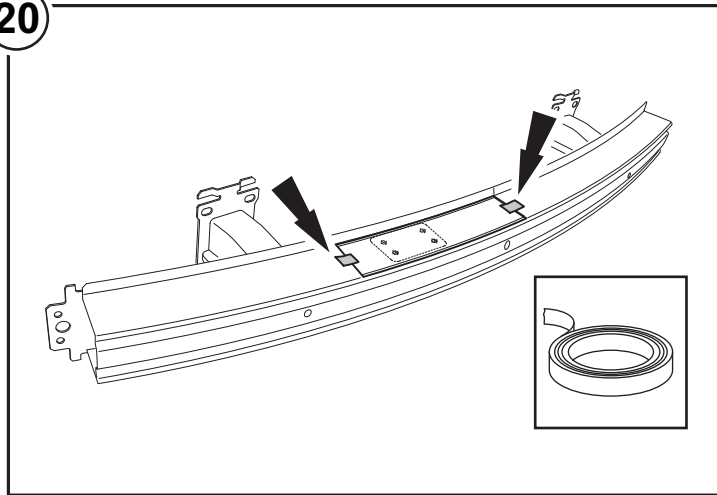

21

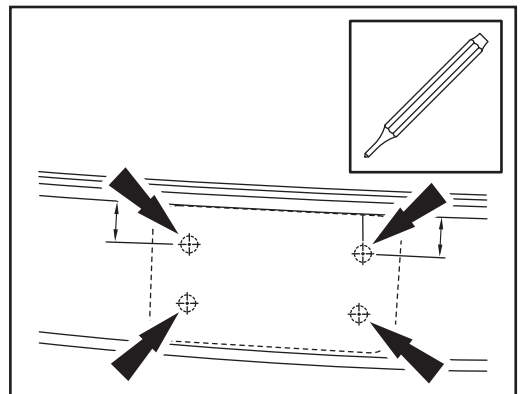
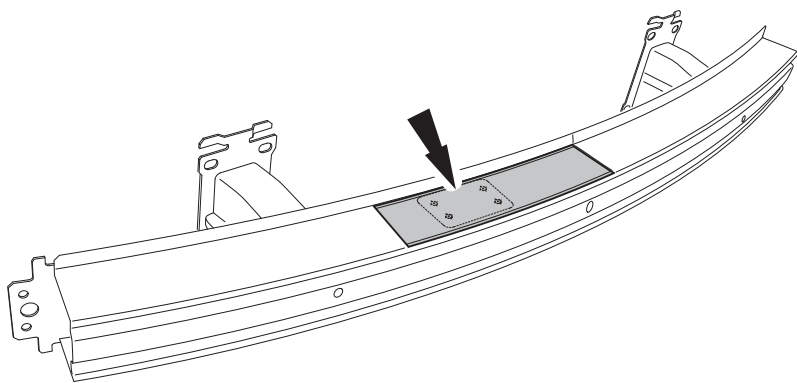

22

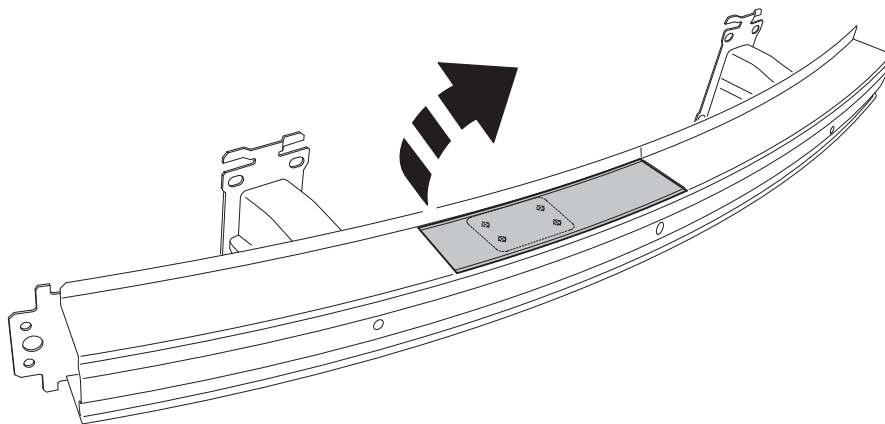

23

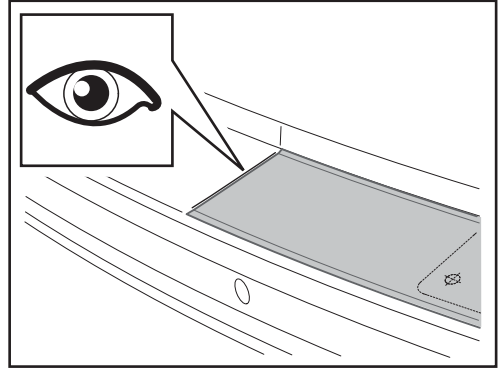
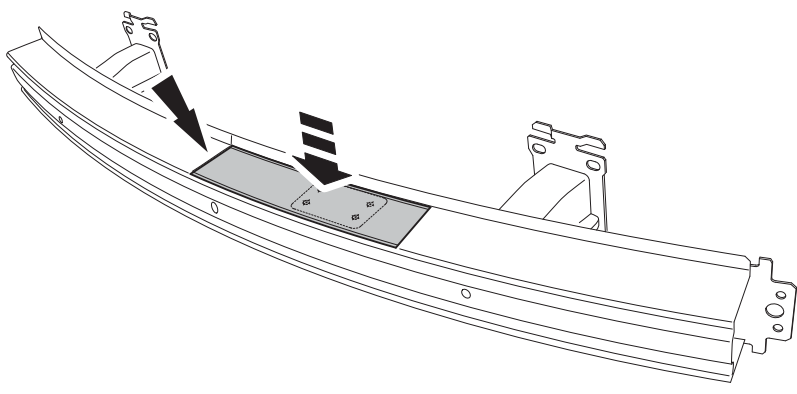

24

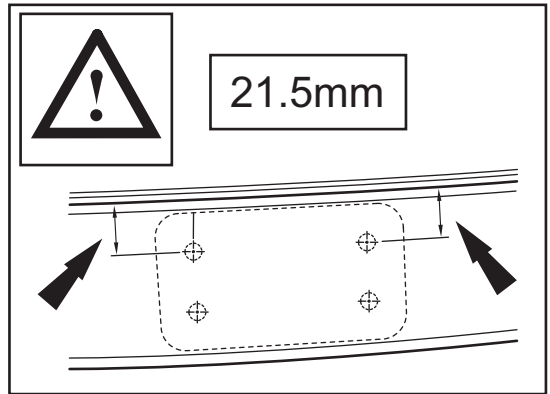
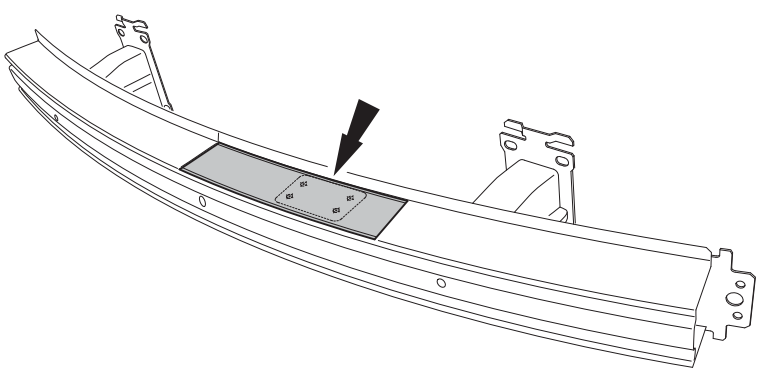

25

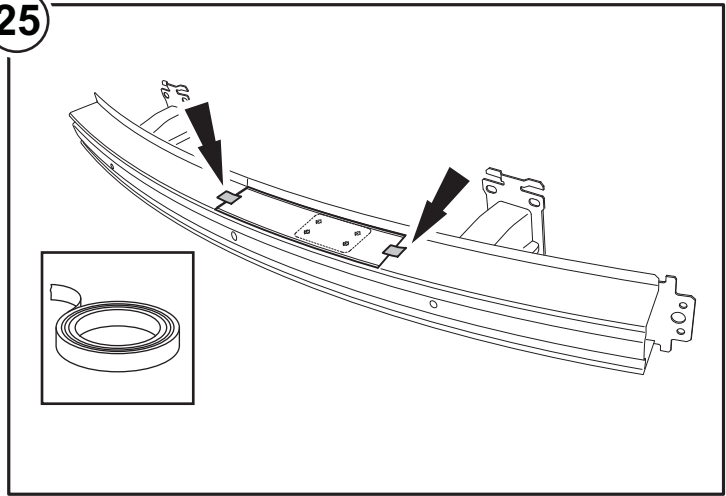

26

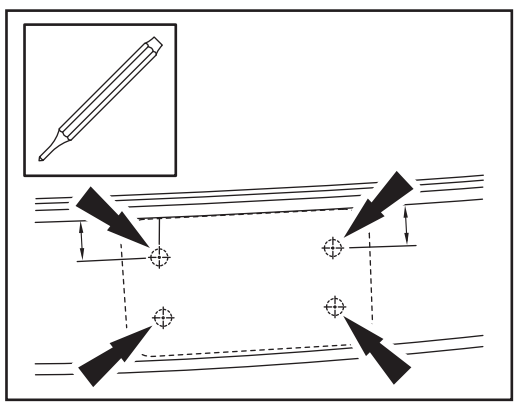
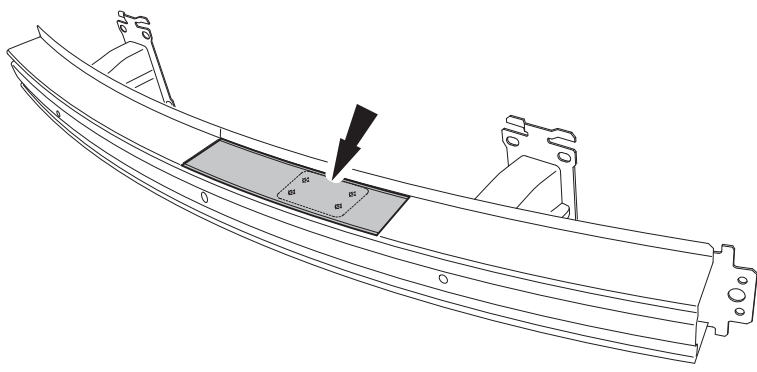

27

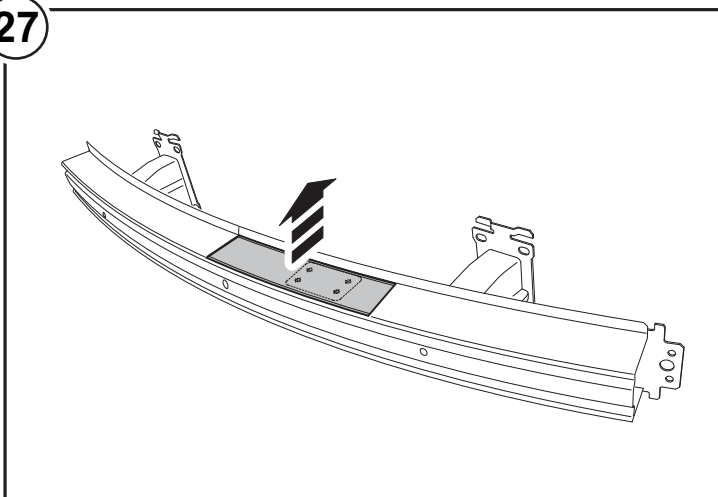

28

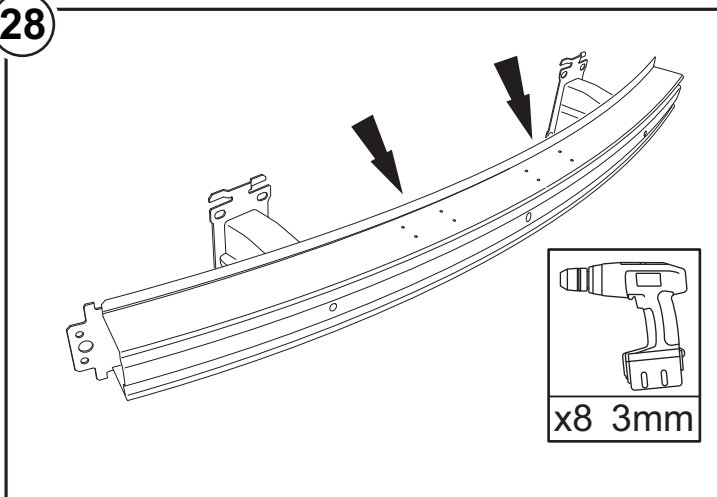

29

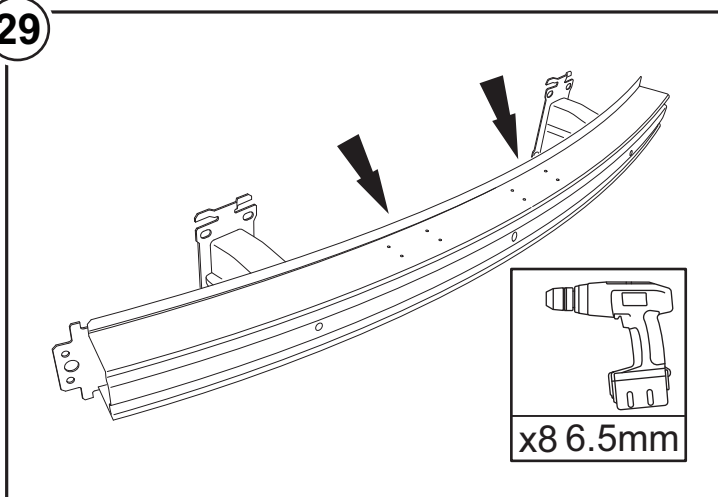

30

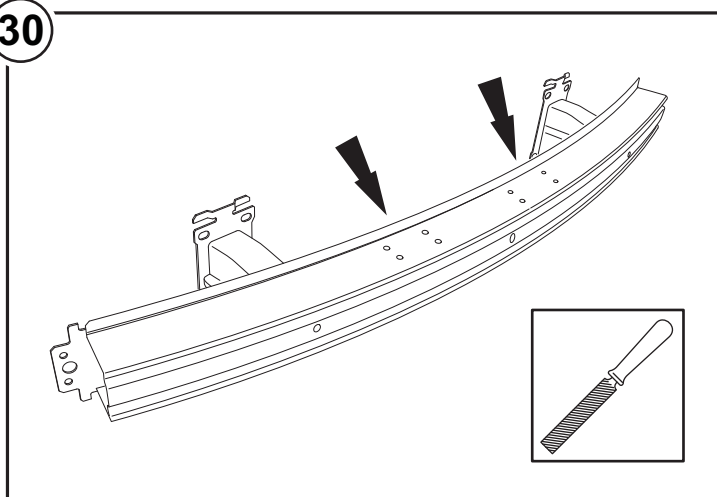

31

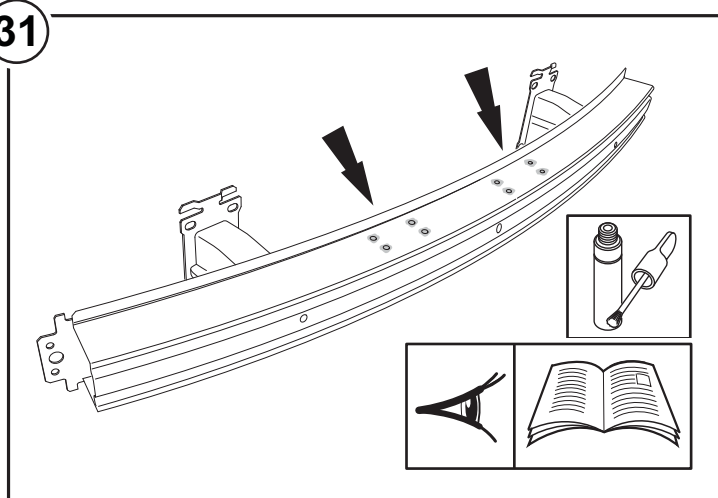

32

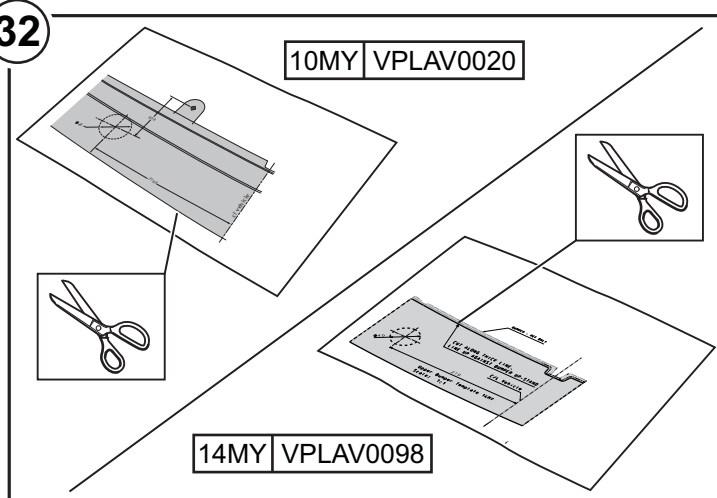

33

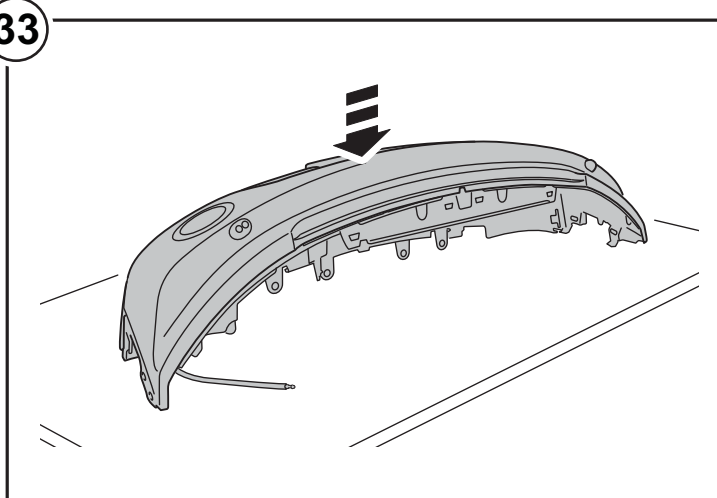

34

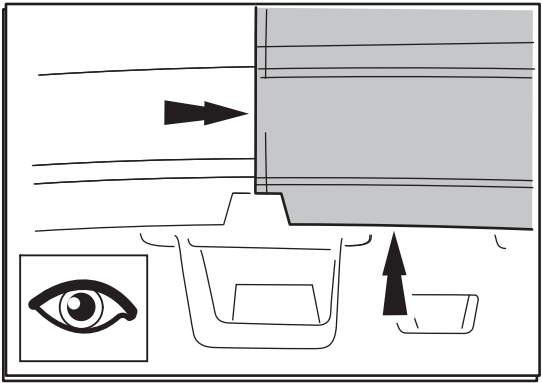
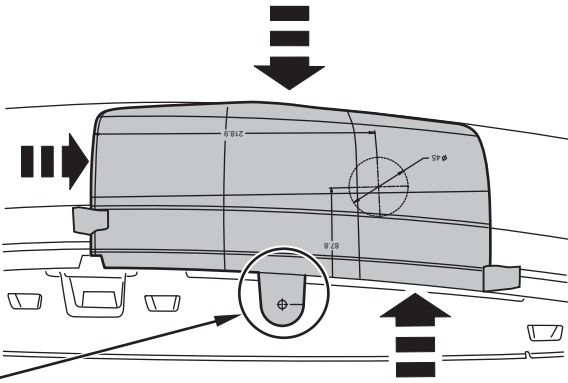
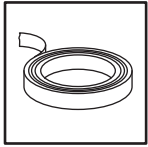

35

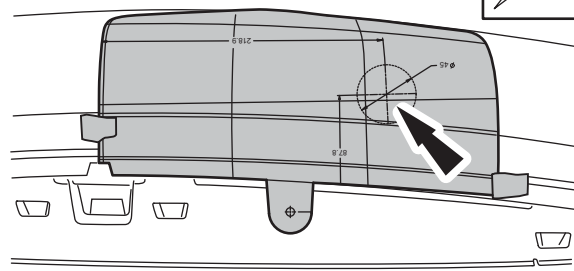
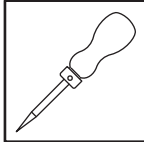

36

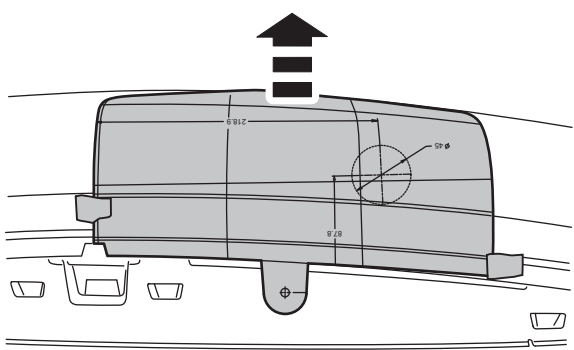

37

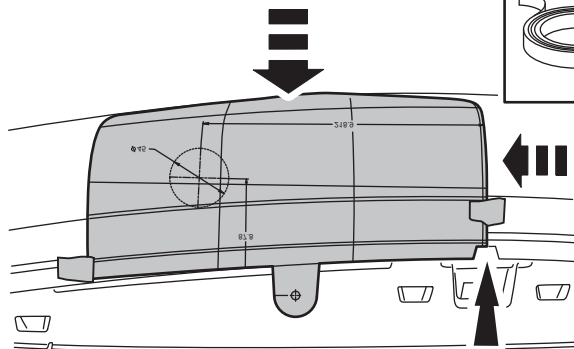

38

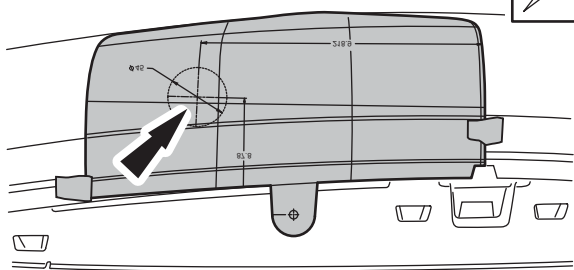
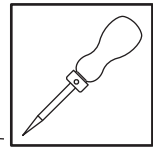

39

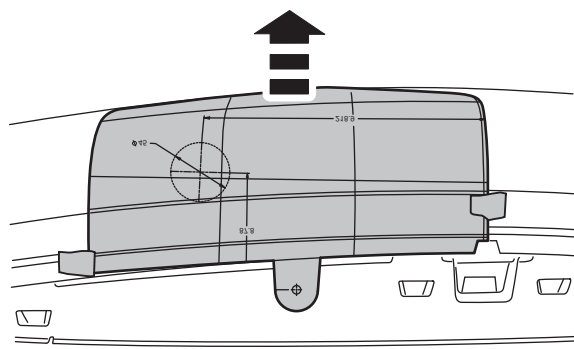

40

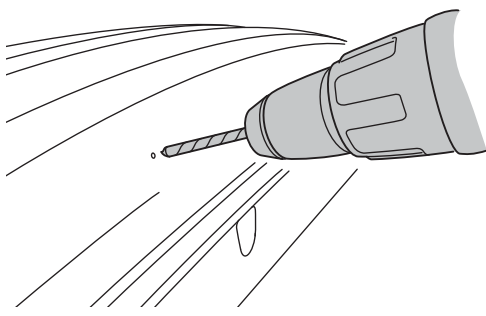
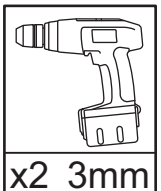

41

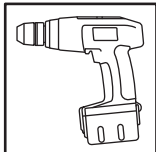
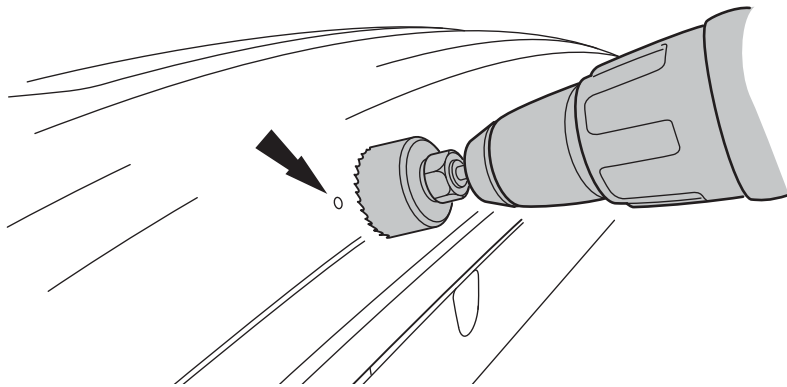

x2 38mm

10MY - VPLAV0020

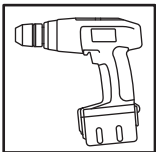

x2 40mm

14MY - VPLAV0098

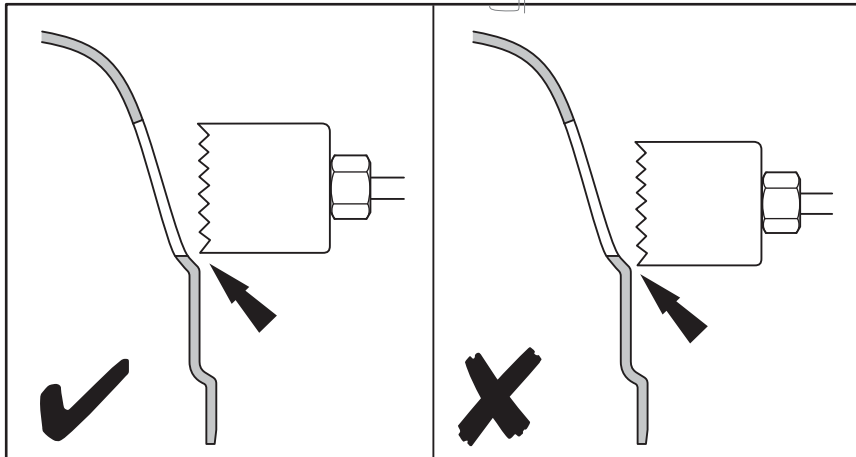

42

10MY - VPLAV0020

14MY - VPLAV0098

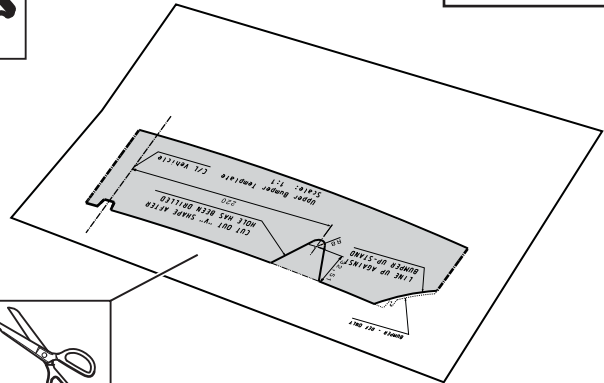
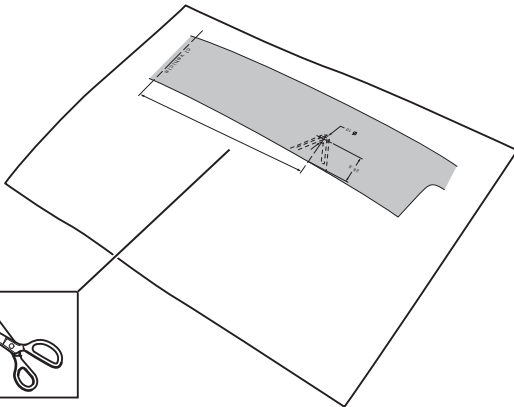

43

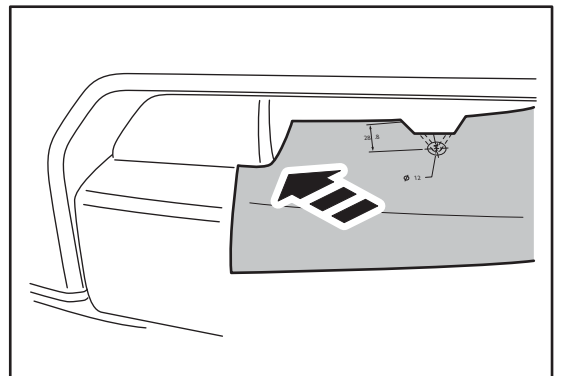
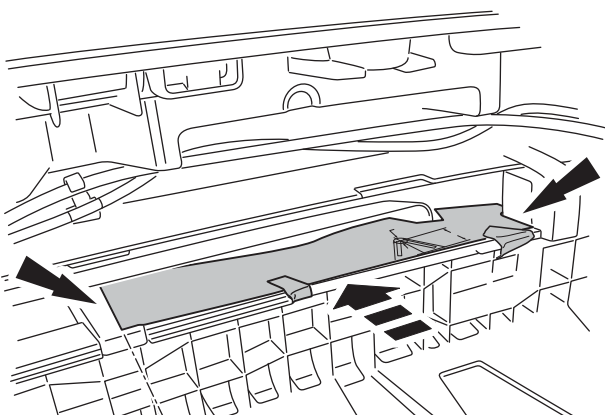
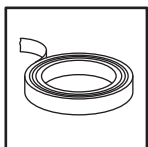

44

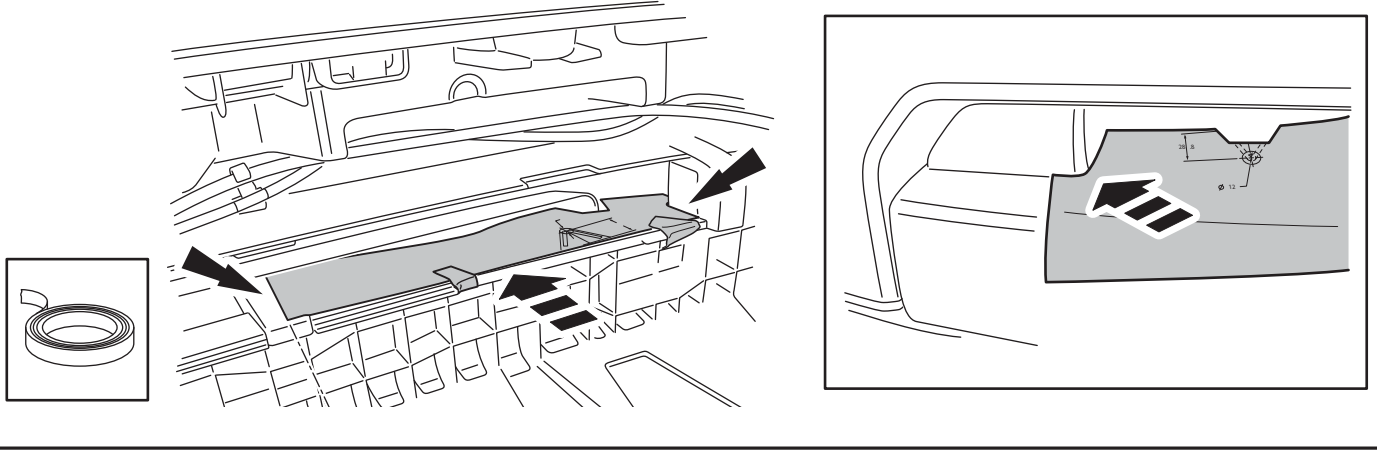

45

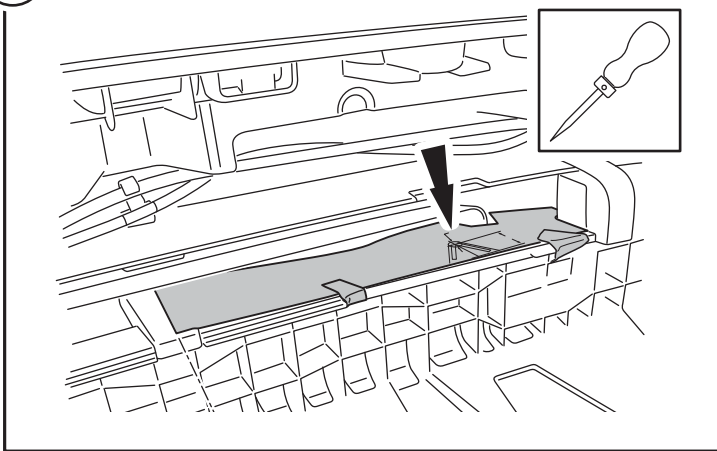

46

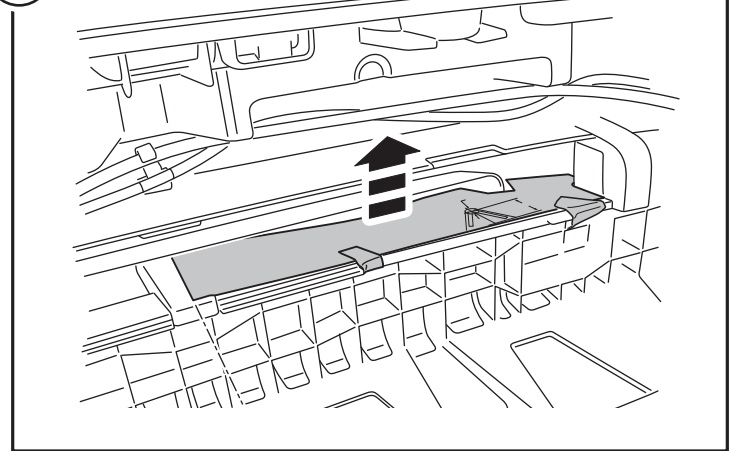

47

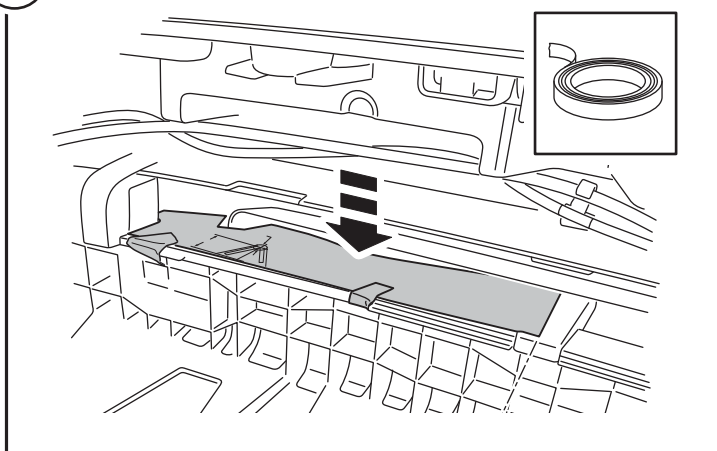

48

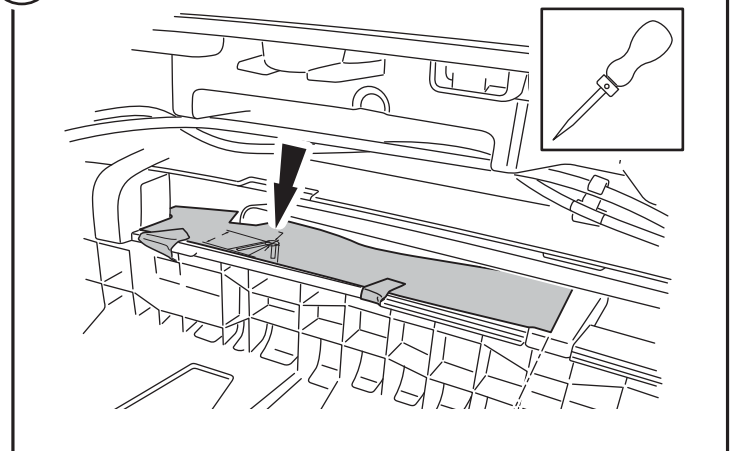

49

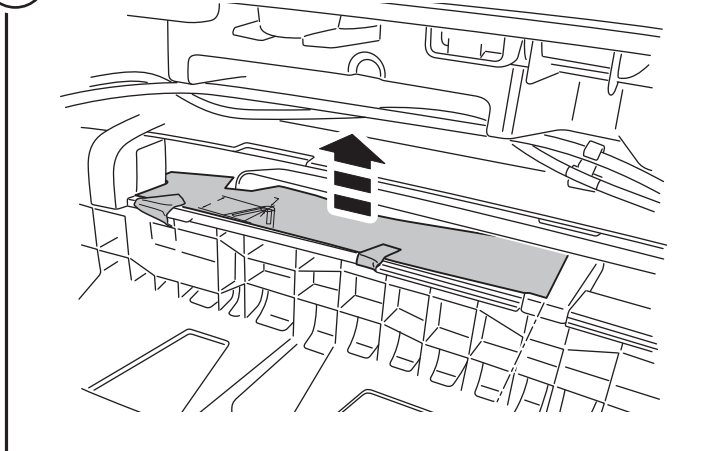

50

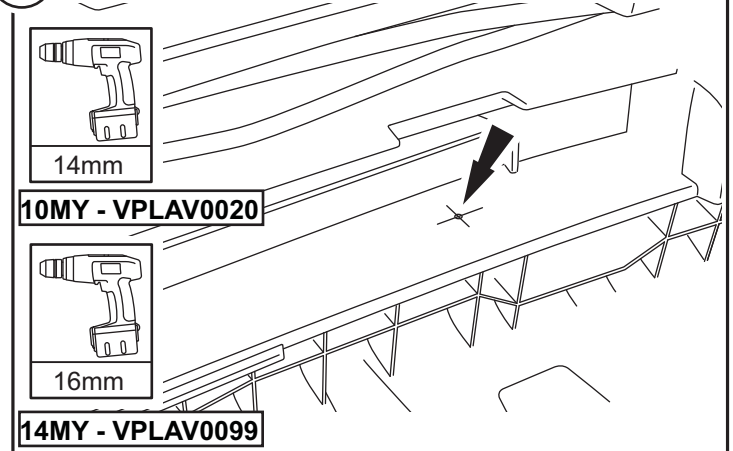

51



14mm

10MY - VPLAV0020



16mm

14MY - VPLAV0098

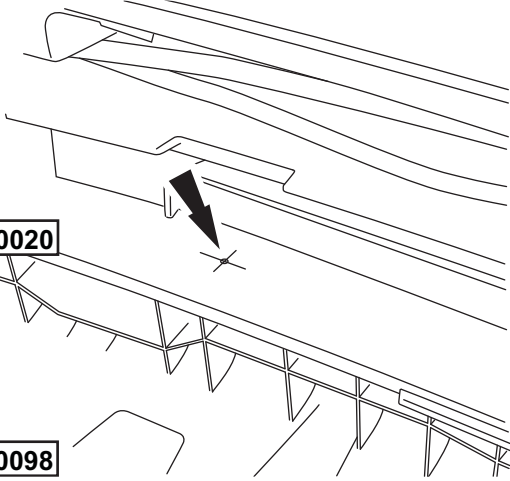

52

10MY - VPLAV0020

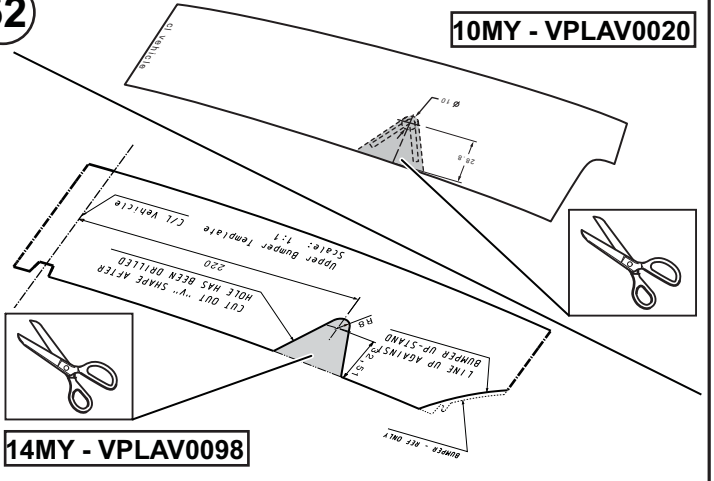

14MY - VPLAV0098

53

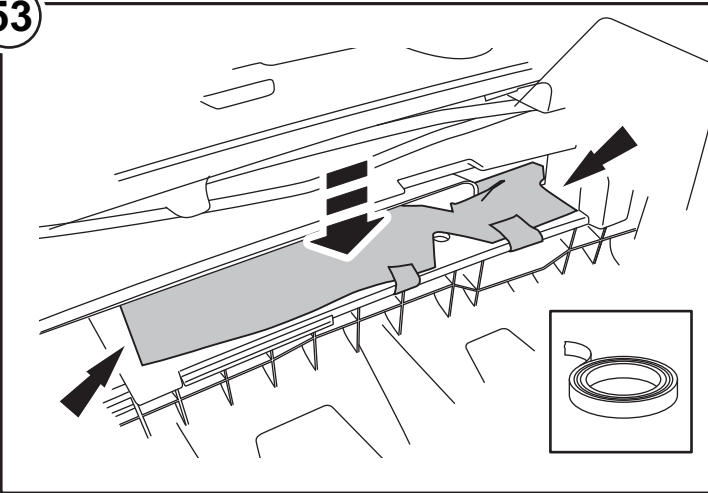

54

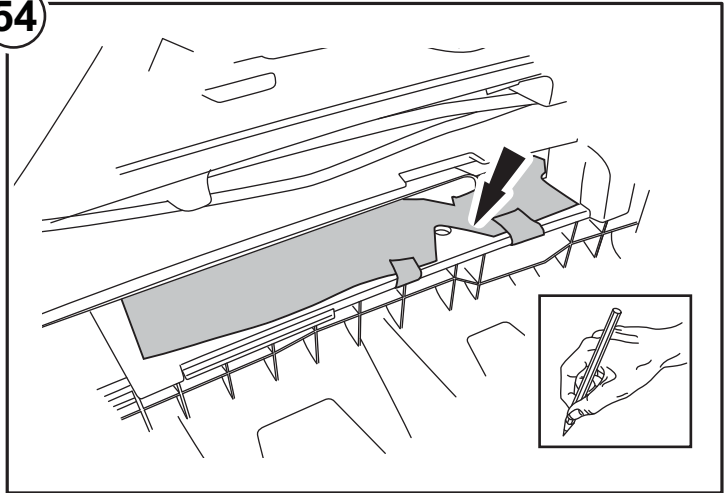

55

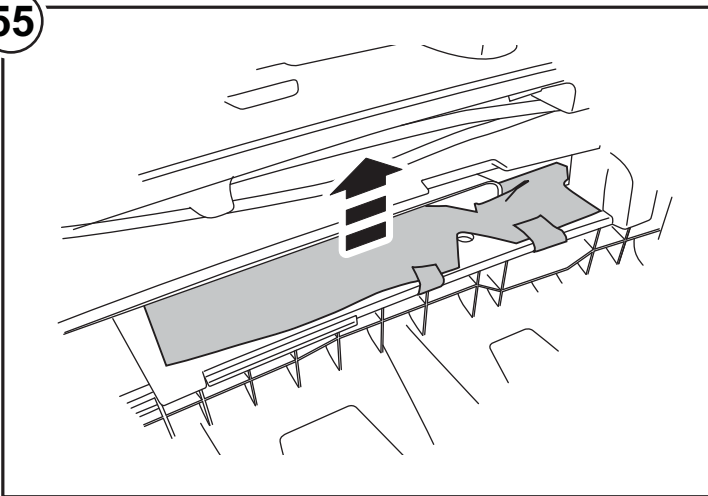

56

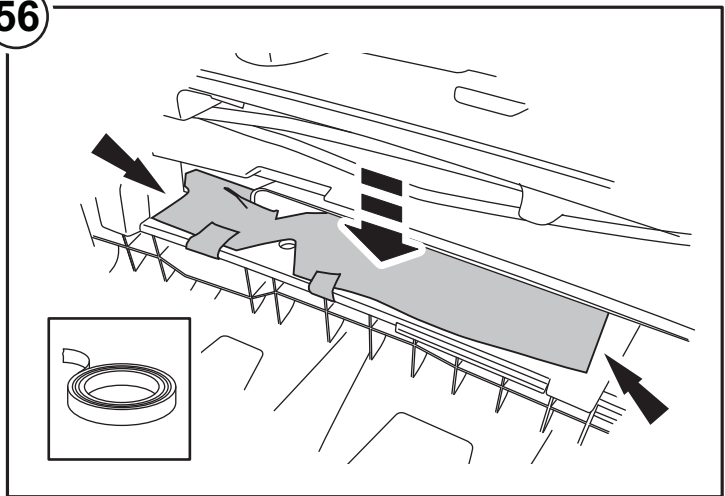

57

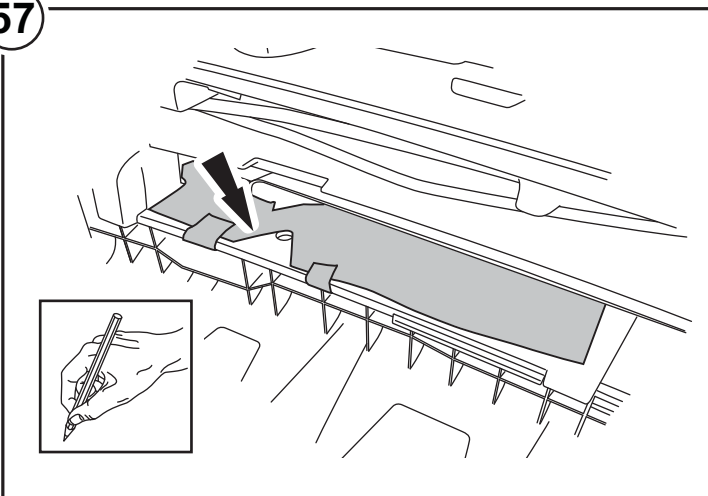

58

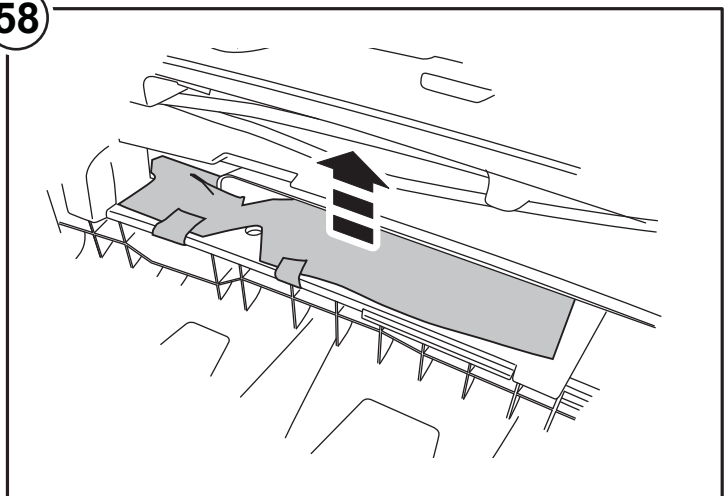

59

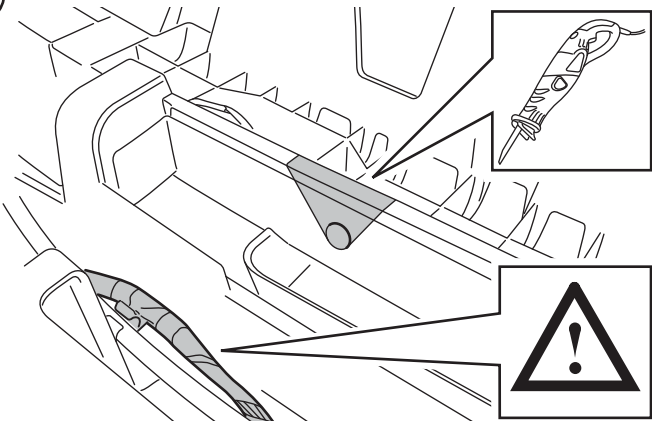

60

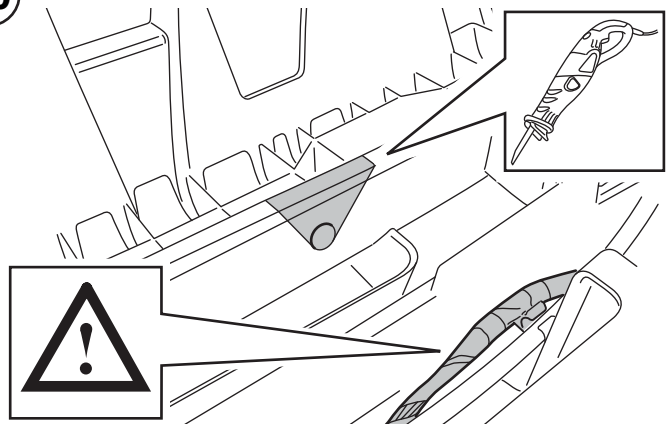

61

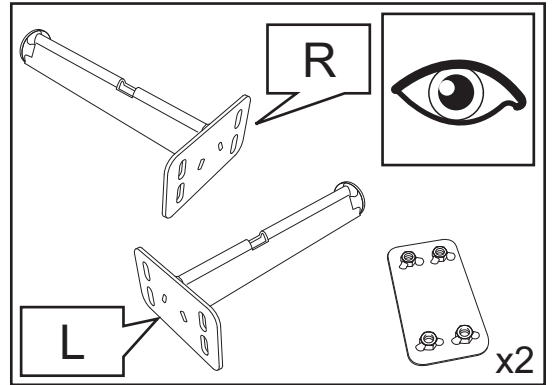
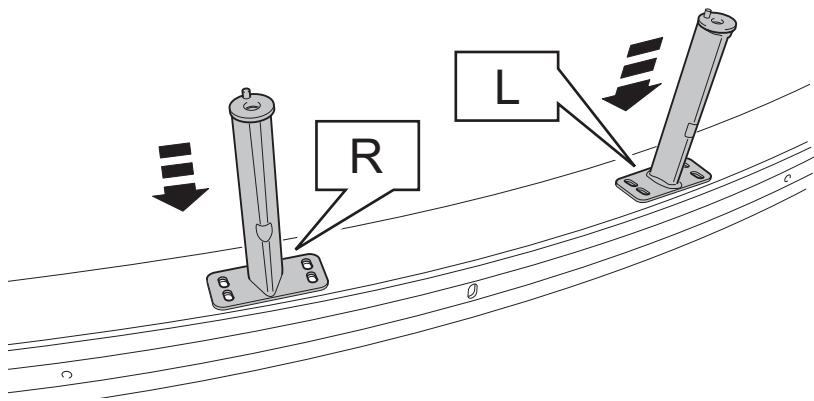

62

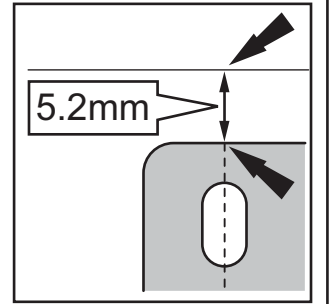
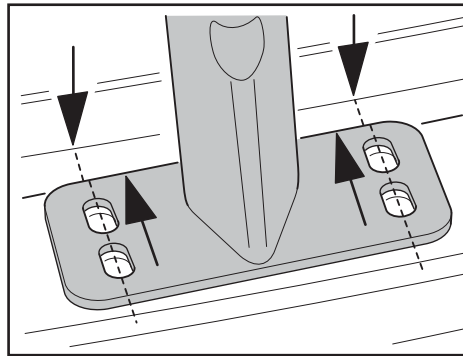
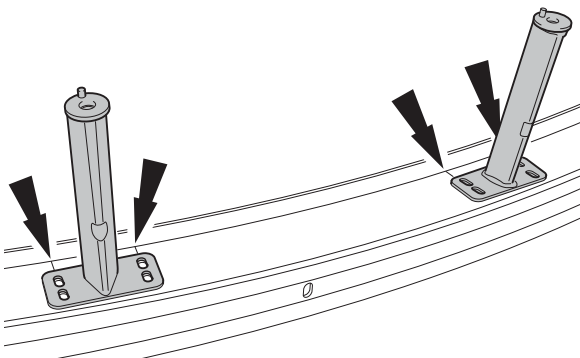

63

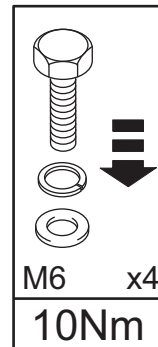
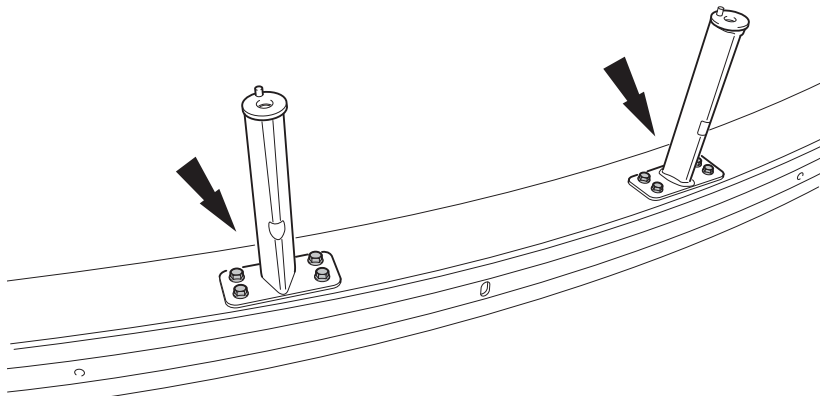
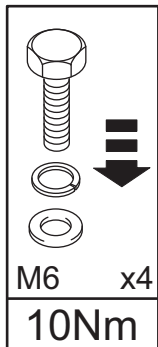

64

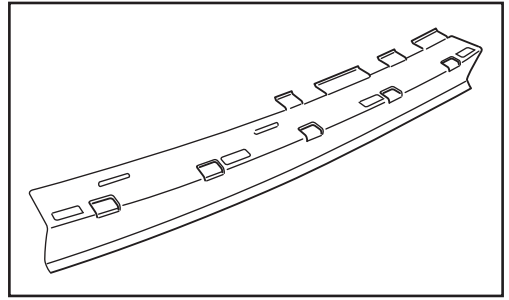
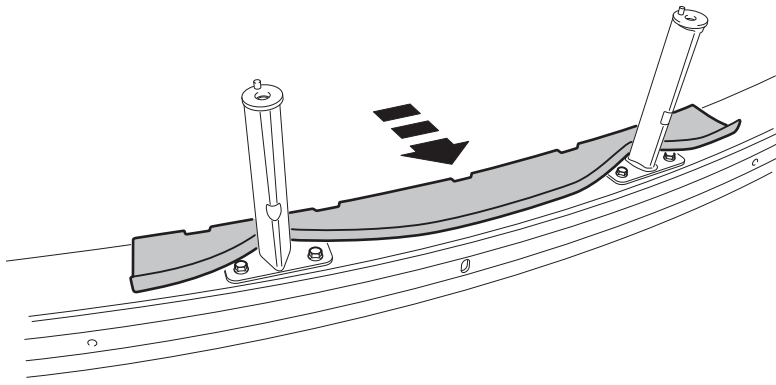

65

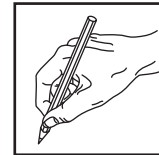
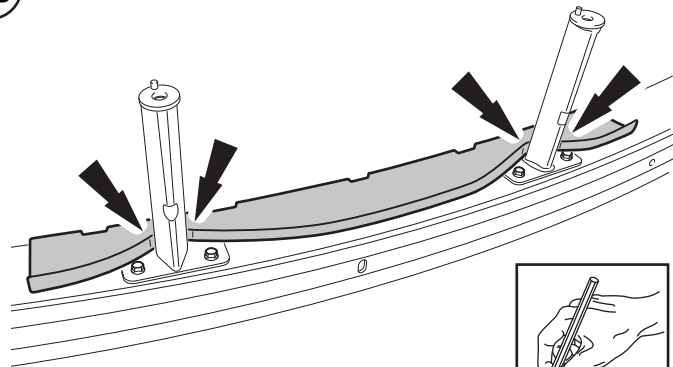

66

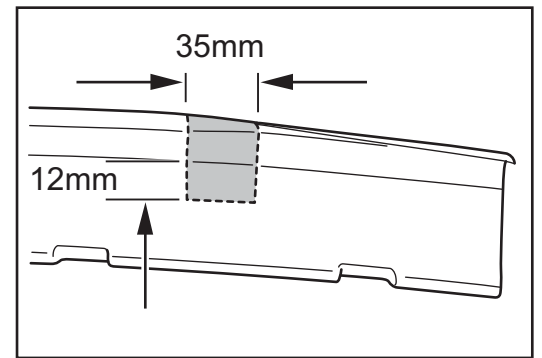
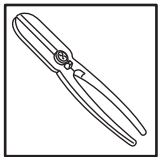
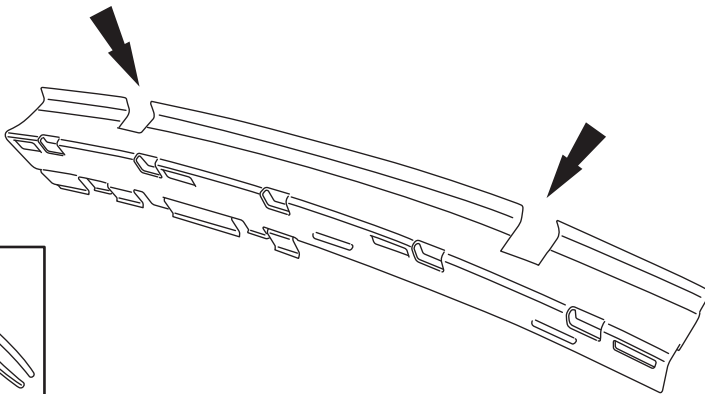

67

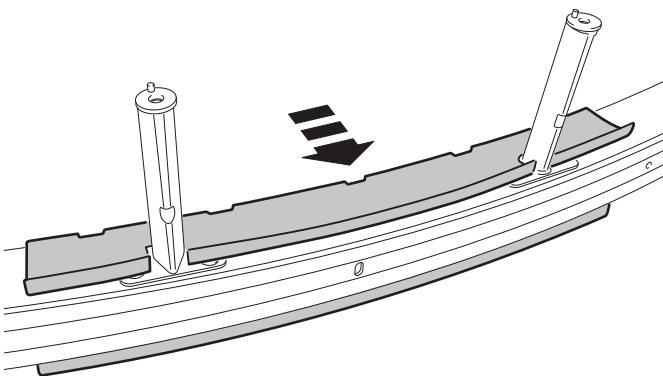

68

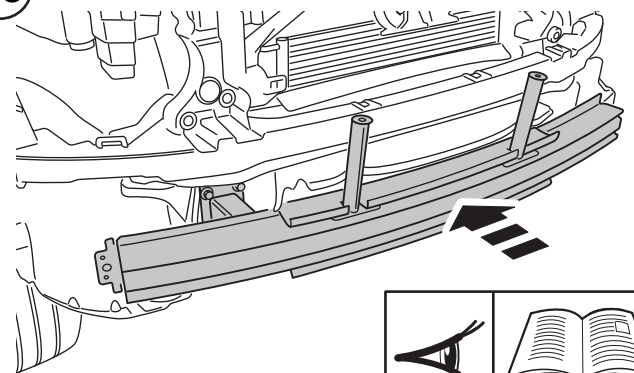

69

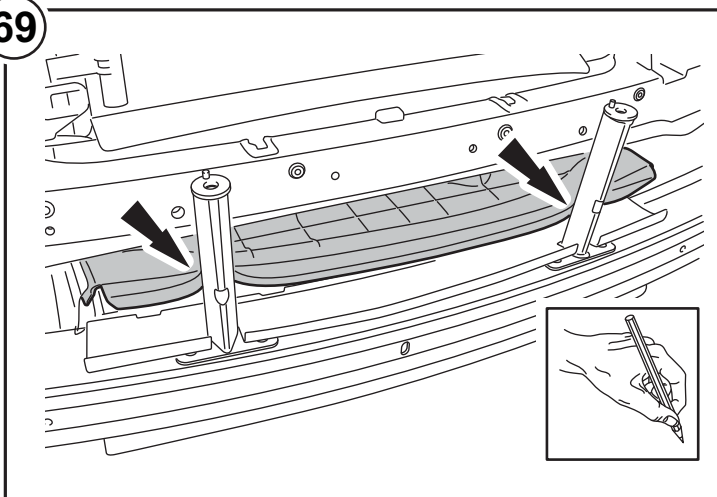

70

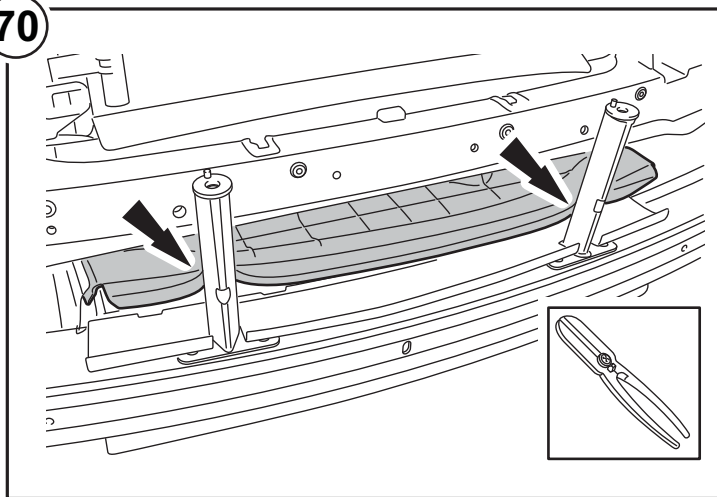

71

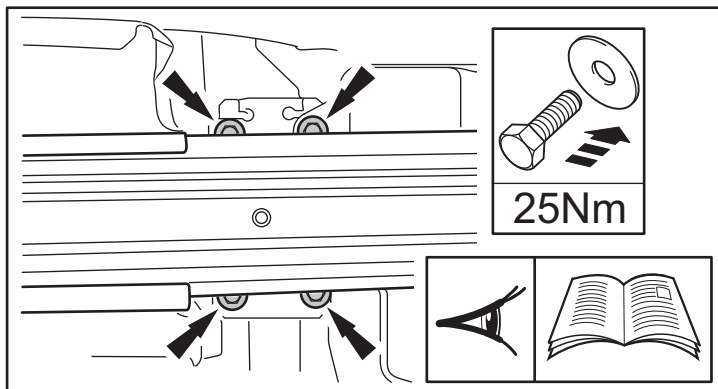
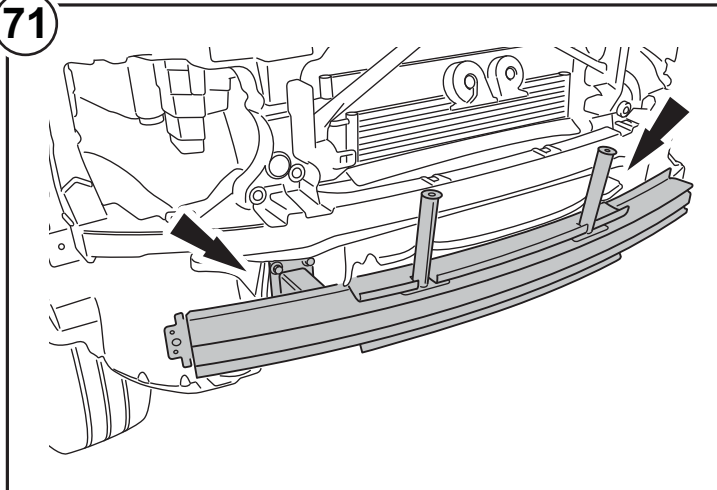

72

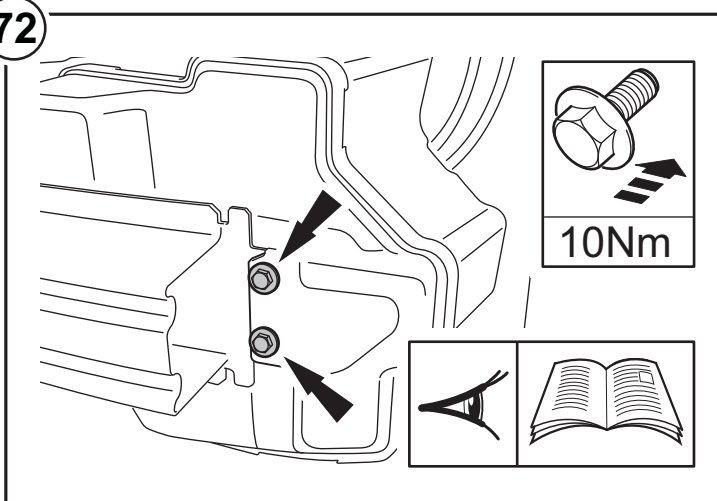

73

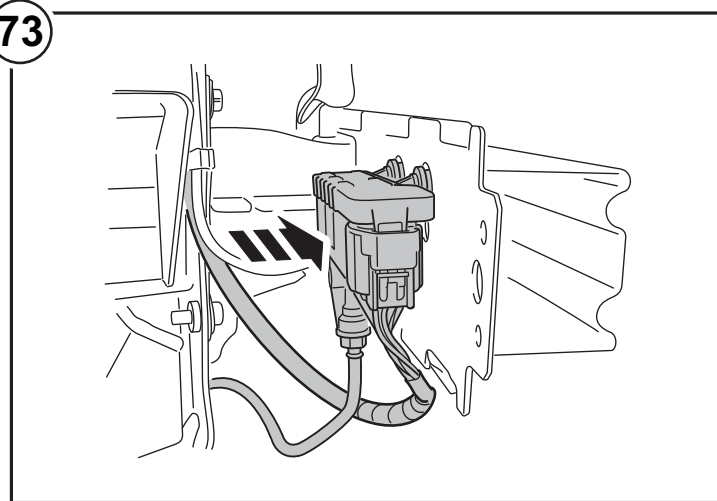

74

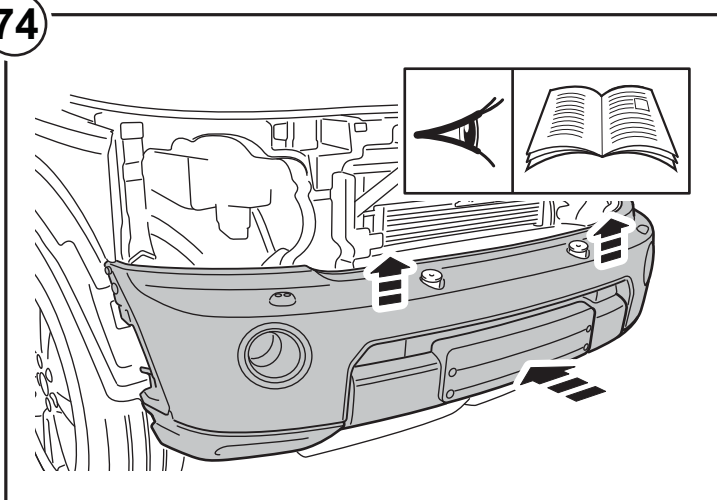

75

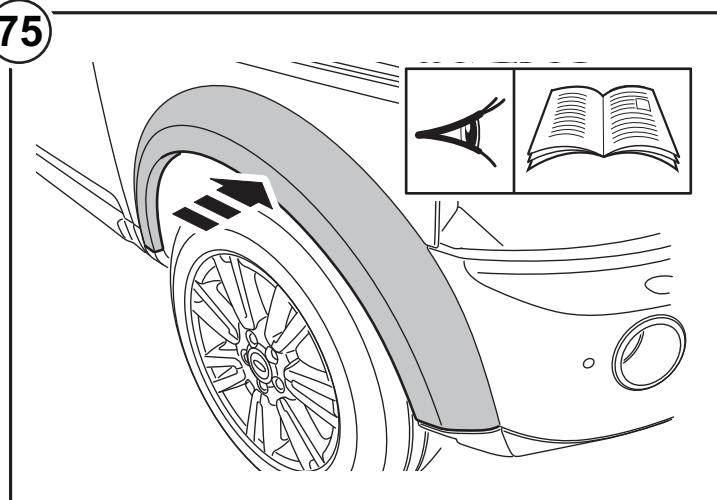

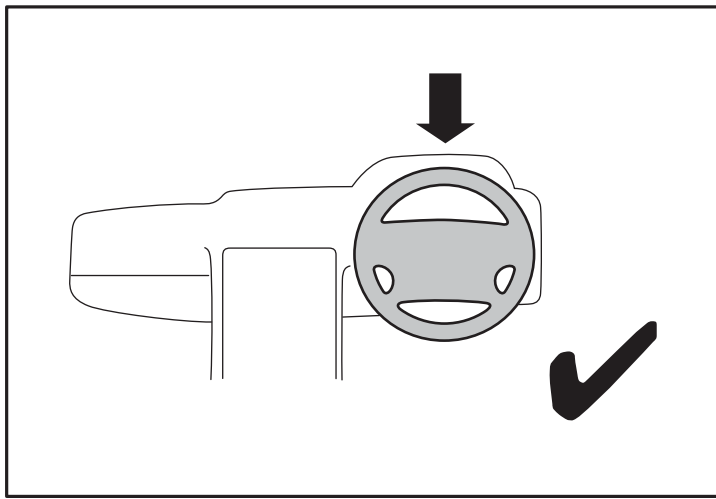

76

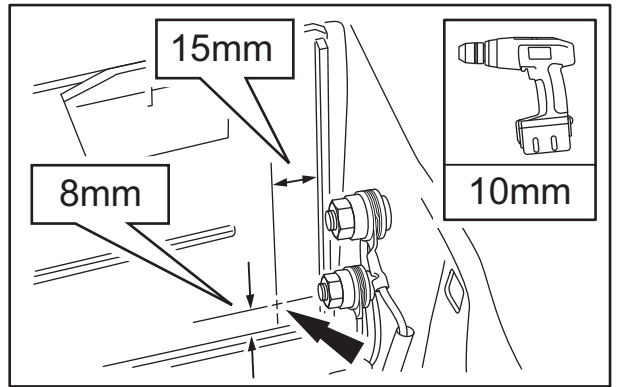
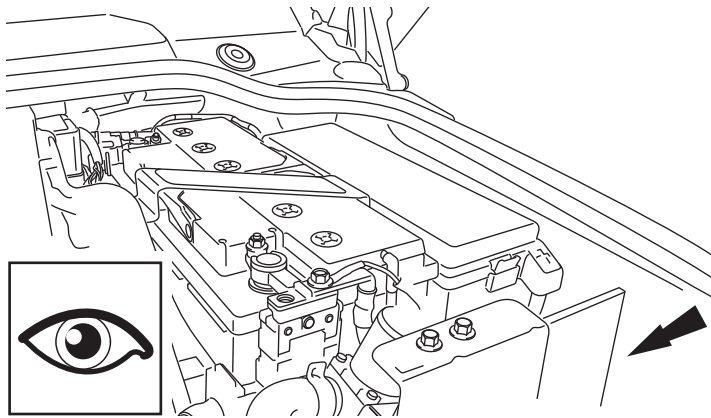

77

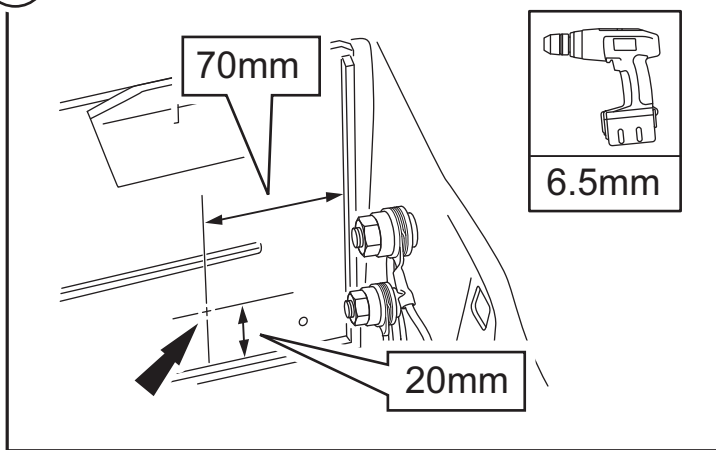

78

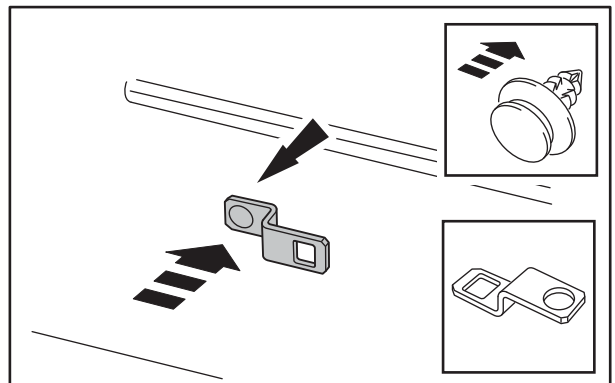
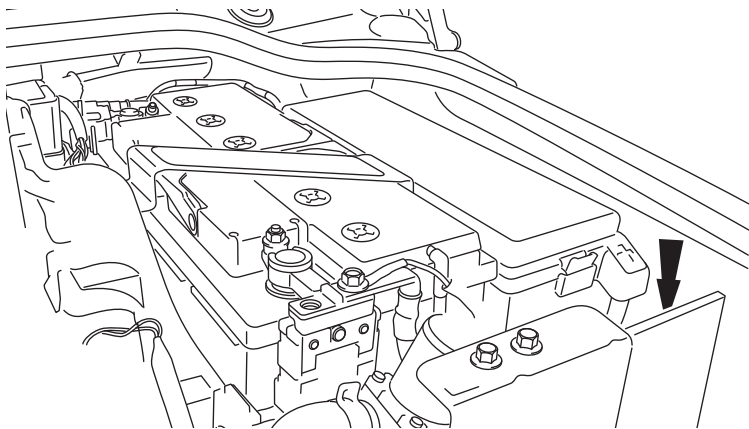

79

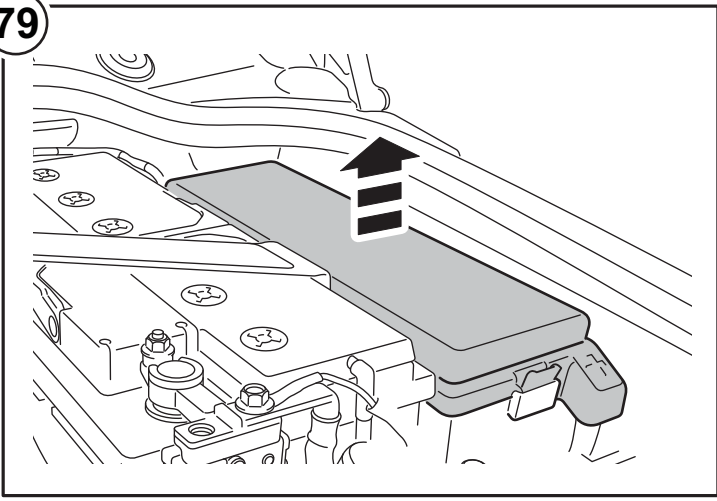

80

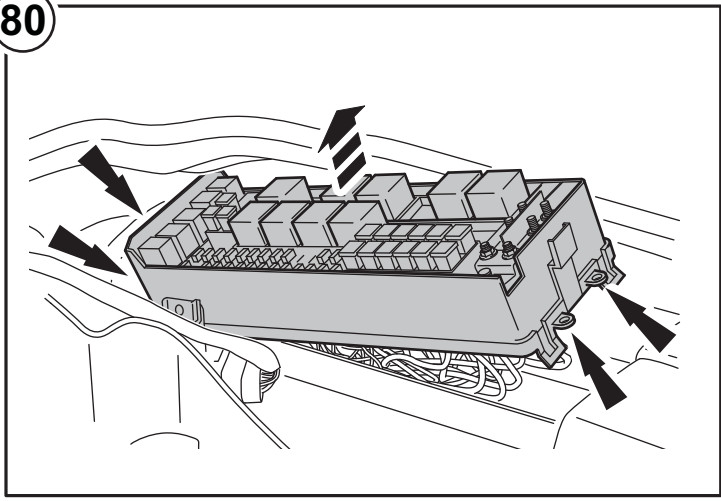

81

- (GB) Grey
- (D) Grau
- (F) Gris
- (I) Grigio
- (E) Gris
- (P) Cinzento
- (NL) Grijs
- (GR) Γκριζο
- (日) グレー
- (SU) Серый
- (国译) 灰色

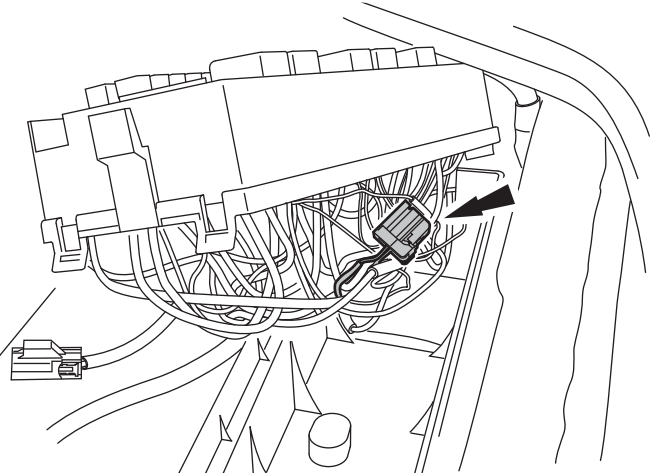

C3058



82

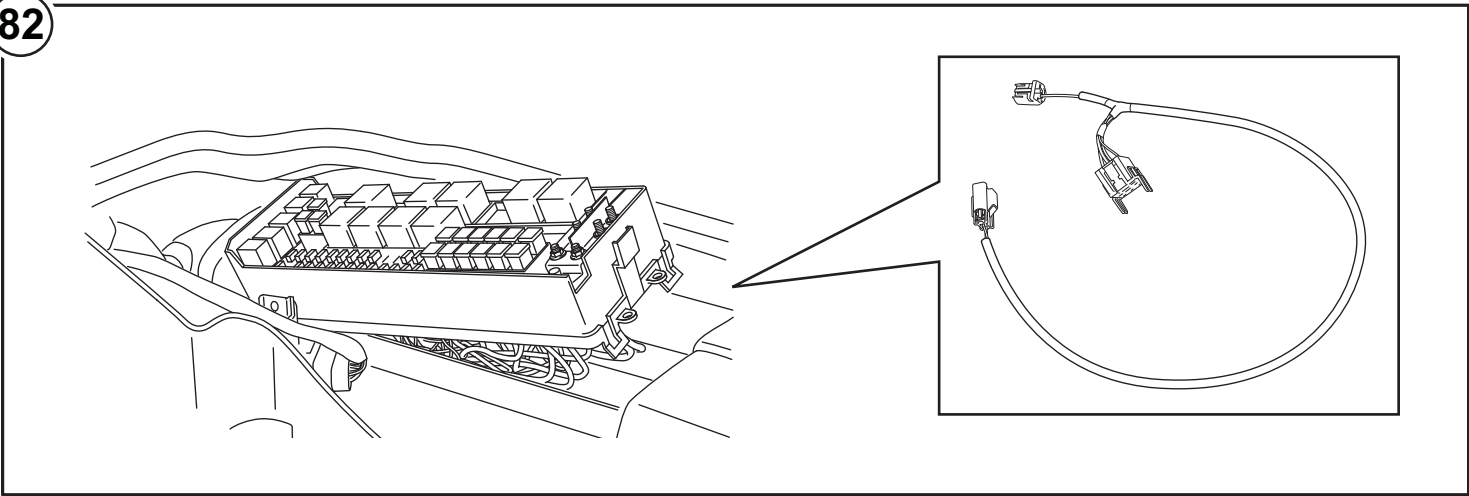

83

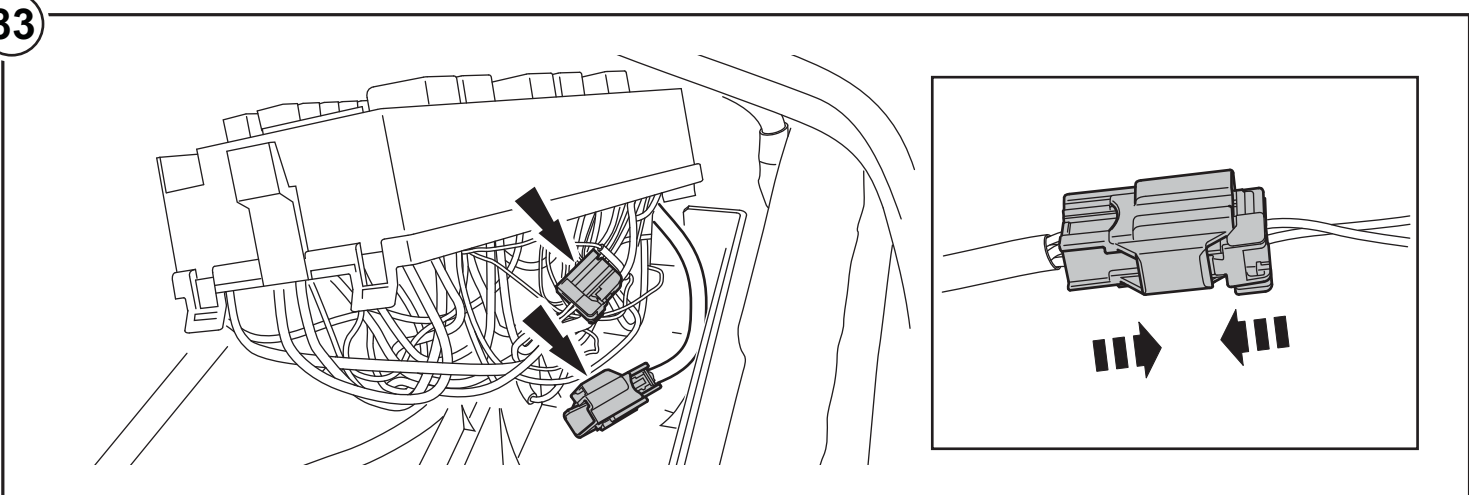

84

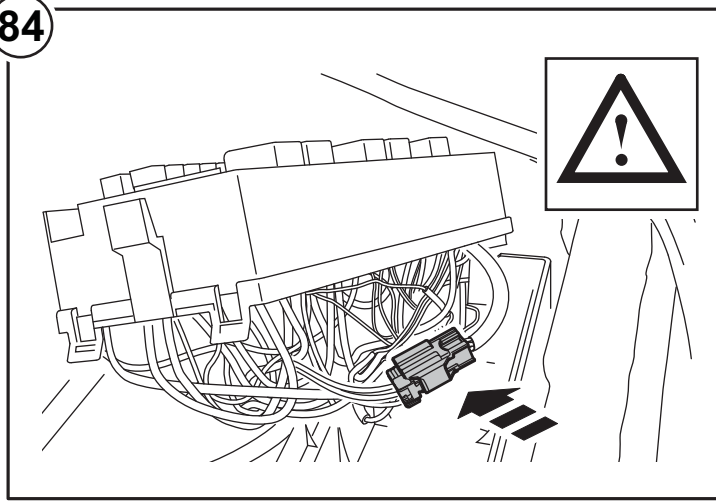

85

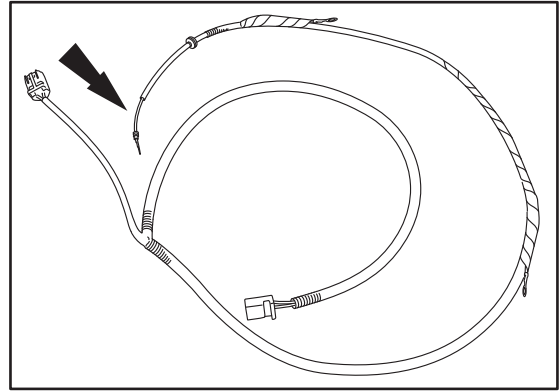
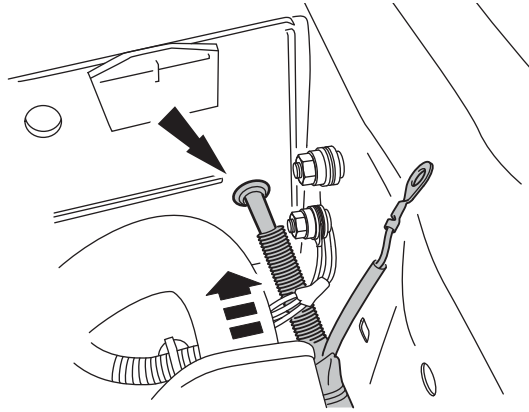

86

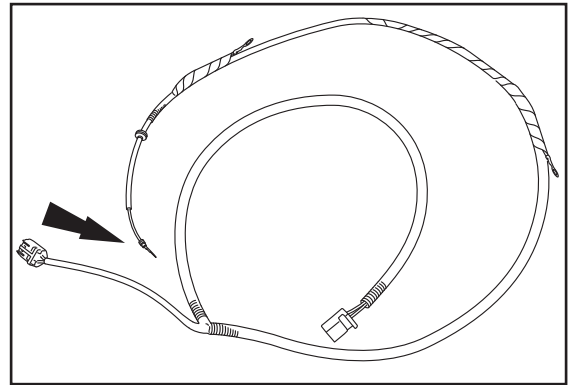
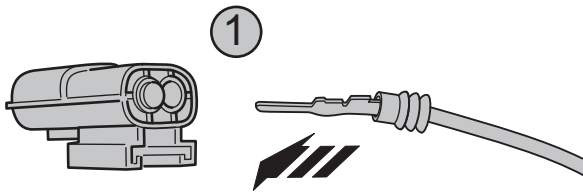
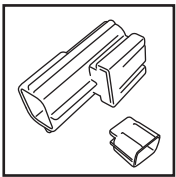

87

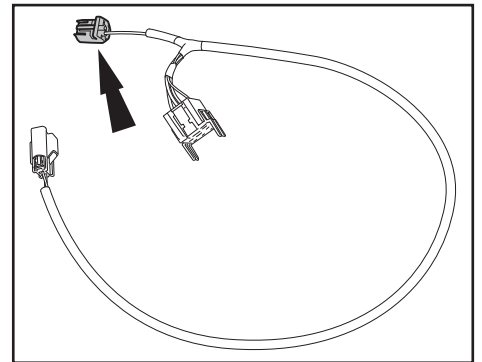
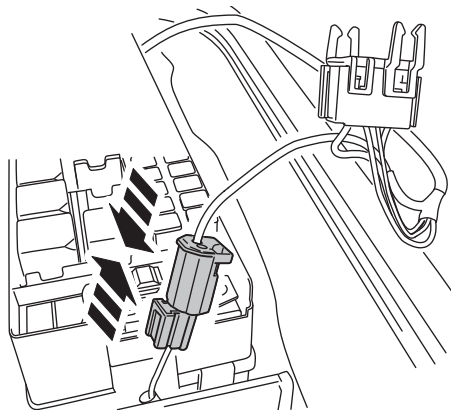
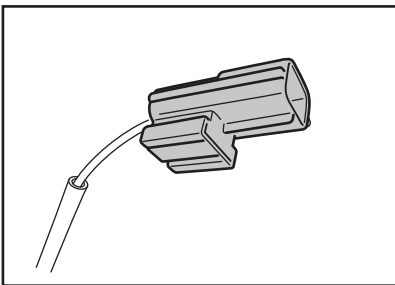

88

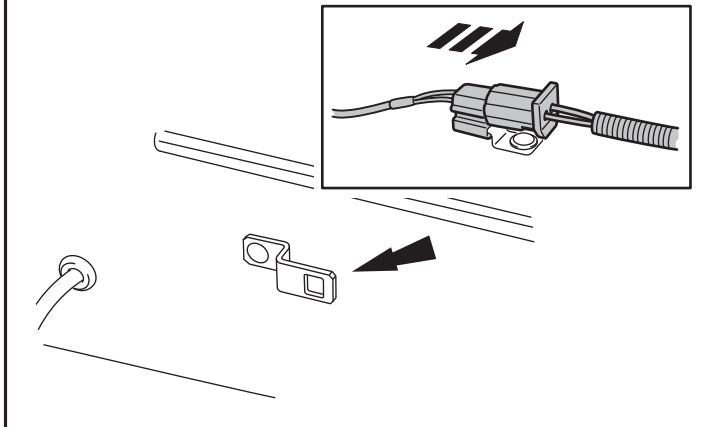

89

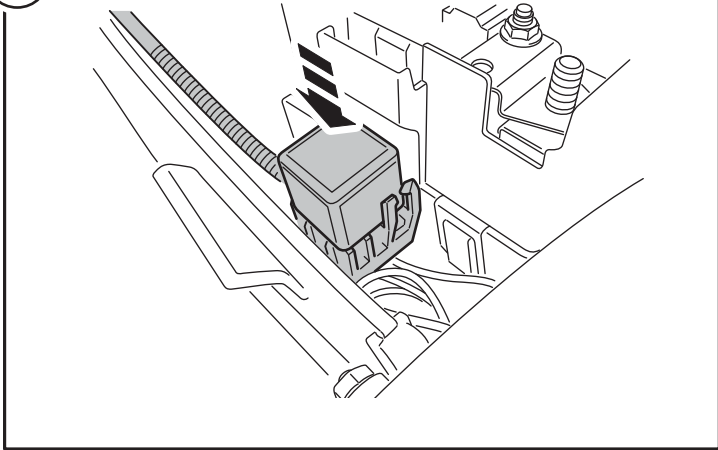

90

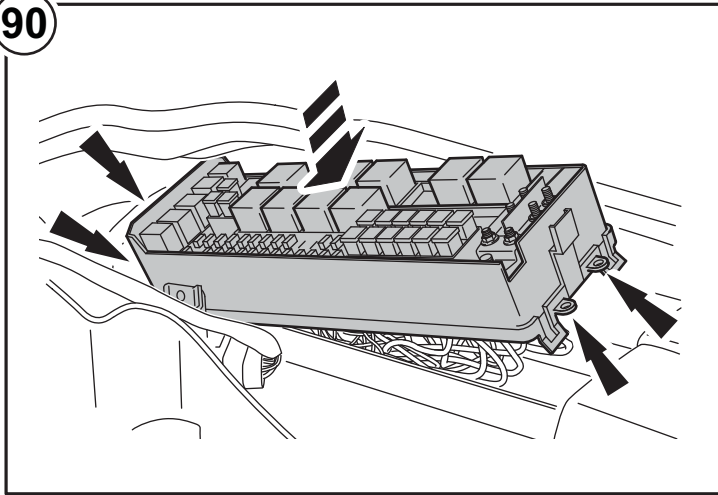

91

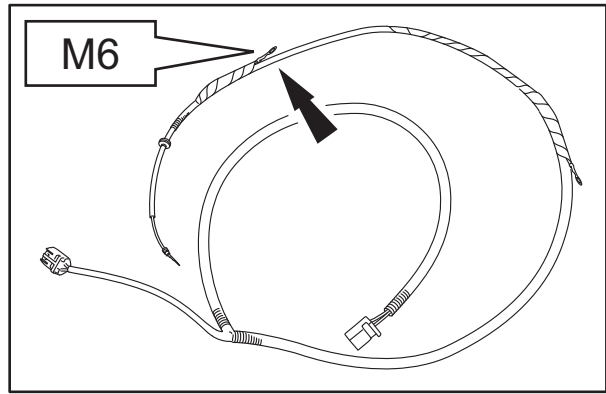
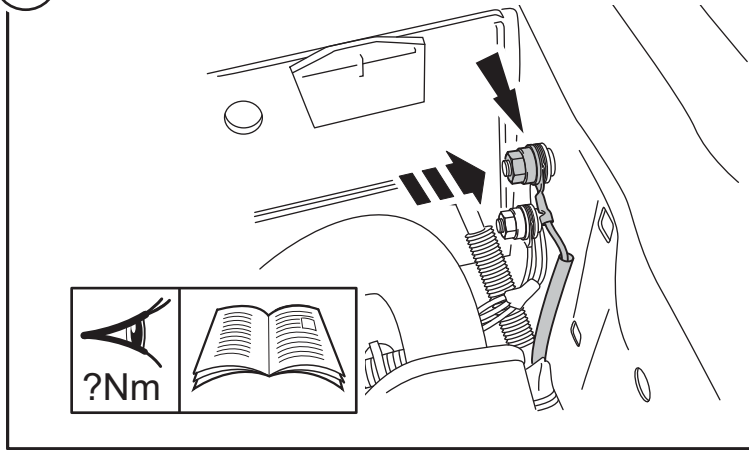

92

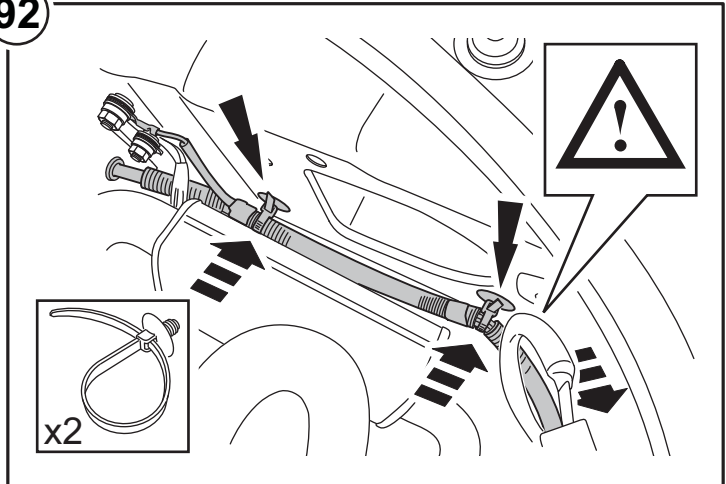

93

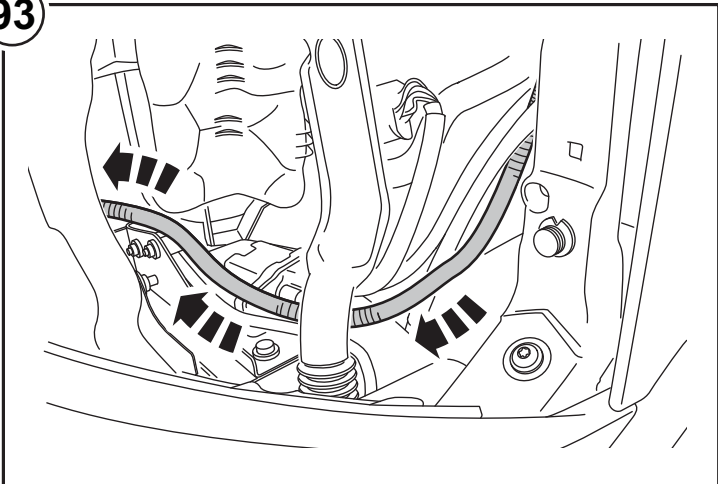

94

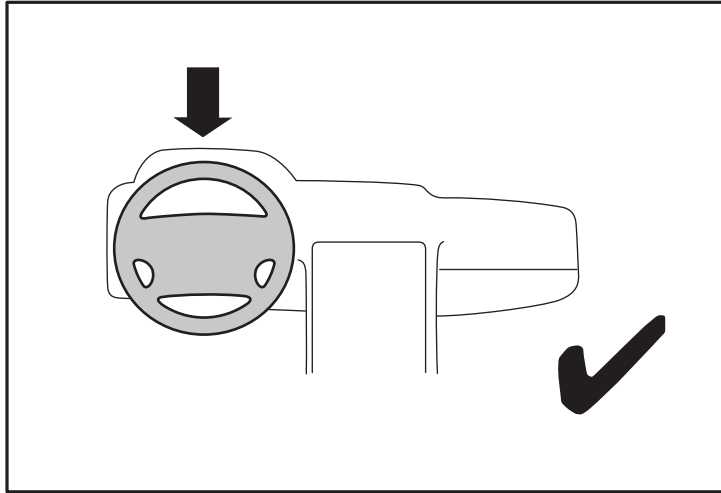
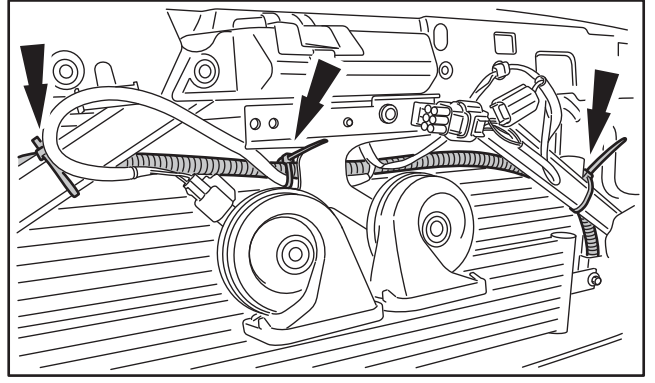
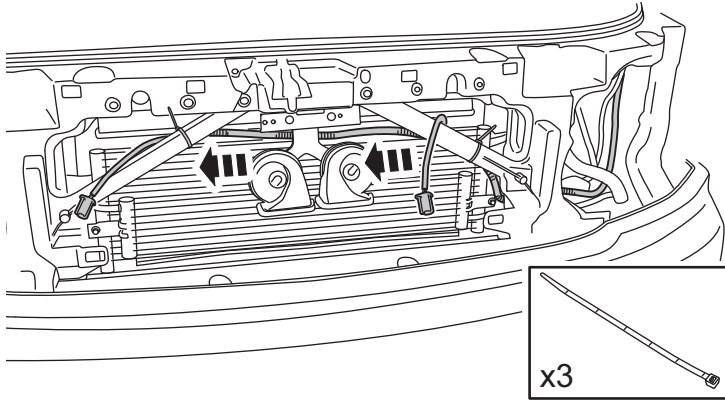

95

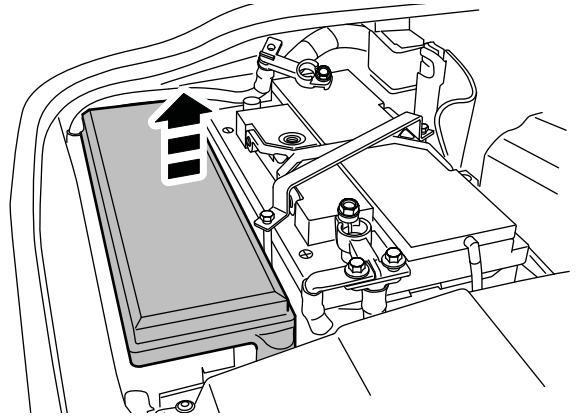

96

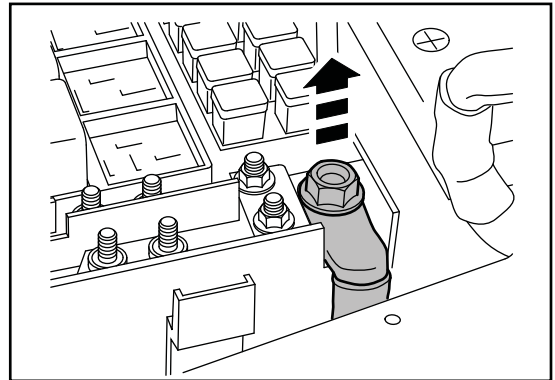
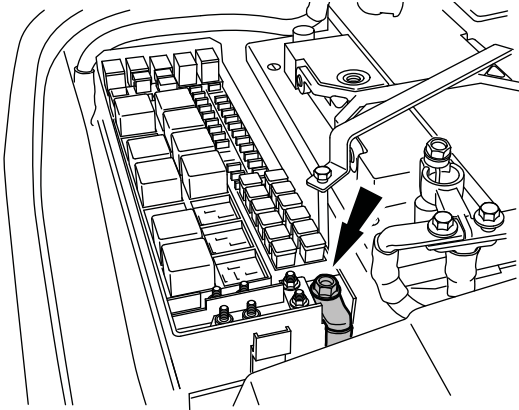

97

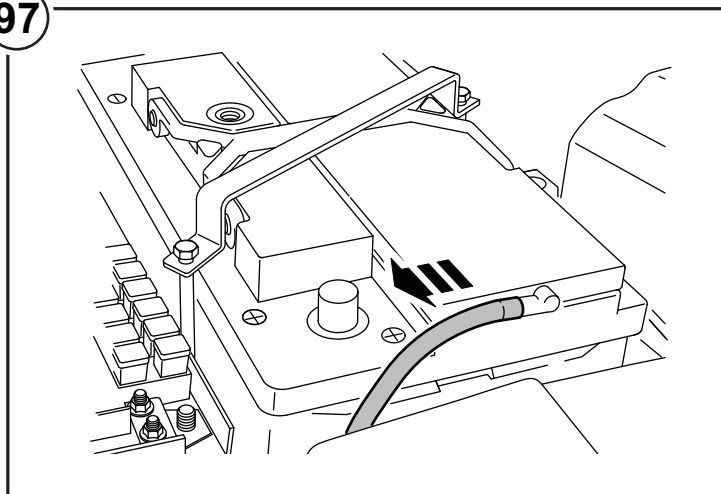

98

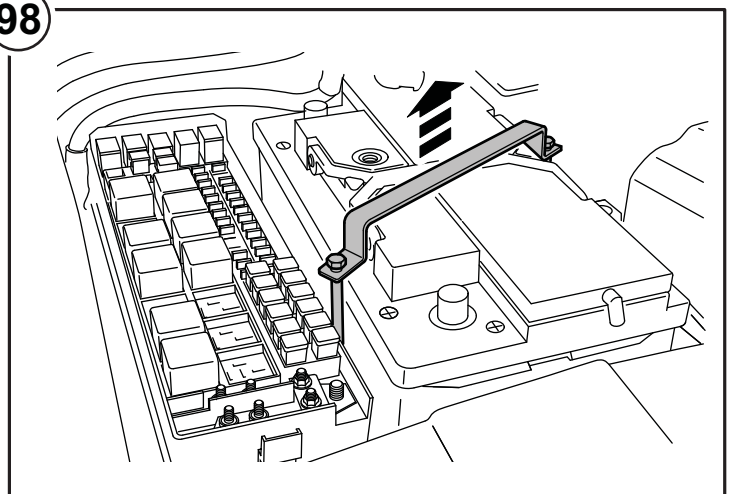

99

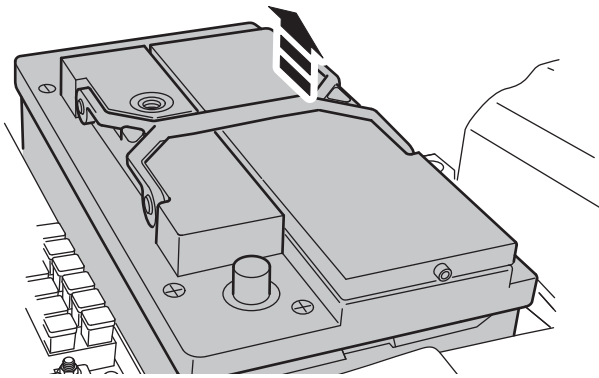

100

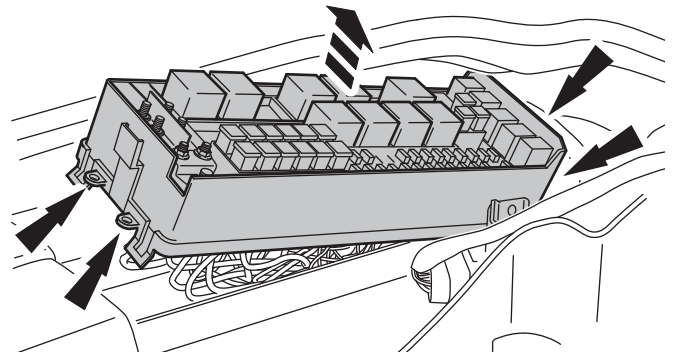

101

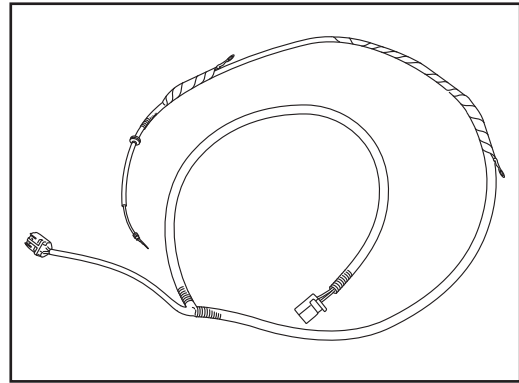
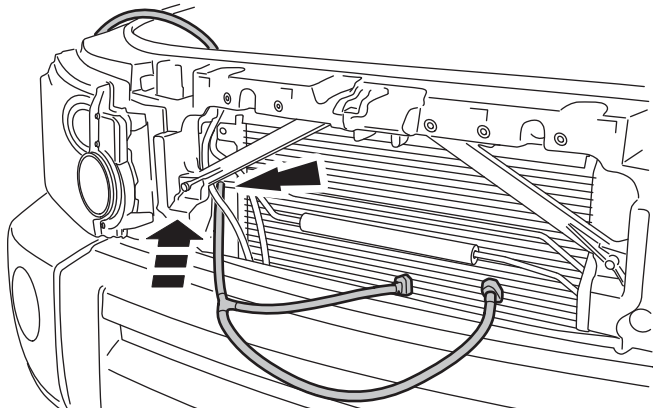

102

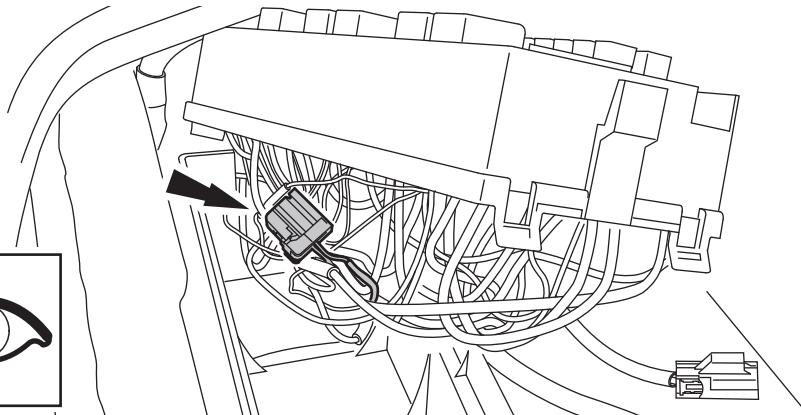

- (GB) Grey
- (D) Grau
- (F) Gris
- (I) Grigio
- (E) Gris
- (P) Cinzento
- (NL) Grijs
- (GR) Γκριζο
- (日) グレー
- (SU) Серый
- (国語) 灰色

103

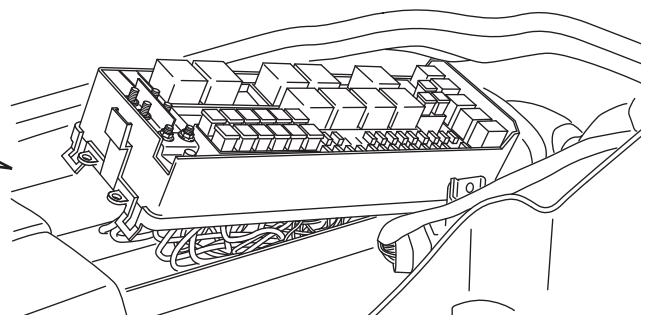
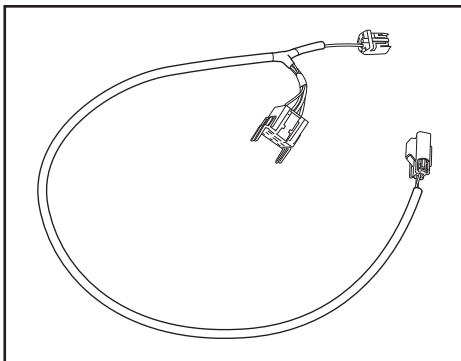

104

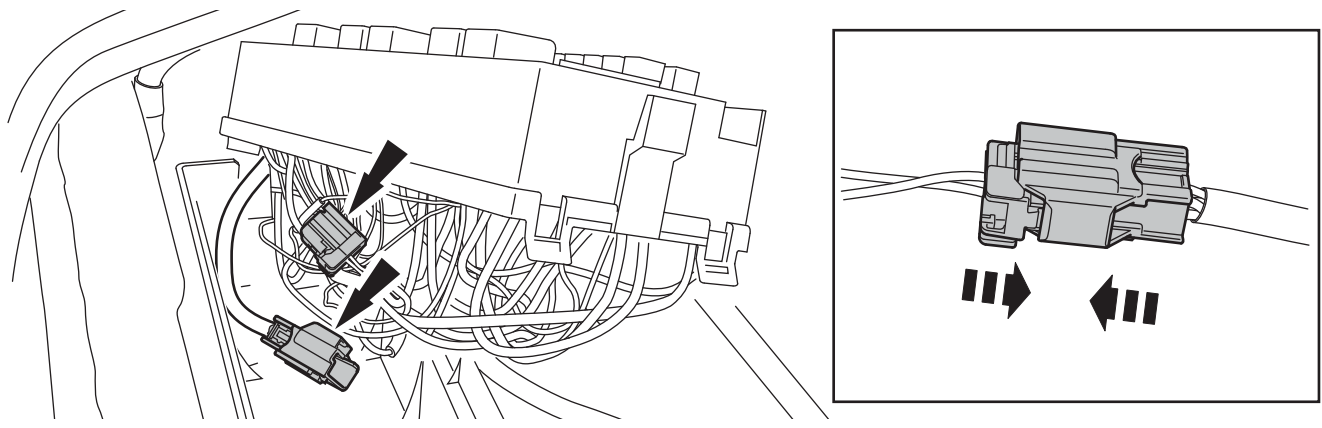

105

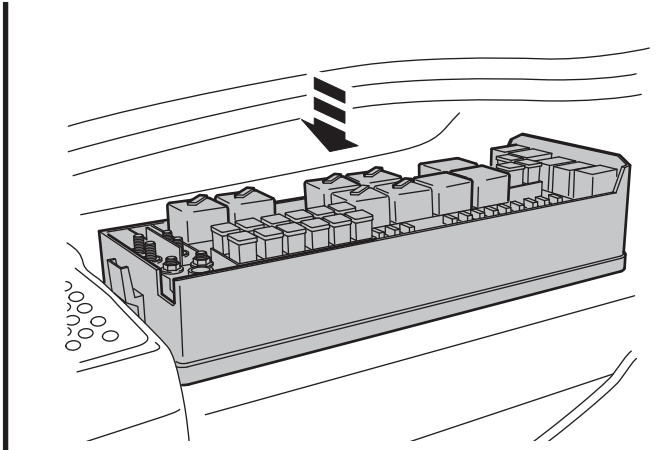
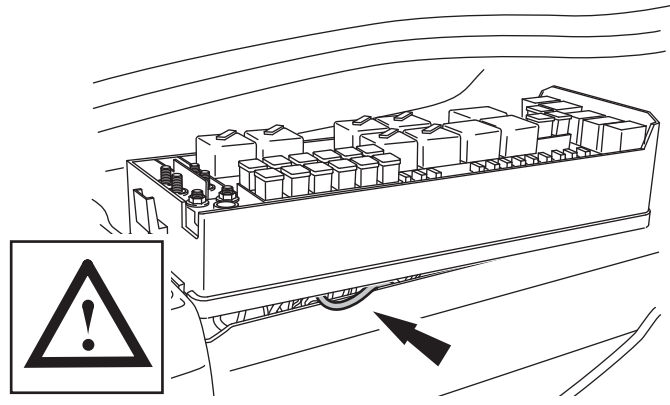

106

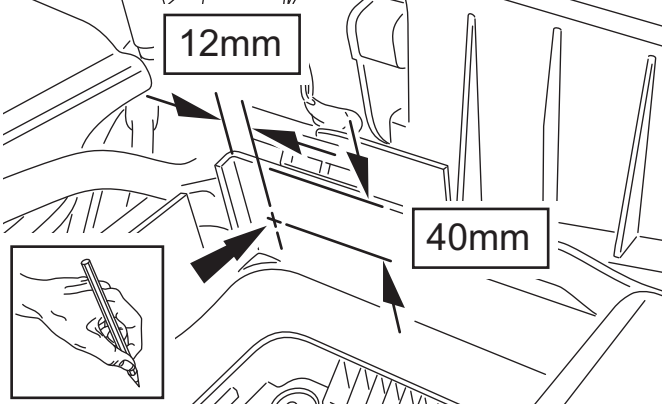

107

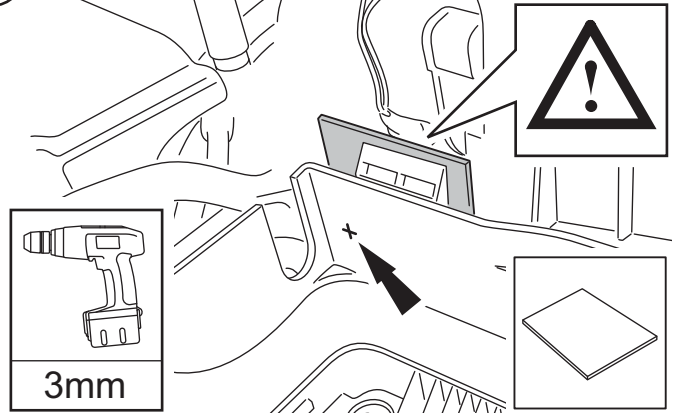

108

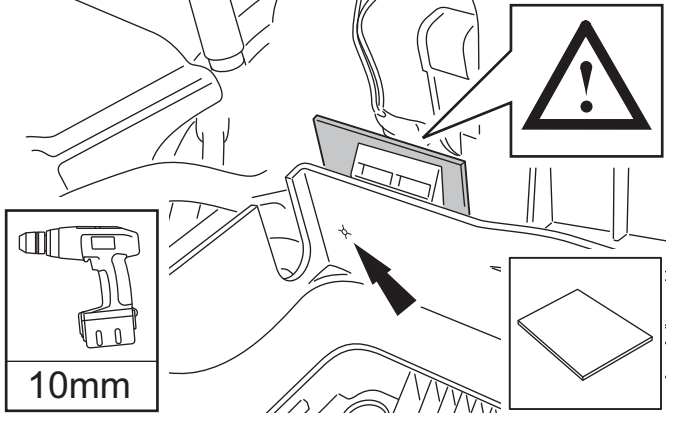

109

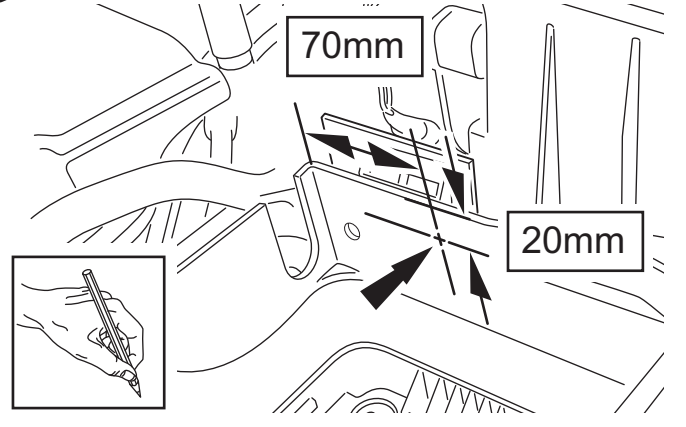

110

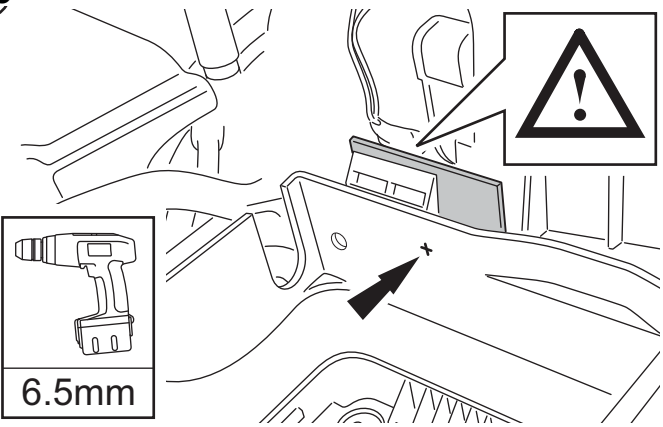

111

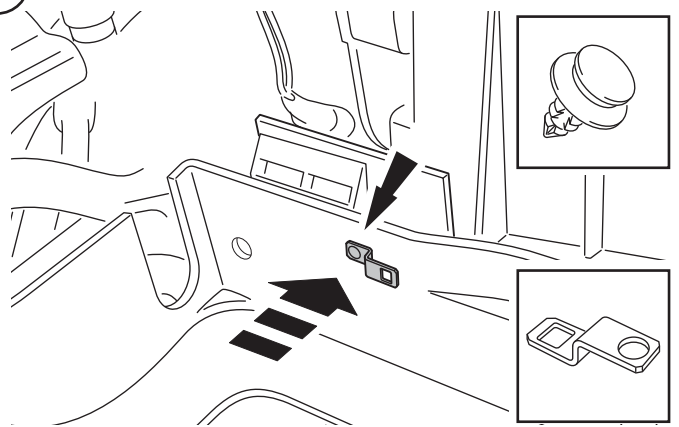

112

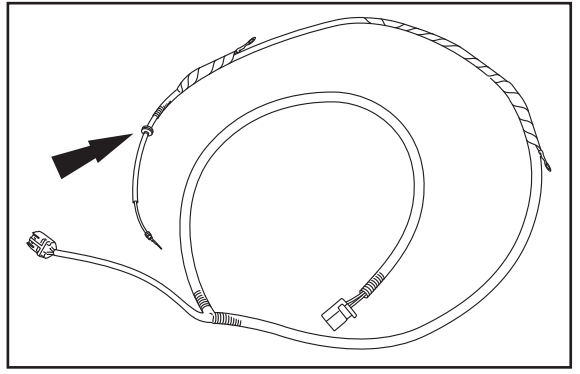
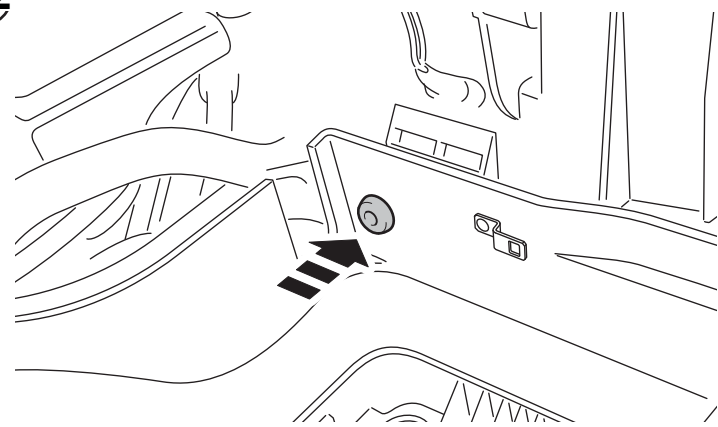

113

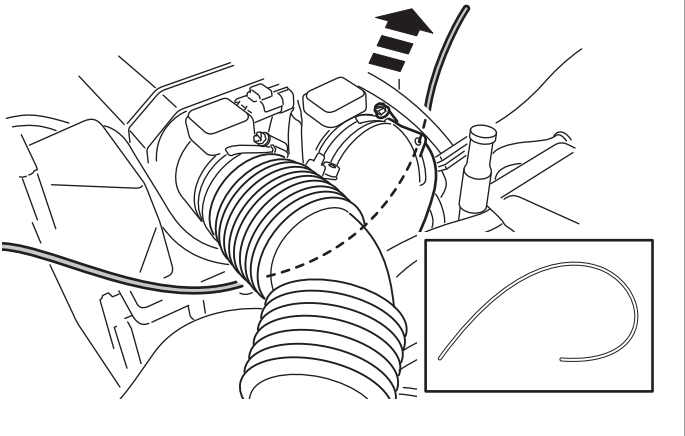

114

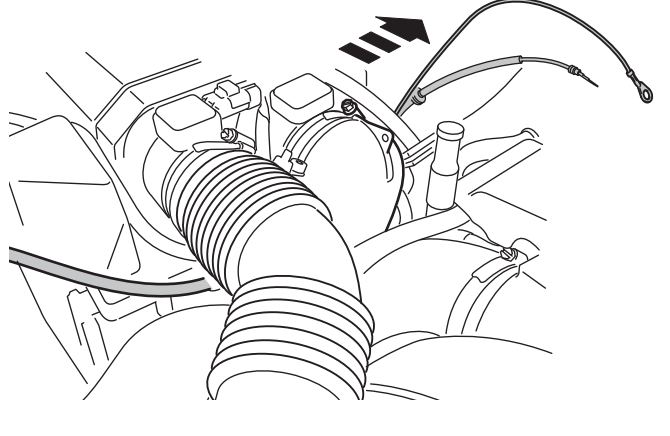

115

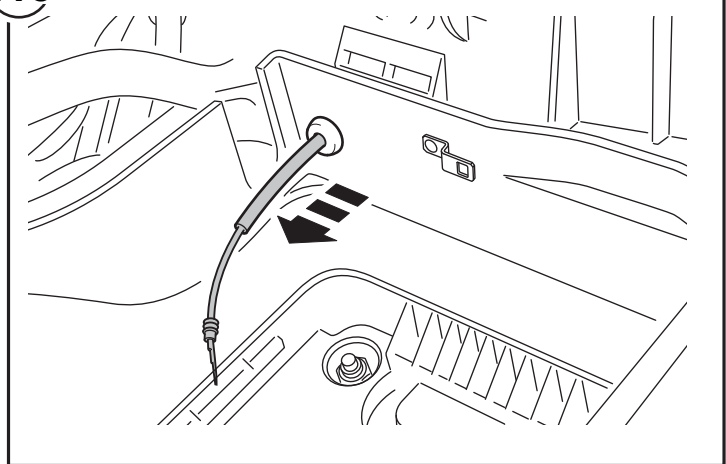

116

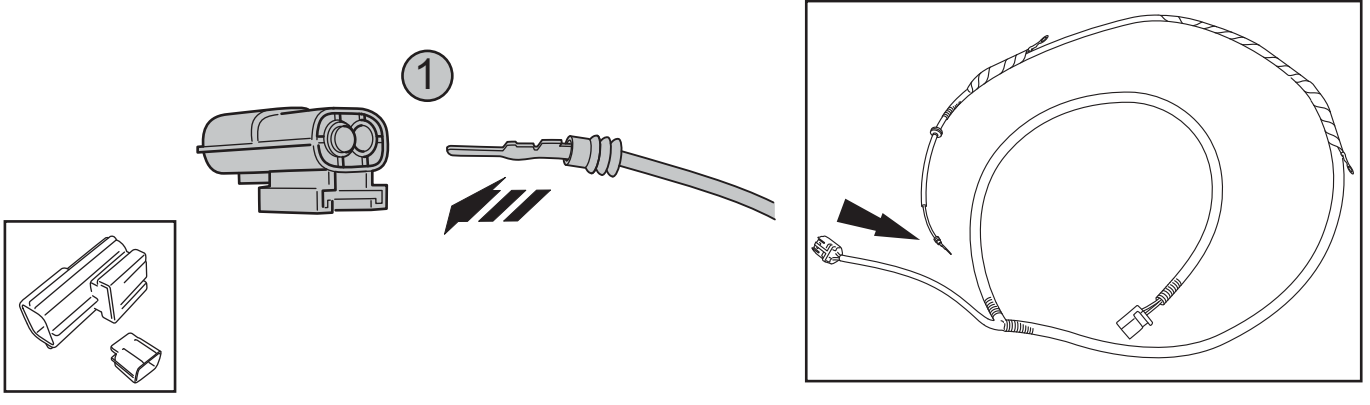

117

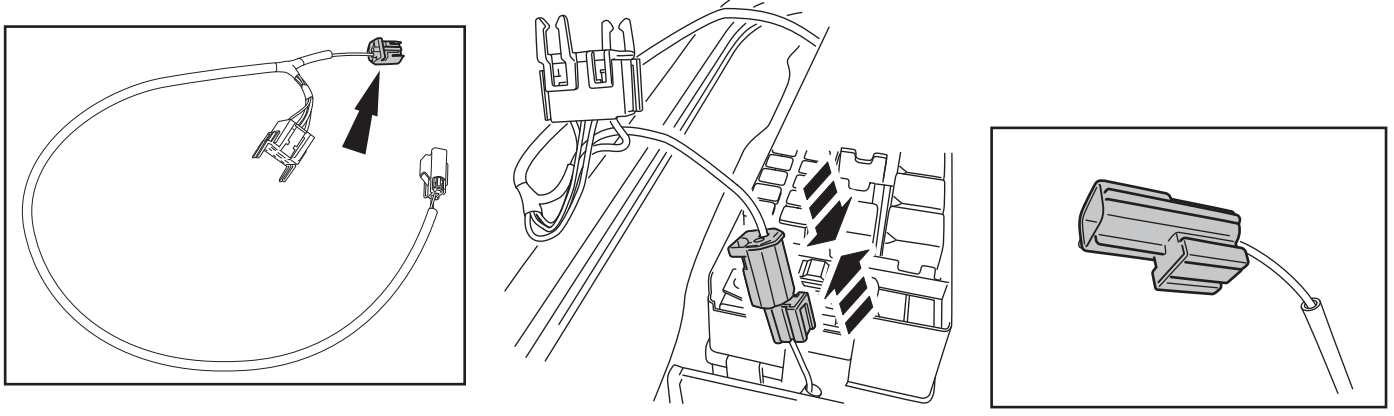

118

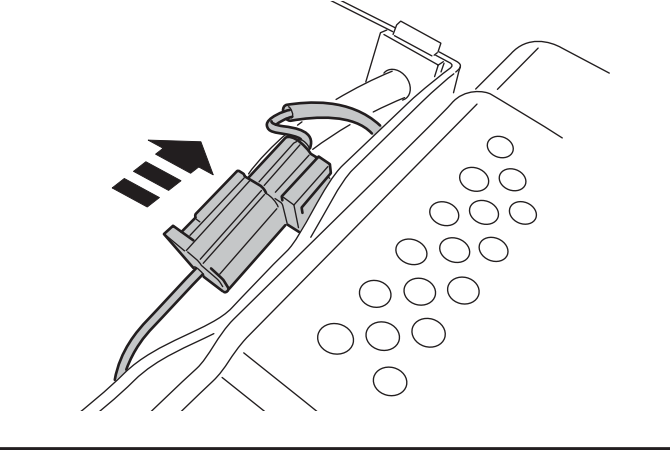

119

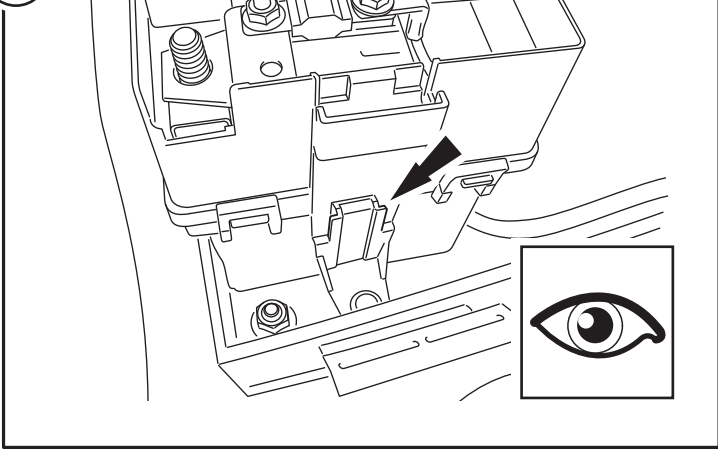

120

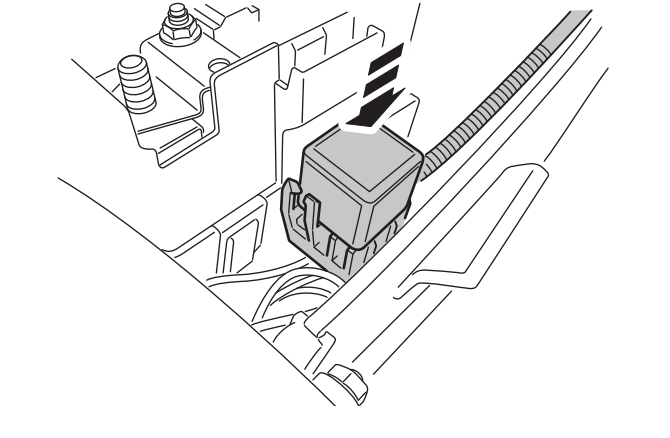

121

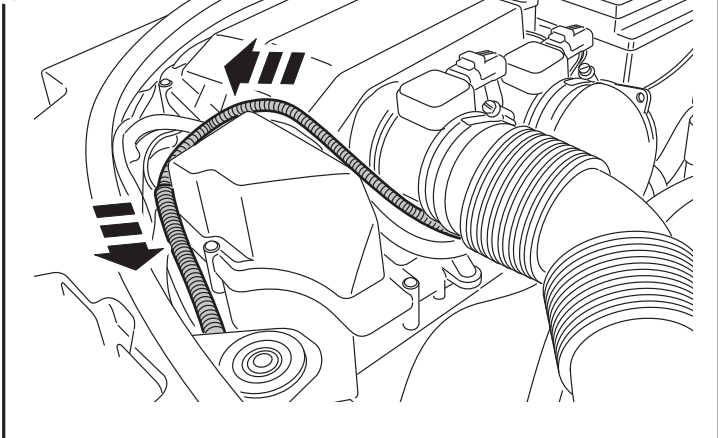

122

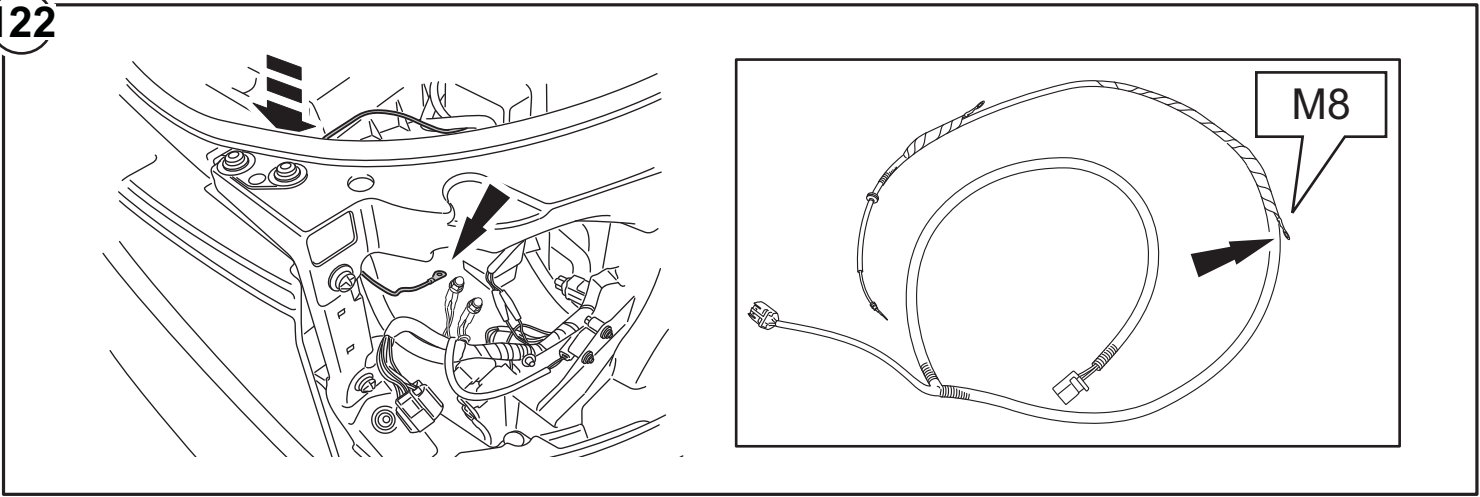

123

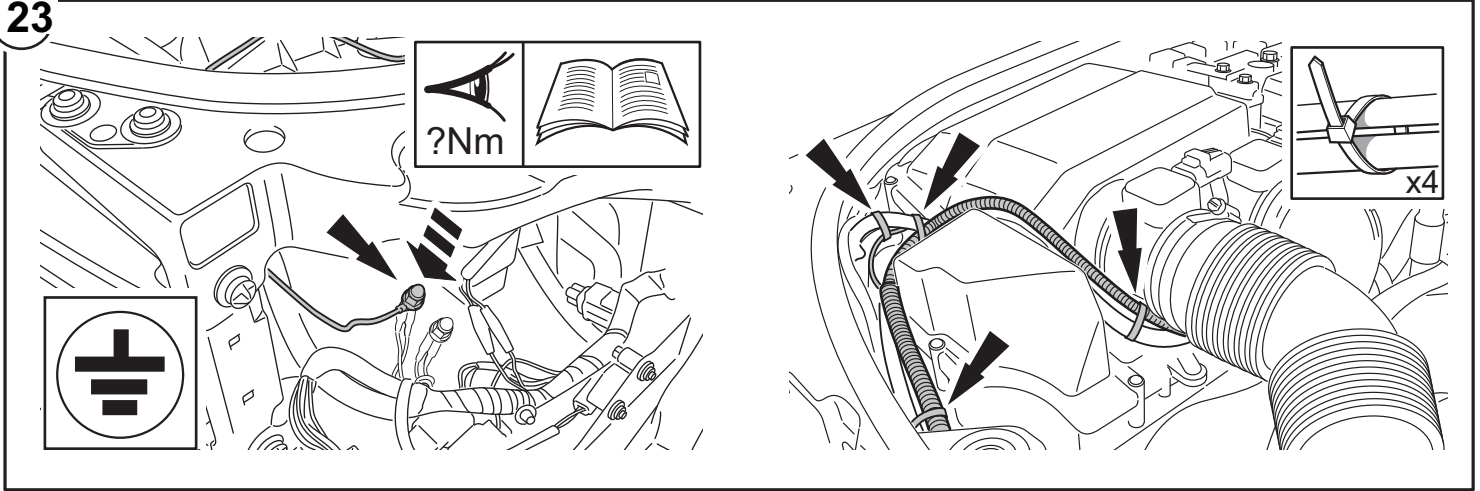

124

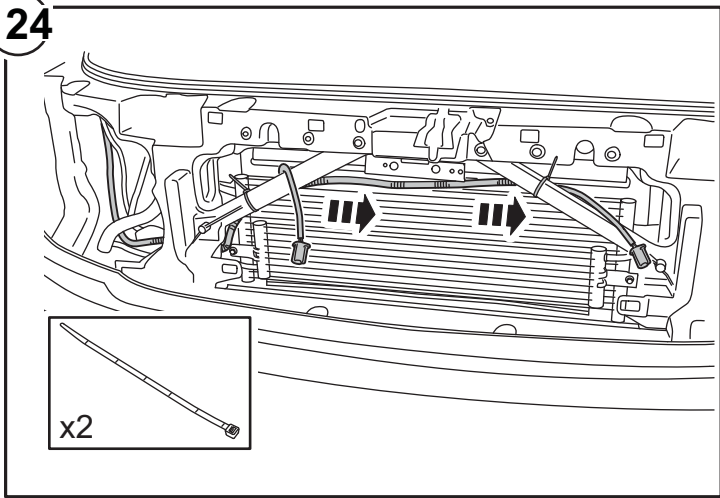

125

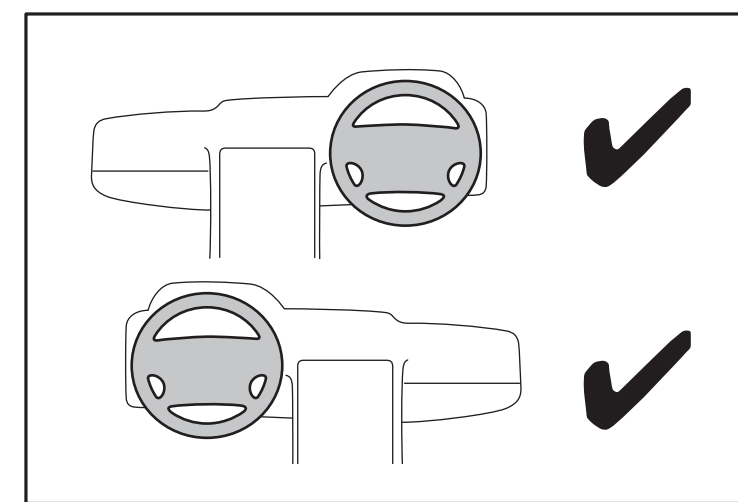
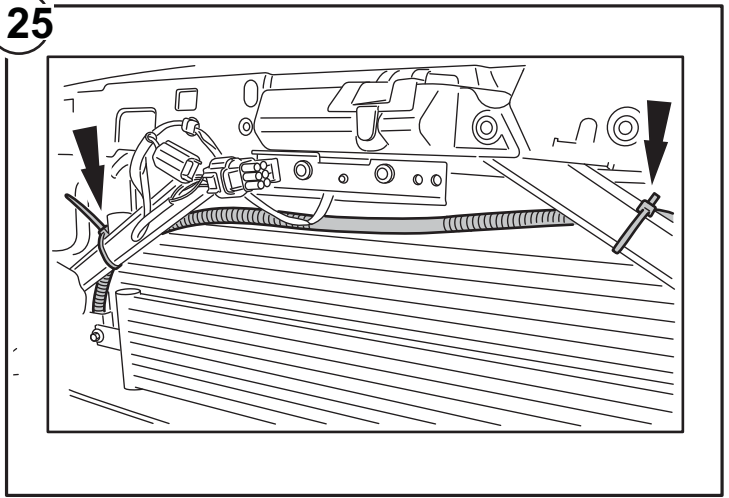

126

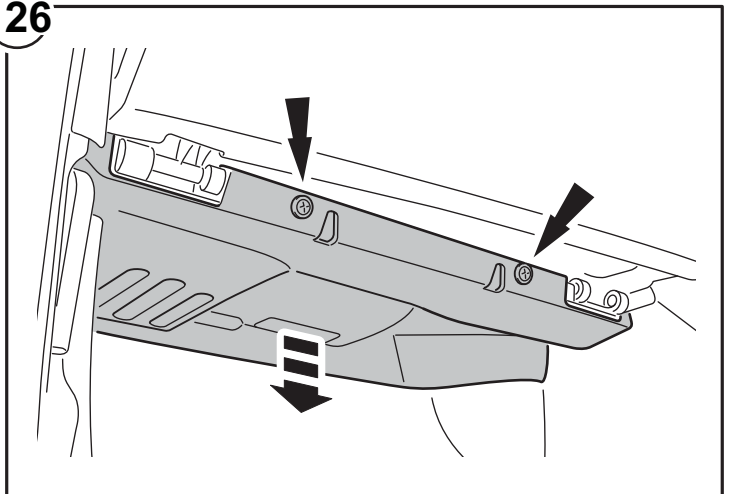

127

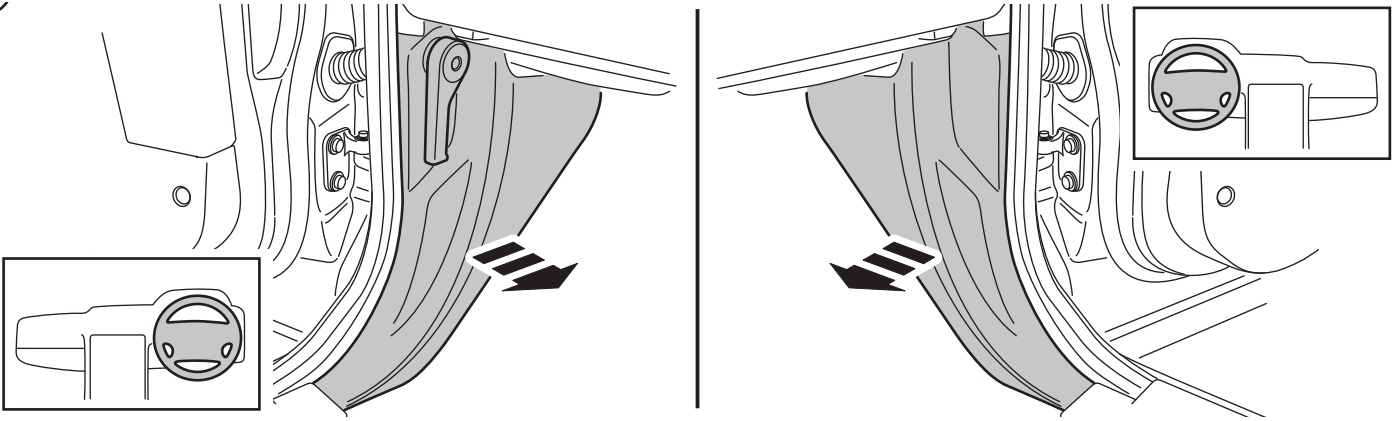

128

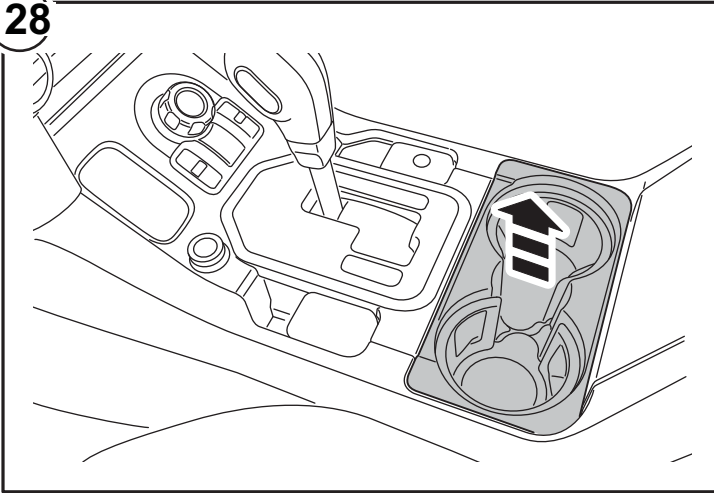

129

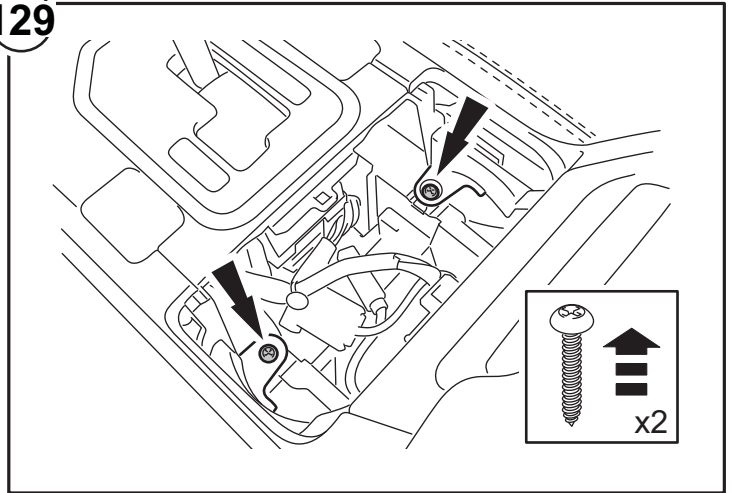

130

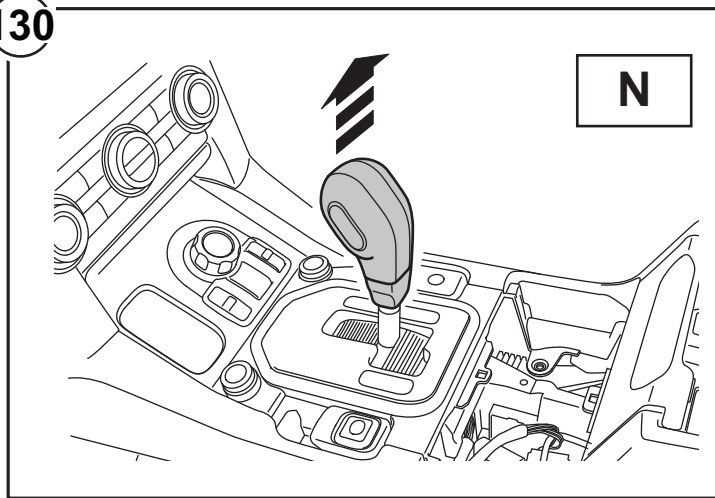

131

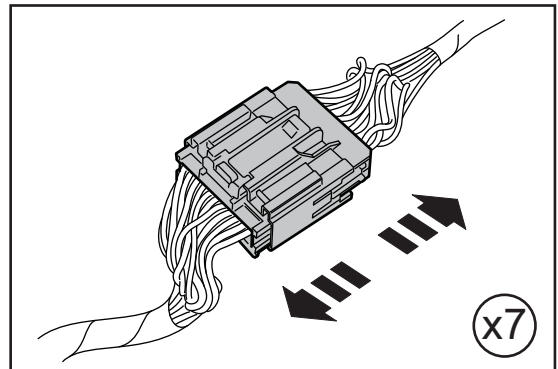
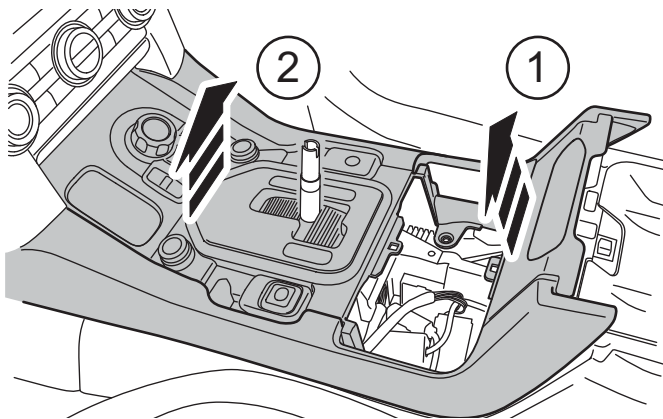

132

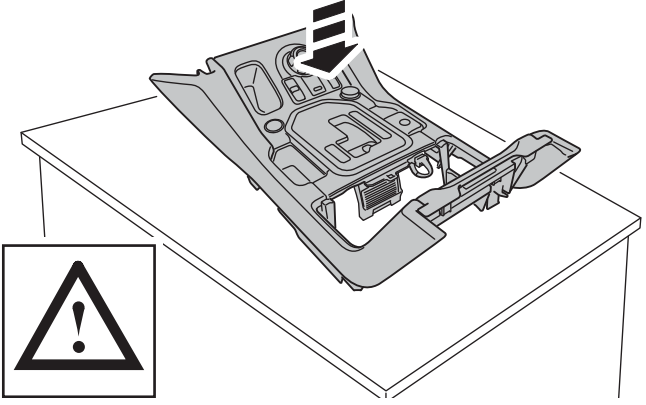

133

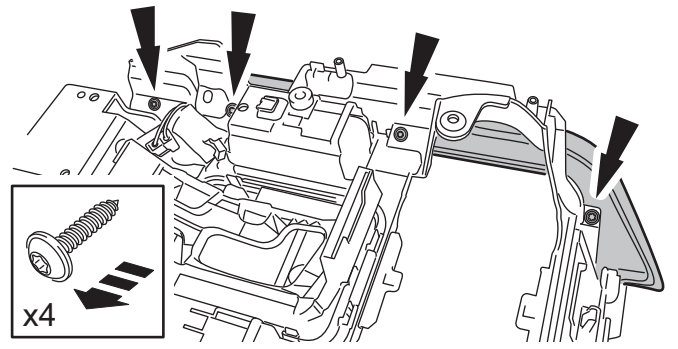

134

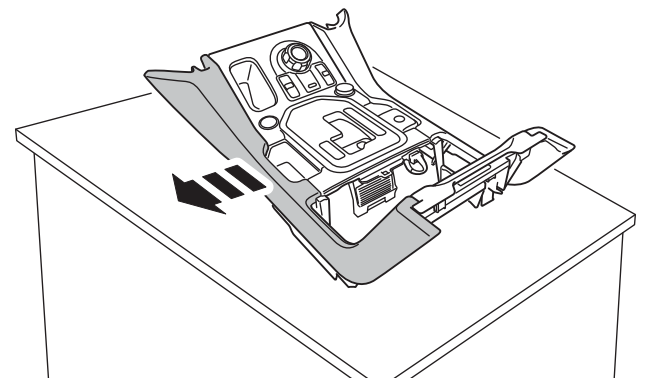

135

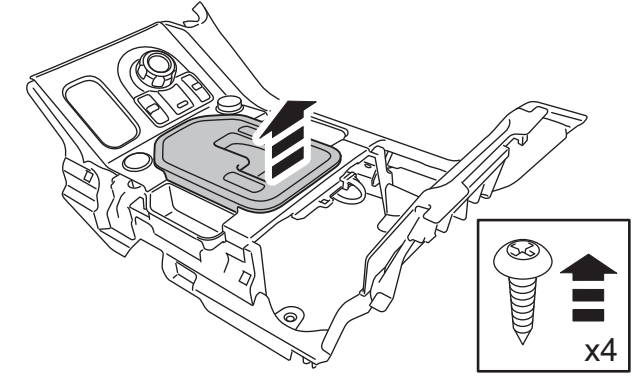

136

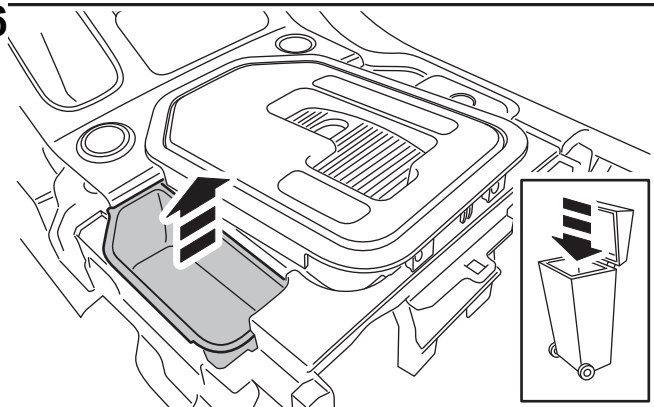

137

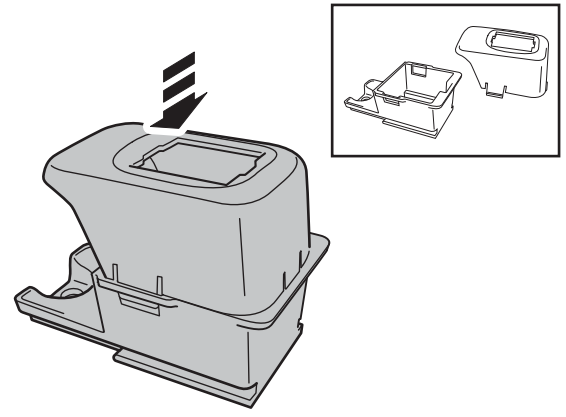

138

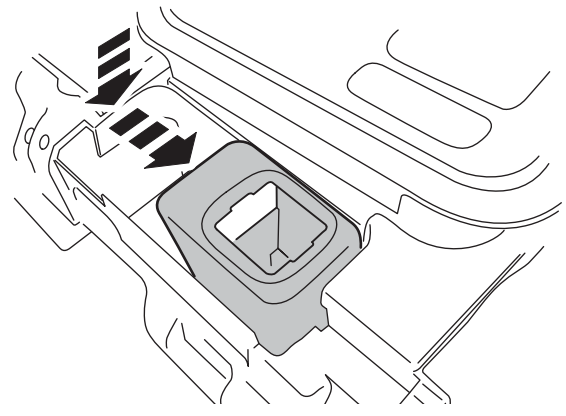

139

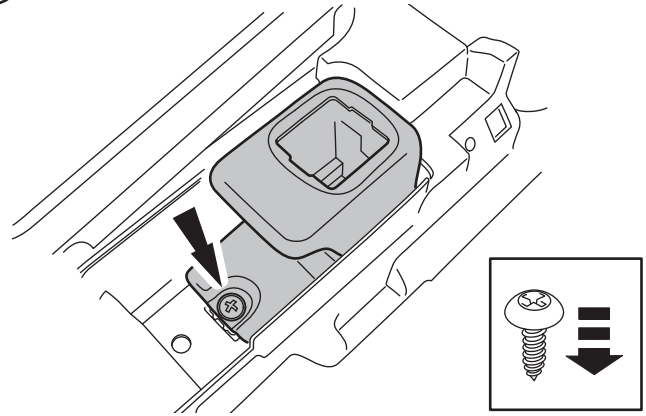

140

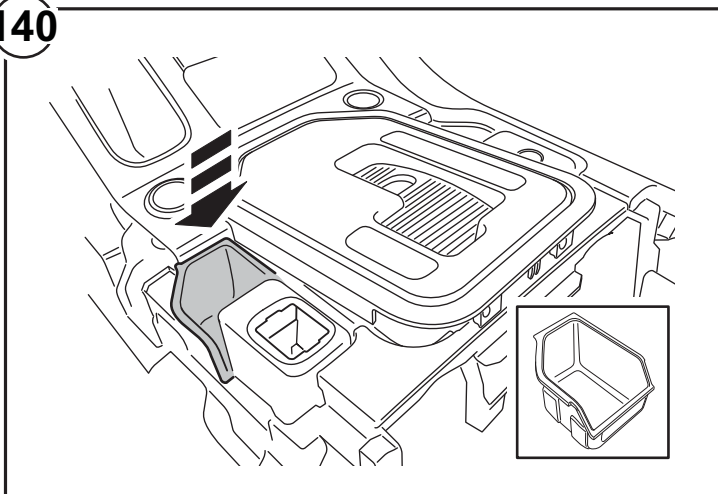

141

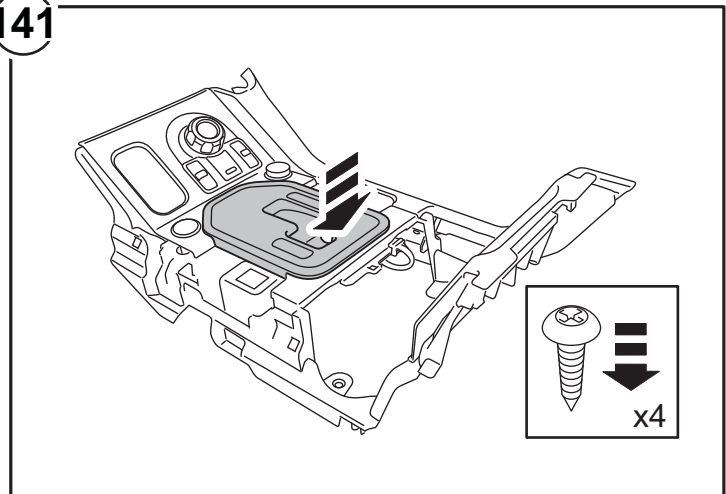

142

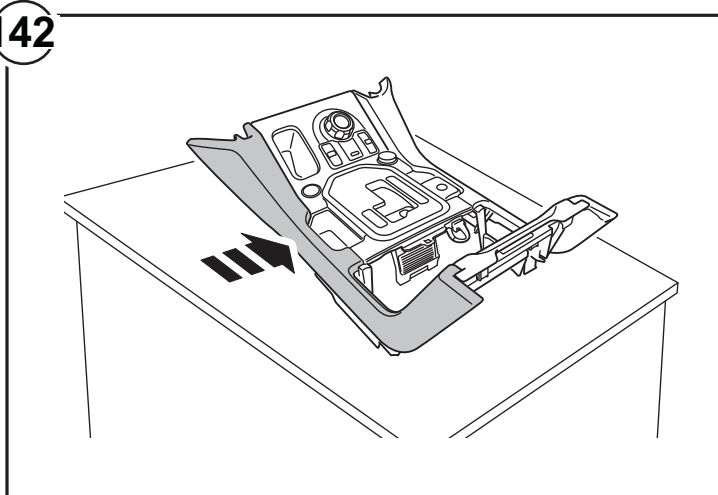

143

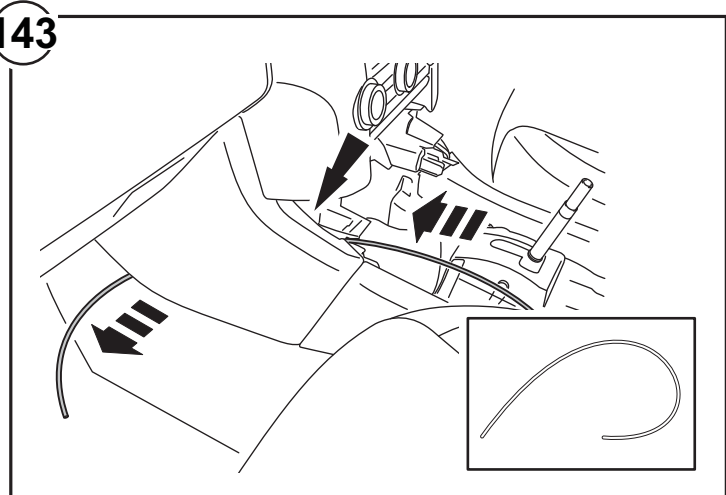

144

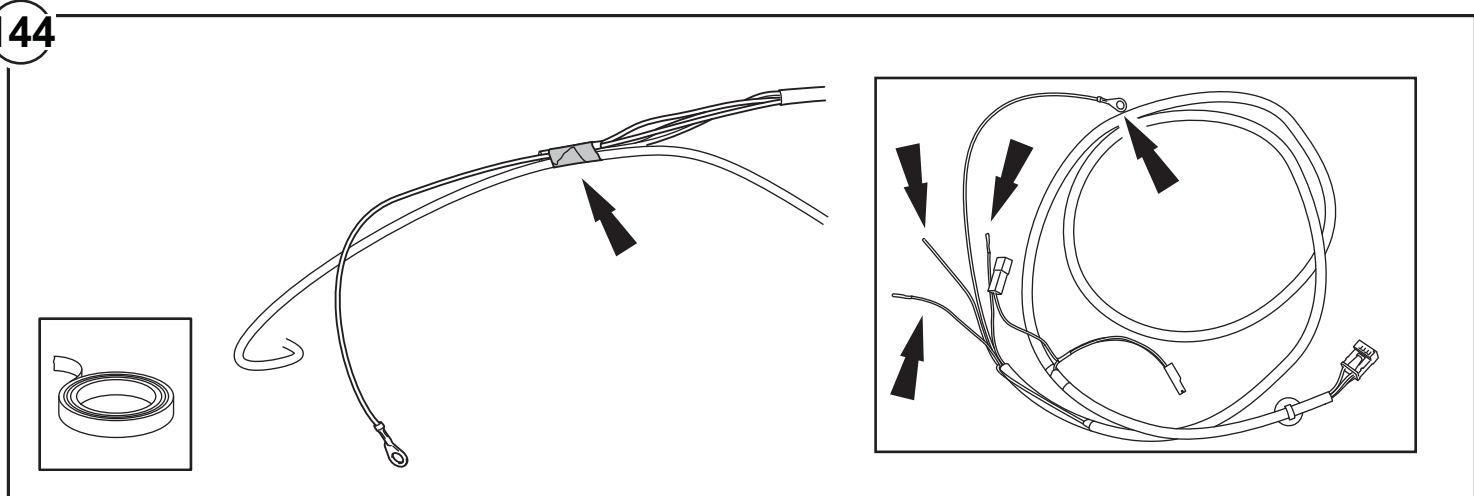

145

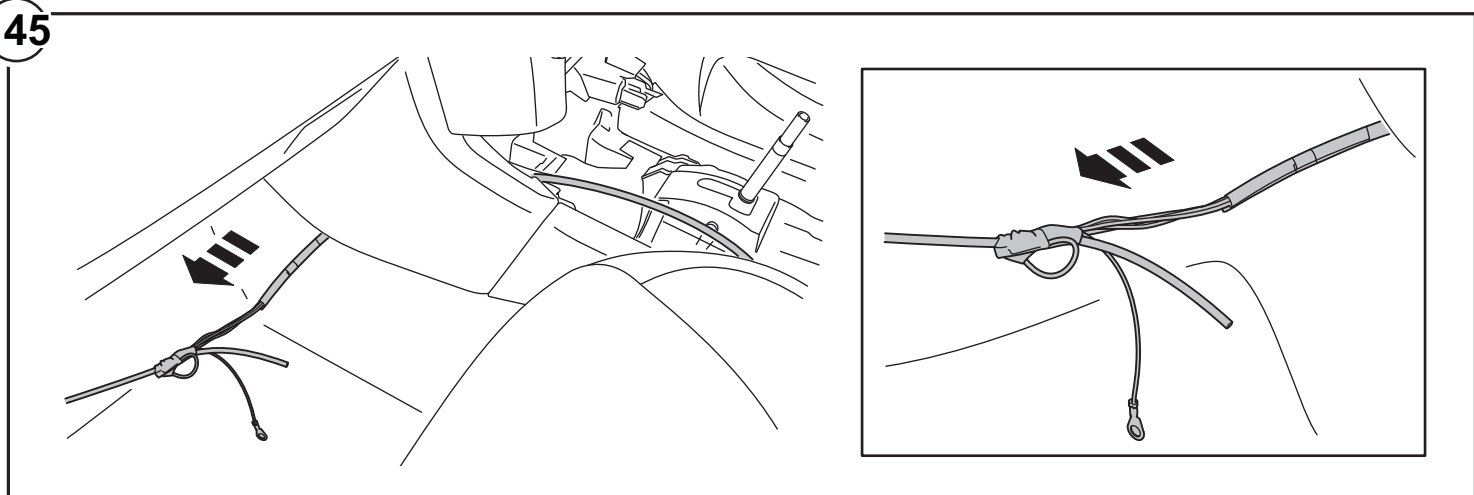

146

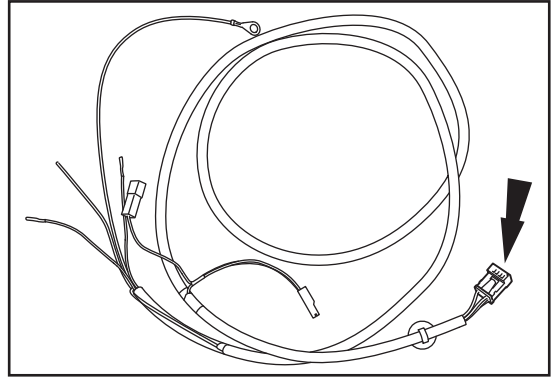
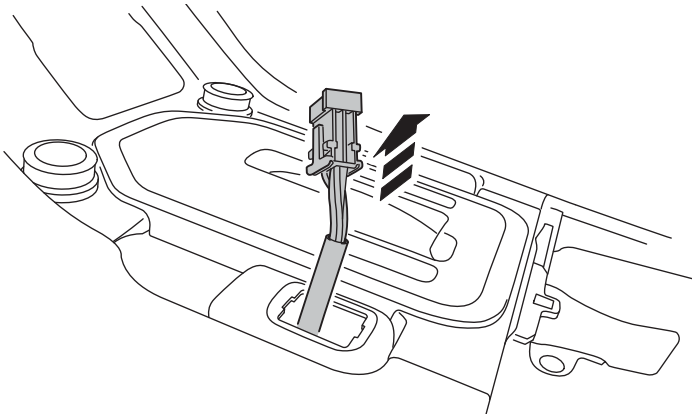

147

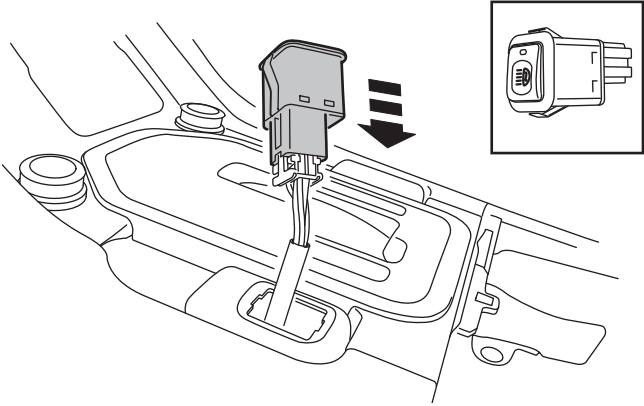

148

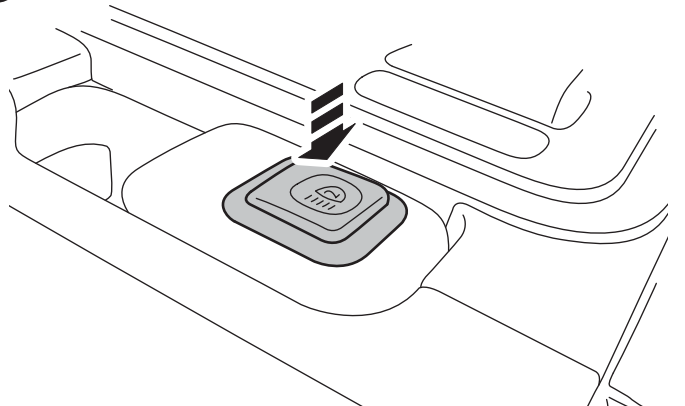

149

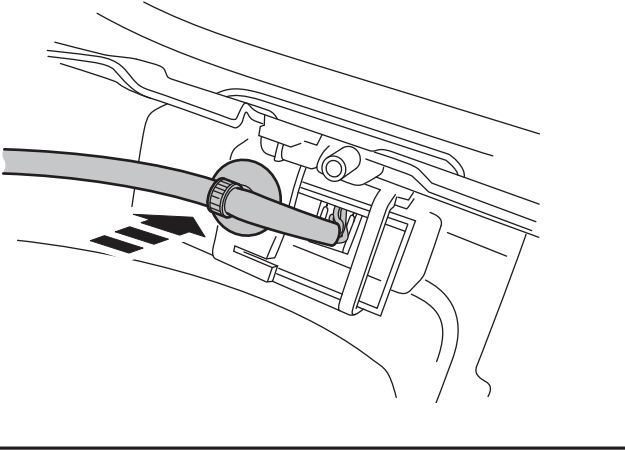

150

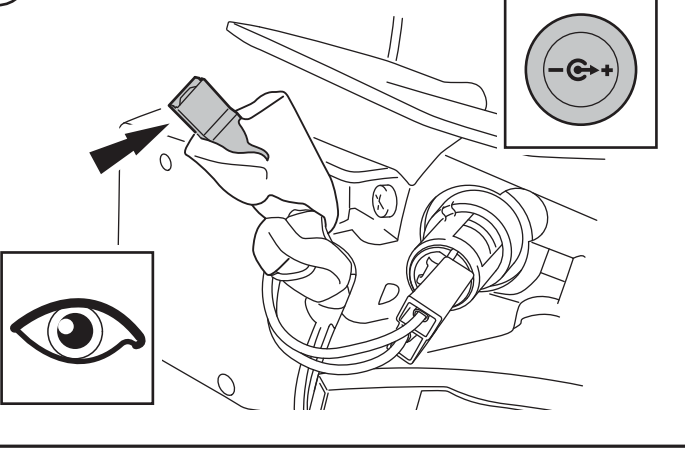

151

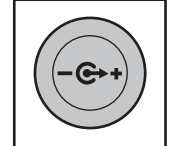
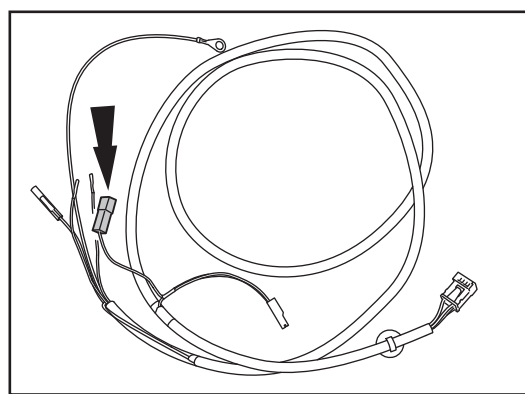
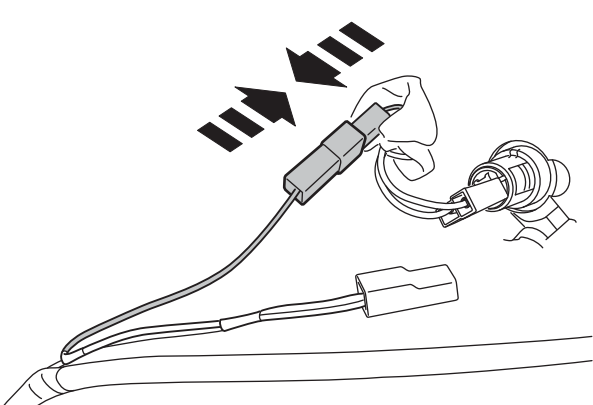

152

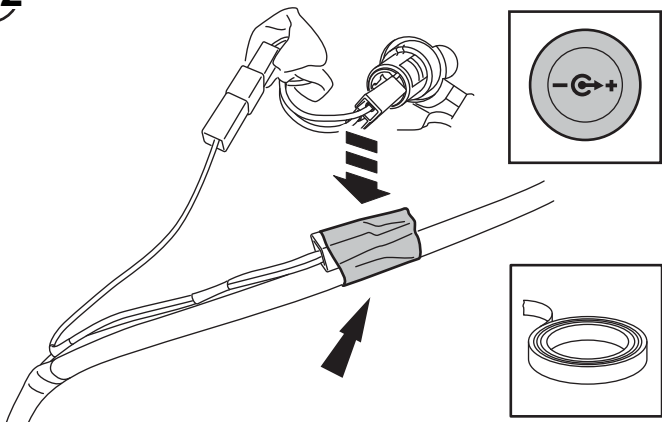

153

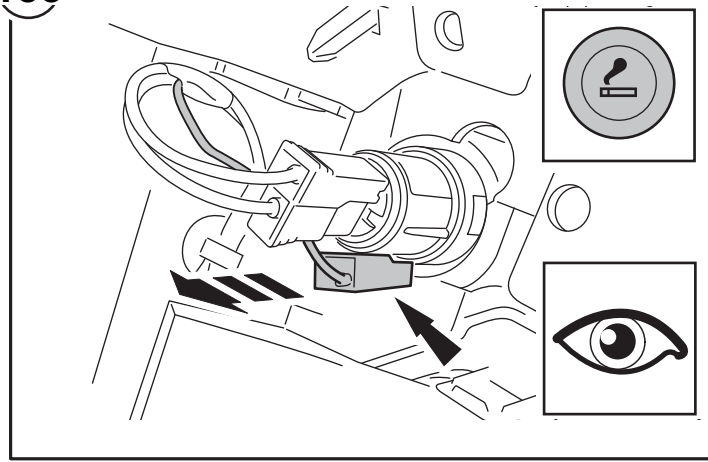

154

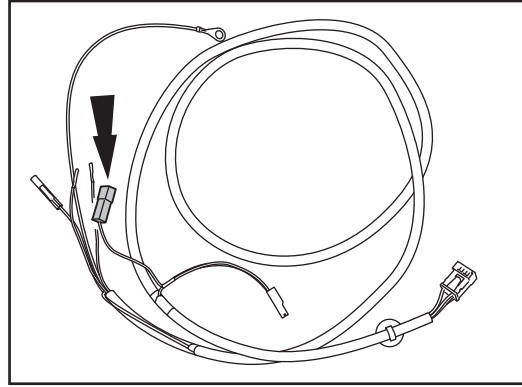
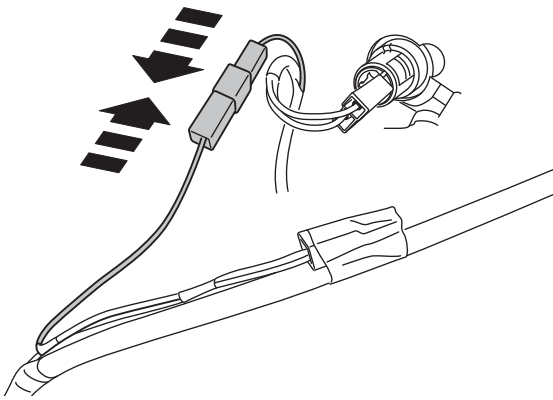

155

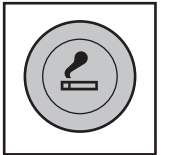
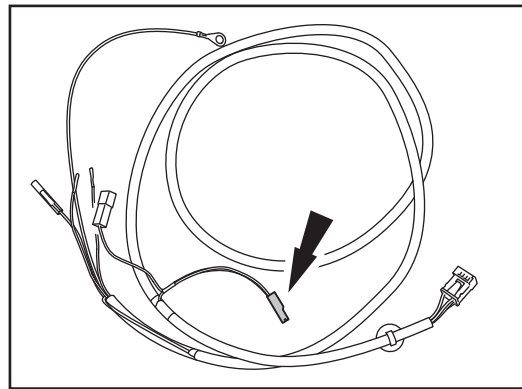
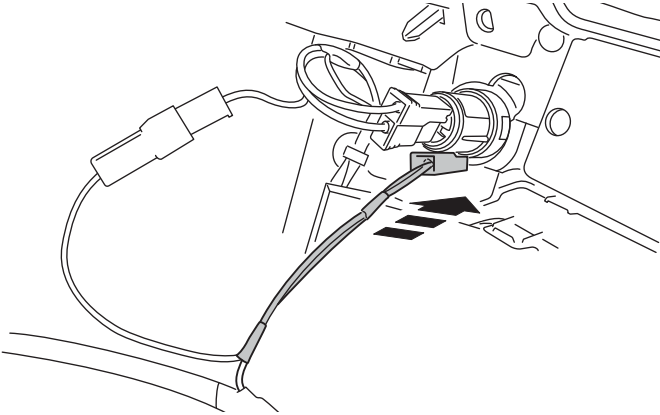

156

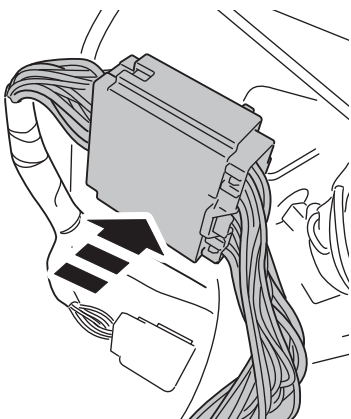

- (GB) Grey
- (D) Grau
- (F) Gris
- (I) Grigio
- (E) Gris
- (P) Cinzento
- (NL) Grijs
- (GR) Γκριζο
- (日) グレー
- (SU) Серый
- (国译) 灰色

157

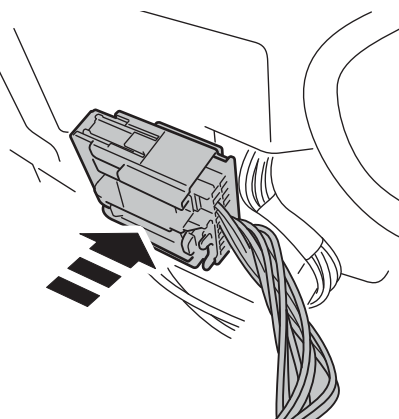

- (GB) Green
- (D) Grün
- (F) Vert
- (I) Verde
- (E) Verde
- (P) Verde
- (NL) Groen
- (GR) πράσινος
- (日) グリーン
- (SU) зеленый
- (国译) 綠色

158

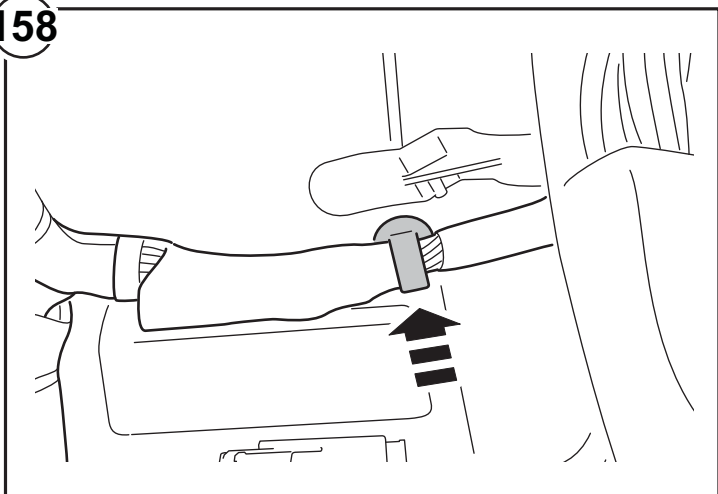

159

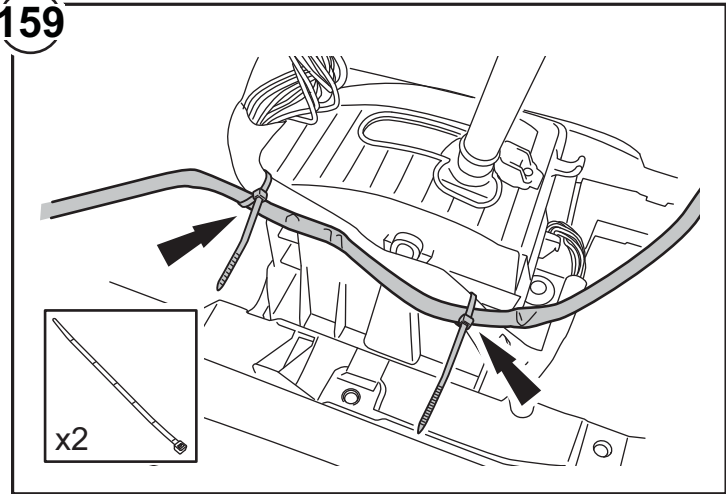

160

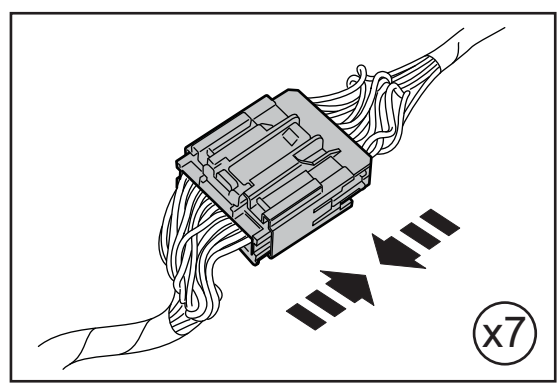
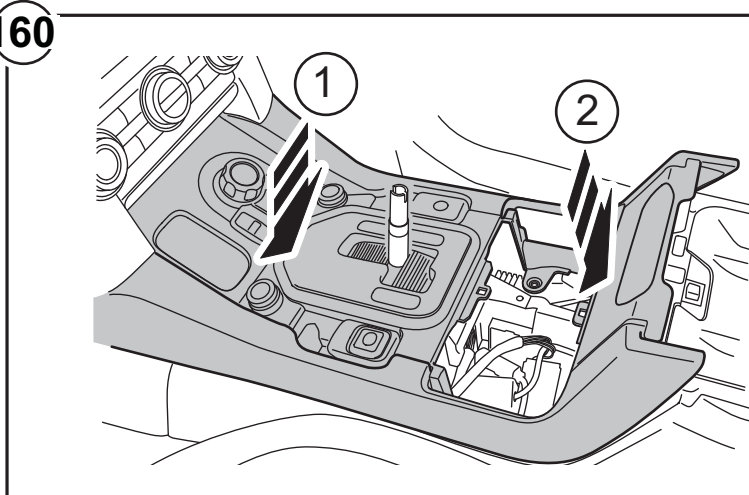

161

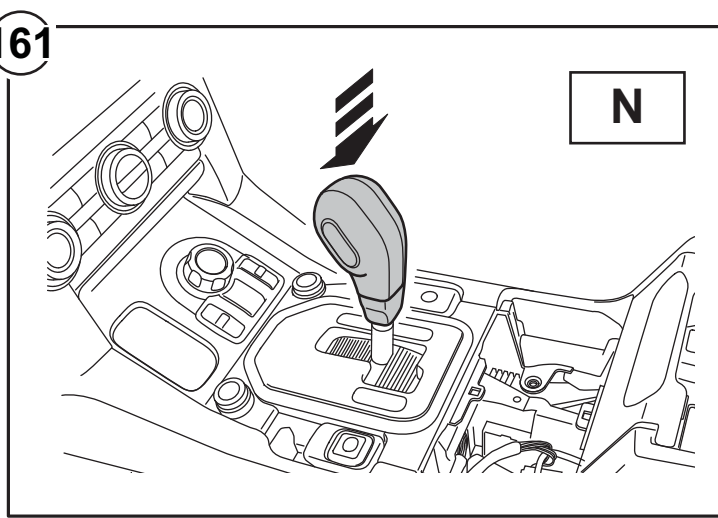

162

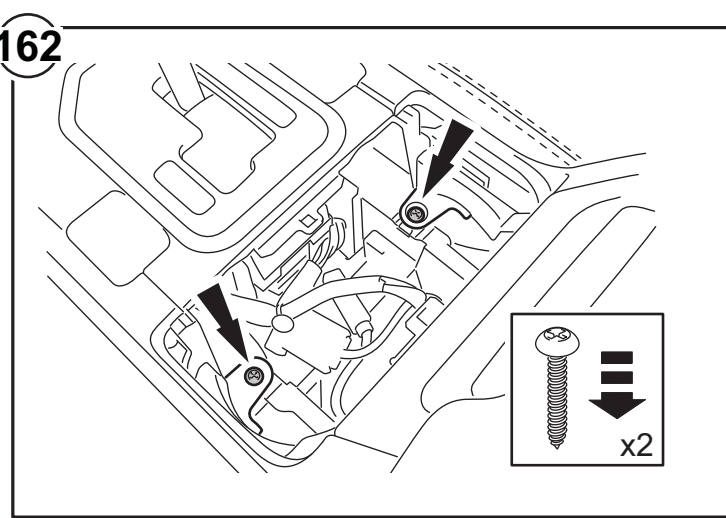

163

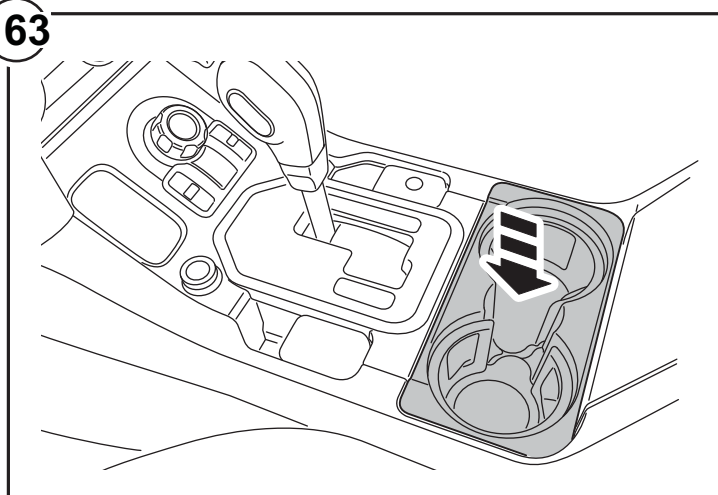

164

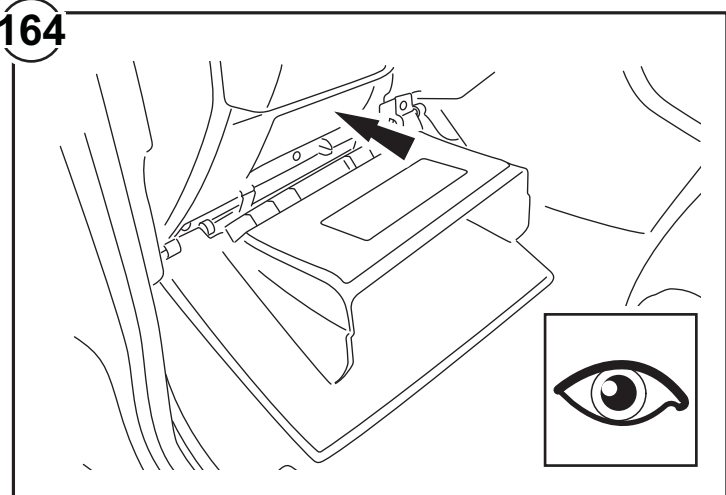

165

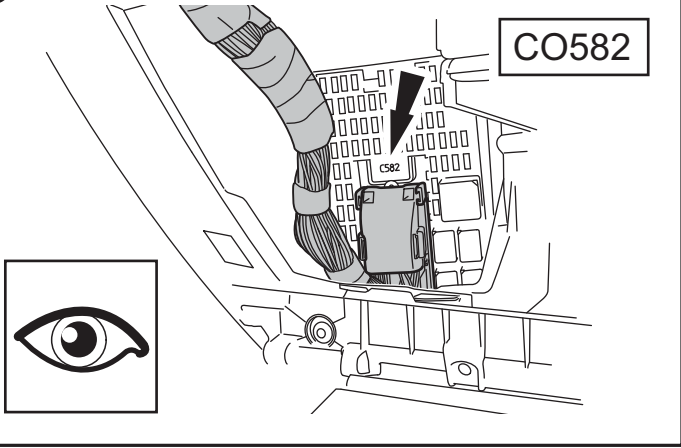

166

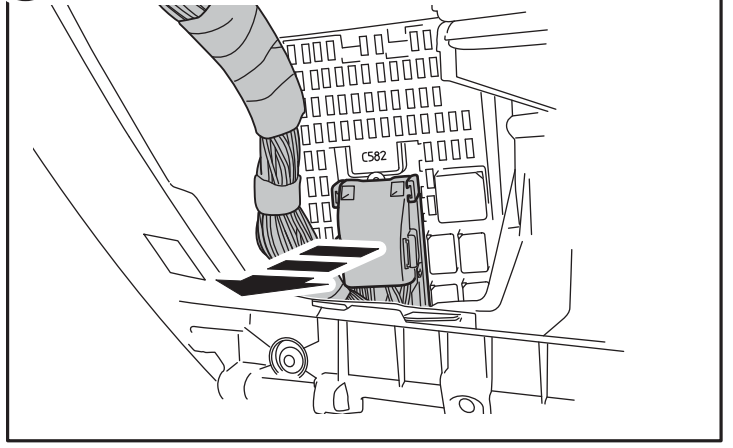

167

- (GB) Green
- (D) Grün
- (F) Vert
- (I) Verde
- (E) Verde
- (P) Verde
- (NL) Groen
- (GR) πράσινος
- (日) グリーン
- (SU) зеленый
- (国語) 緑色

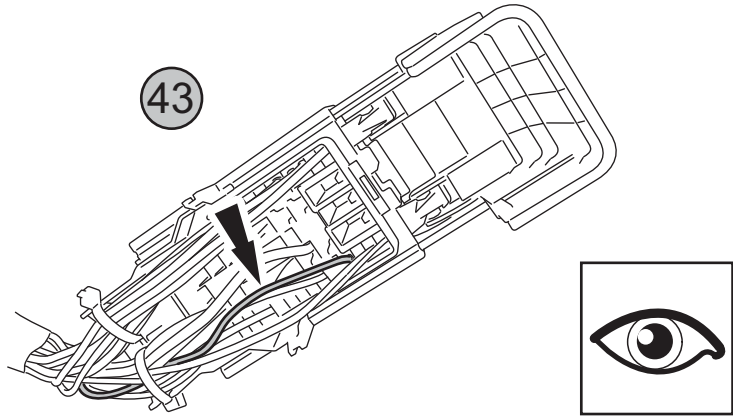

168

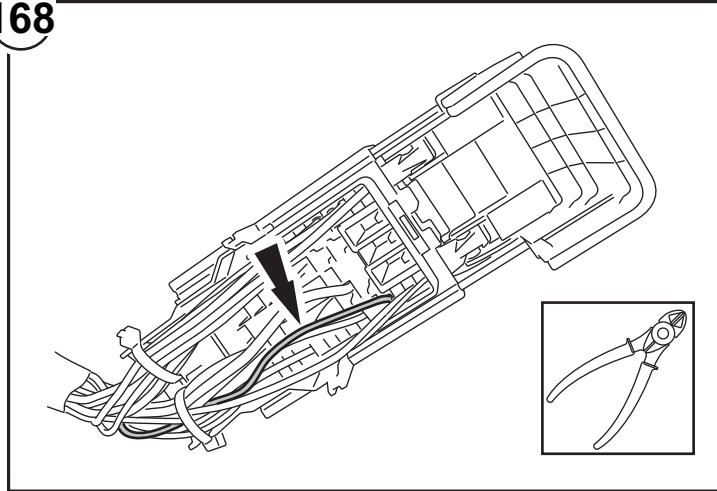

169

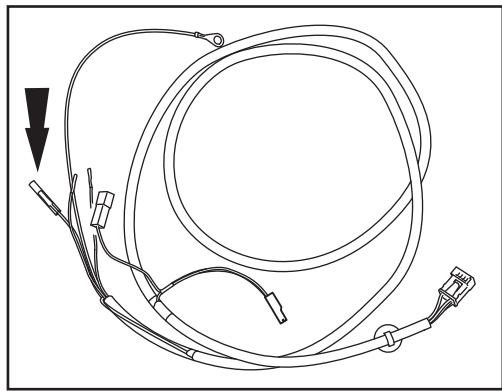
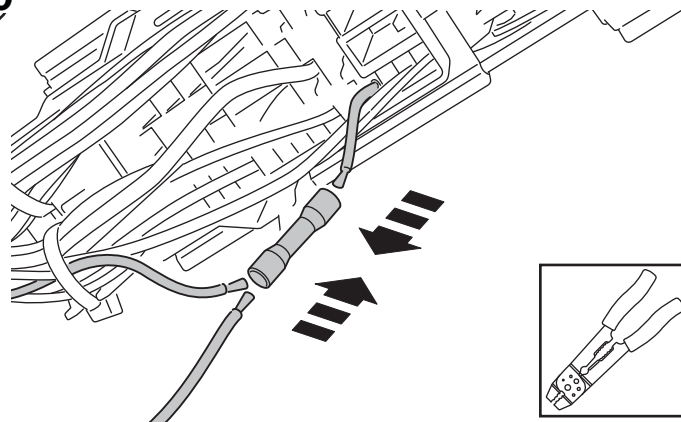

- (GB) Black
- (D) Schwarz
- (F) Noir
- (I) Nero
- (E) Negro
- (P) Preto
- (NL) Zwart
- (GR) μαύρος
- (日) ブラック
- (SU) черный
- (国語) 黑色

170

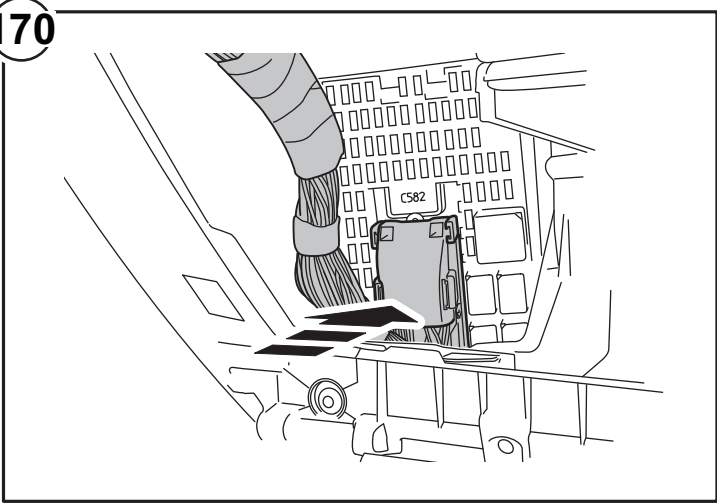

171

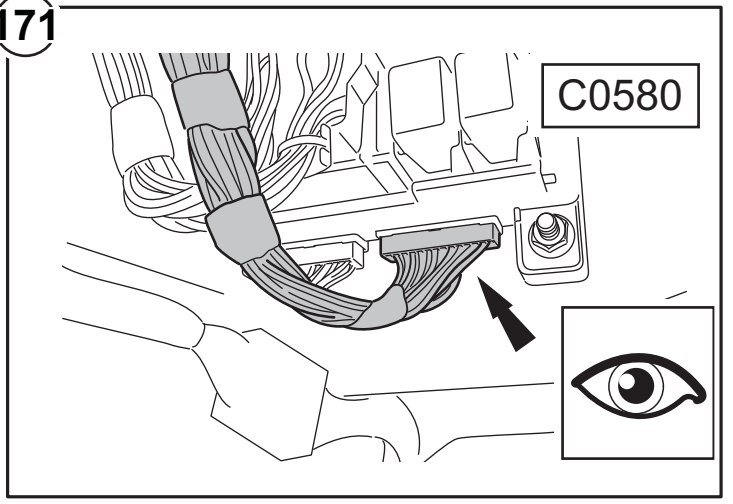

172

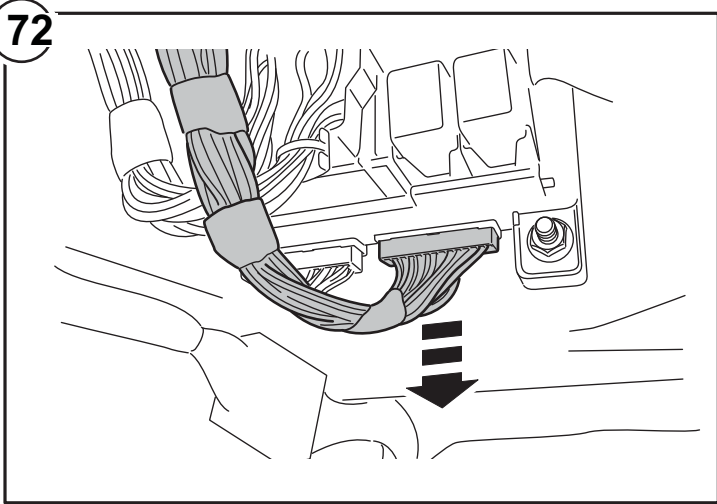

173

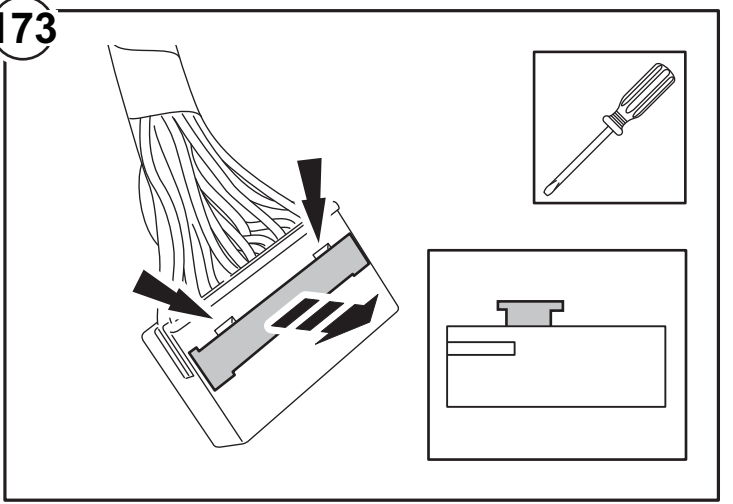

174

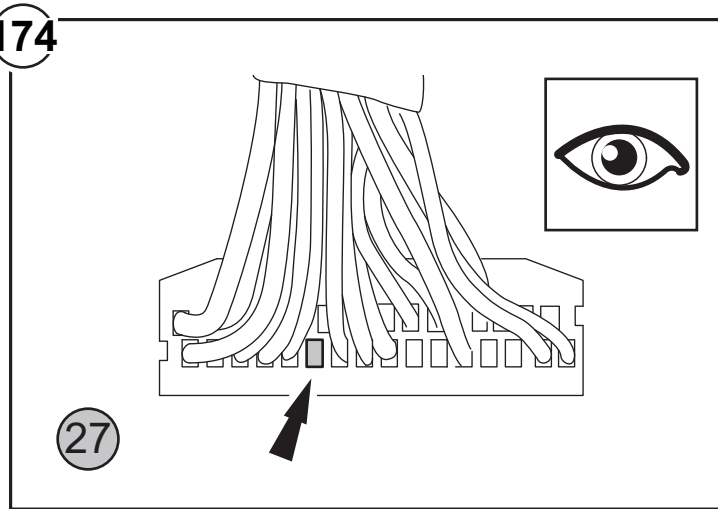

175

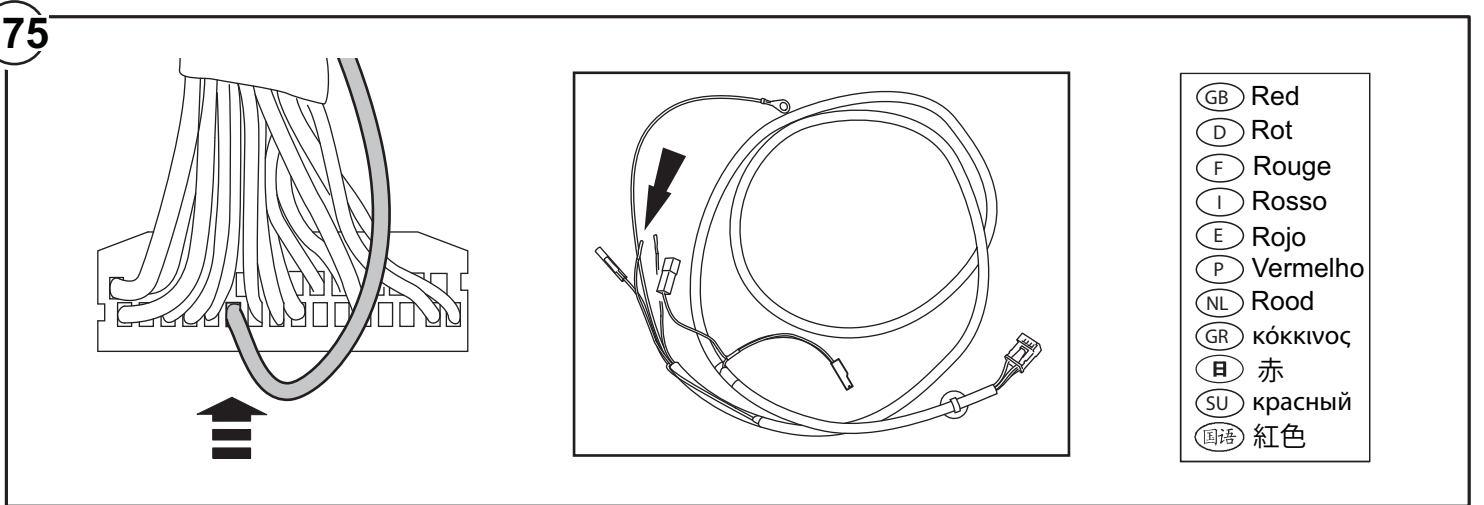

176

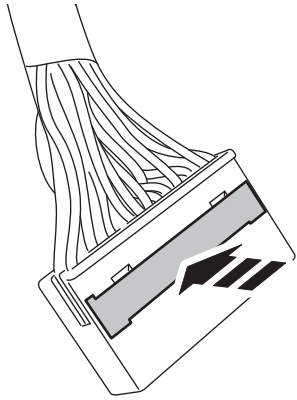

177

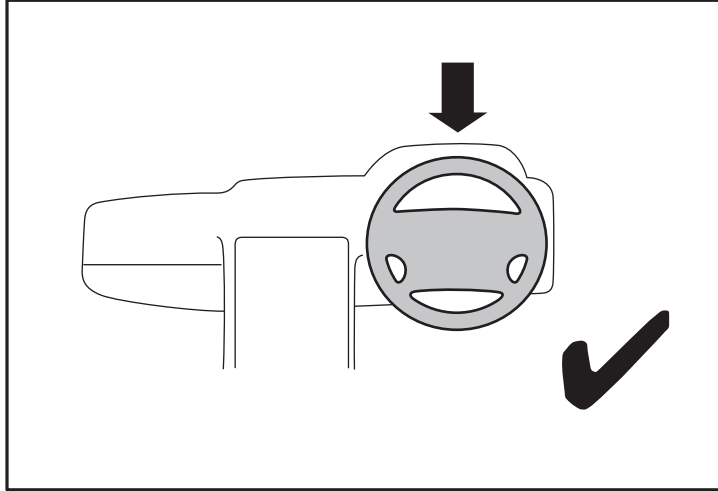
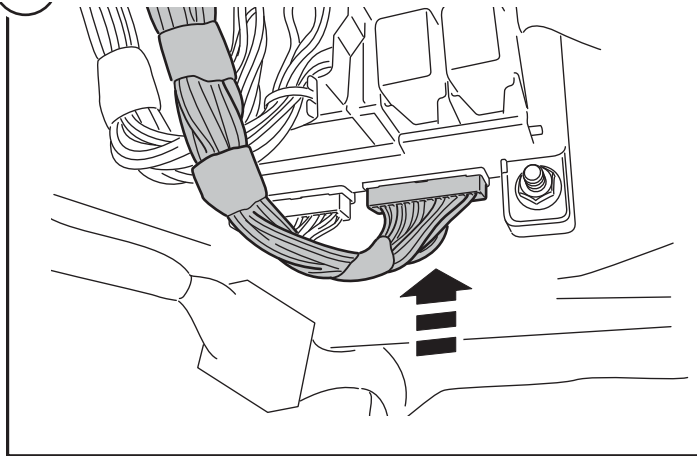

178

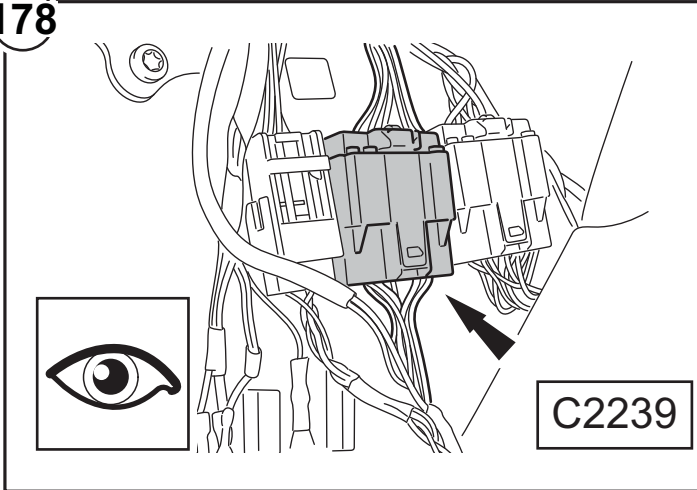

179

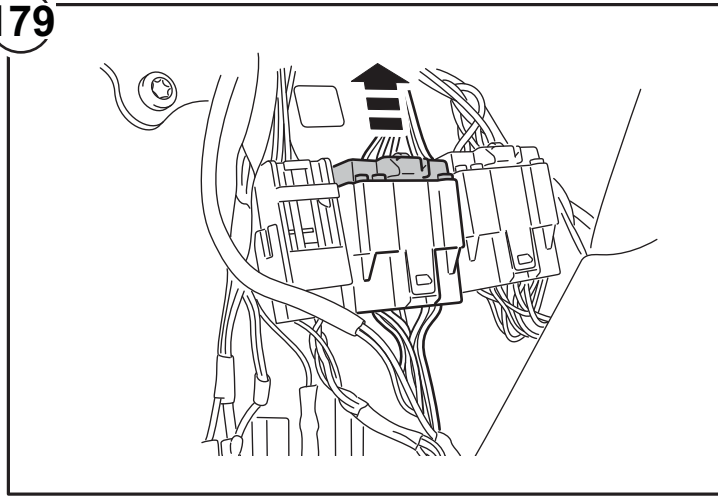

180

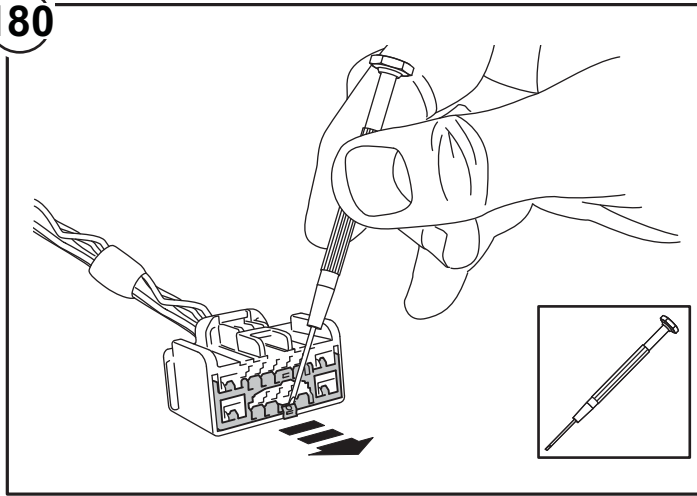

181

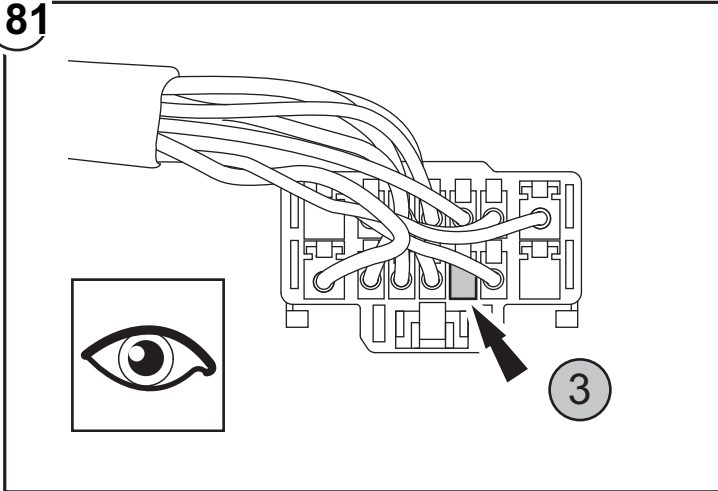

182

- (GB) Green / Yellow
- (D) Grün / Gelb
- (F) Vert / Jaune
- (I) Verde / Giallo
- (E) Verde / Amarillo
- (P) Verde / Amarelo
- (NL) Groen / Geel
- (GR) Πράσινο / Κίτρινο
- (日) イエロー/グリーン
- (SU) Зеленый / желтый
- (国語) 緑色/黄色

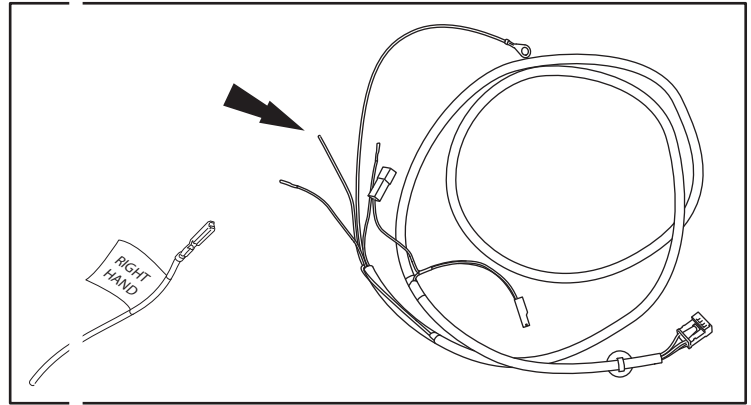

- (GB) Right Hand Drive
- (D) Rechtssteuerung
- (F) Conduite a Droite
- (I) Volante a la Destra
- (E) Volante a la Derecha
- (P) Mão Direita unidade
- (NL) Rechtsgestuurde Versies
- (GR) ΑΡΙΣΤΕΡΟΤΙΜΟΝΟ
- (日) 右ハンドル
- (SU) Автомобиль с правым рулем
- (国語) 右座驾驶

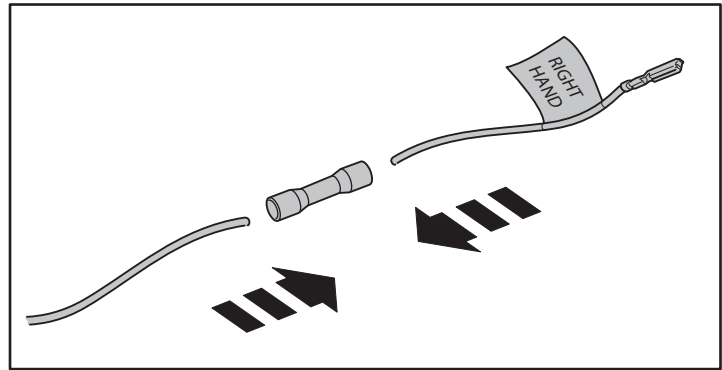

183

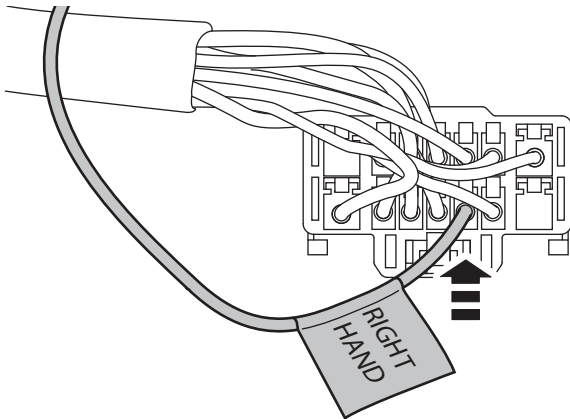

- (GB) Green / Yellow
- (D) Grün / Gelb
- (F) Vert / Jaune
- (I) Verde / Giallo
- (E) Verde / Amarillo
- (P) Verde / Amarelo
- (NL) Groen / Geel
- (GR) Πράσινο / Κίτρινο
- (日) イエロー/グリーン
- (SU) Зеленый / желтый
- (国語) 緑色/黄色

184

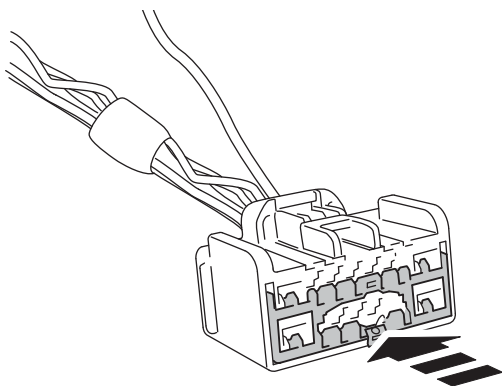

185

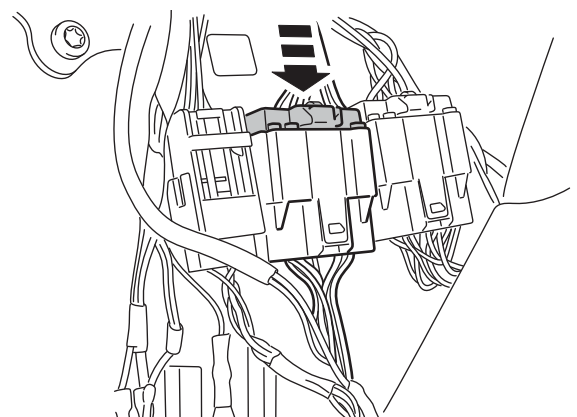

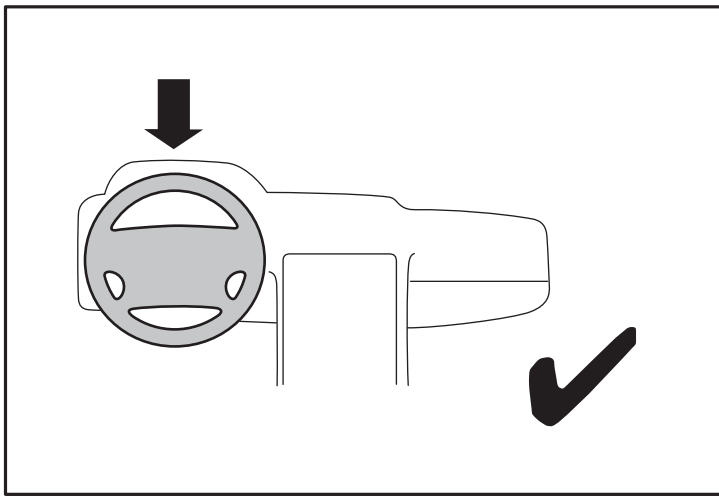

186

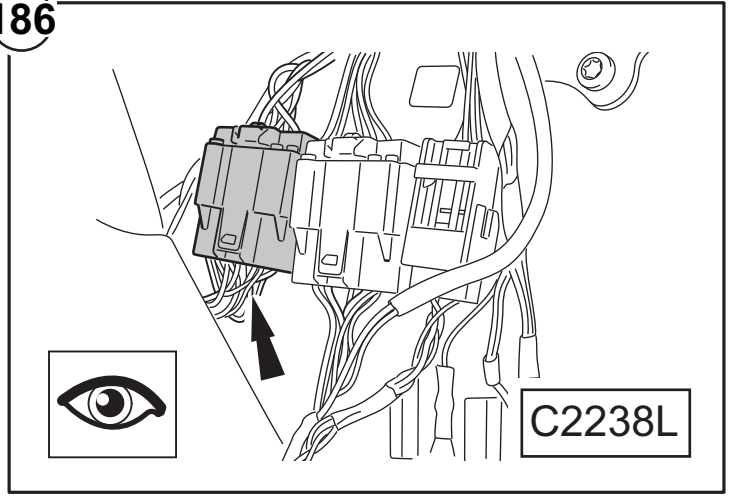

187

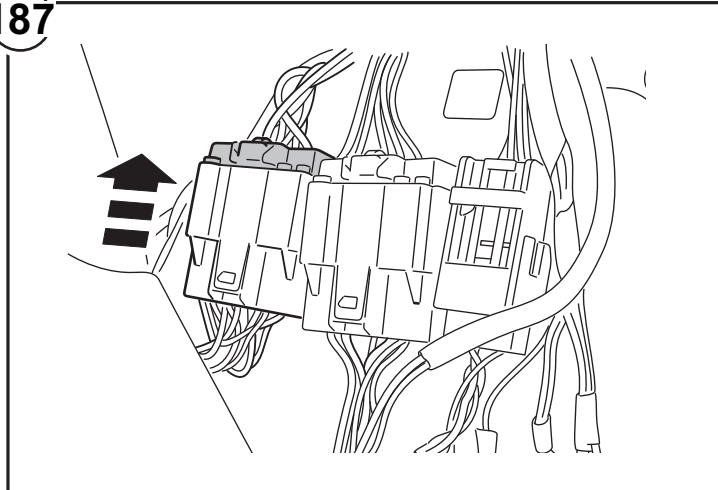

188

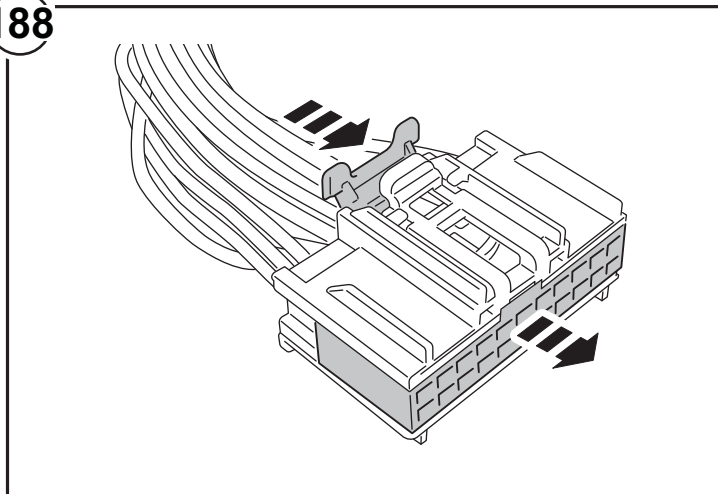

189

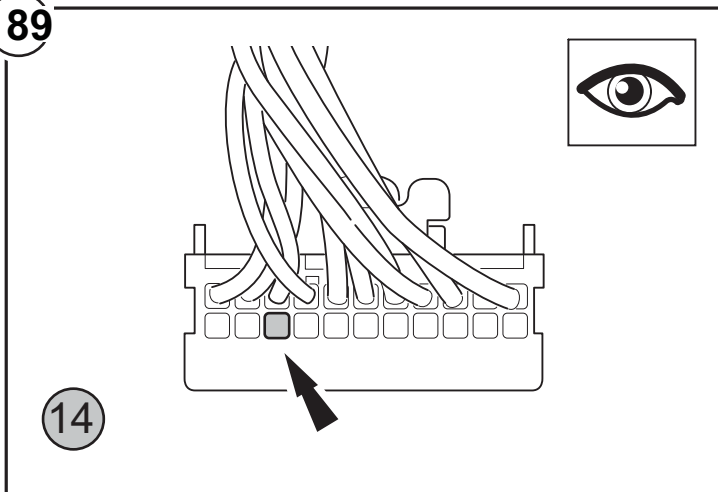

190

- (GB) Green / Yellow
- (D) Grün / Gelb
- (F) Vert / Jaune
- (I) Verde / Giallo
- (E) Verde / Amarillo
- (P) Verde / Amarelo
- (NL) Groen / Geel
- (GR) Πράσινο / Κίτρινο
- (日) イエロー/グリーン
- (SU) Зеленый / желтый
- (国語) 緑色/黄色

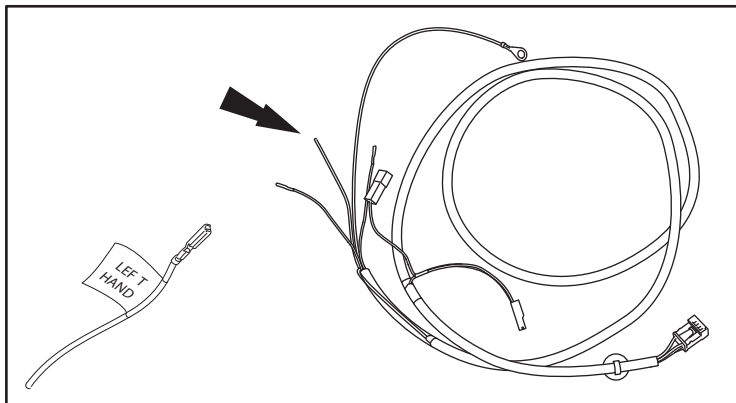

- (GB) Left Hand Drive
- (D) Linkssteuerung
- (F) Conduite a Gauche
- (I) Volante a la Sinistra
- (E) Volante a la Izquierda
- (P) Passeio da Mão Esquerdo
- (NL) Linksgestuurde Versies
- (GR) ΔΕΞΙΟΤΙΜΟΝΟ
- (日) 左ハンドル
- (SU) Автомобиль с левым рулем
- (国語) 左座驾驶

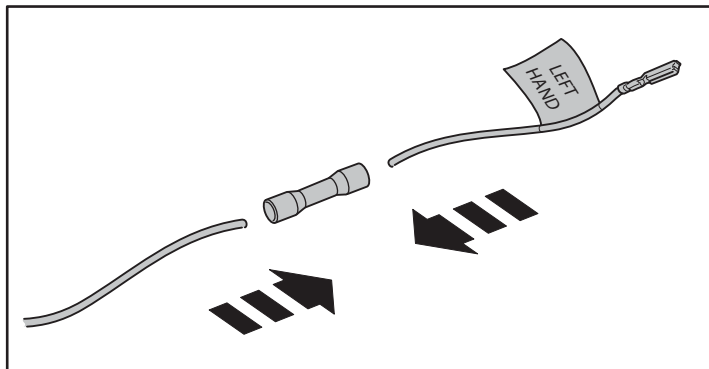

191

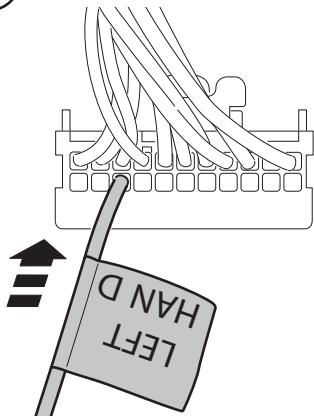

- (GB) Green / Yellow
- (D) Grün / Gelb
- (F) Vert / Jaune
- (I) Verde / Giallo
- (E) Verde / Amarillo
- (P) Verde / Amarelo
- (NL) Groen / Geel
- (GR) Πράσινο / Κίτρινο
- (日) イエロー/グリーン
- (SU) Зеленый / желтый
- (国語) 緑色/黄色

192

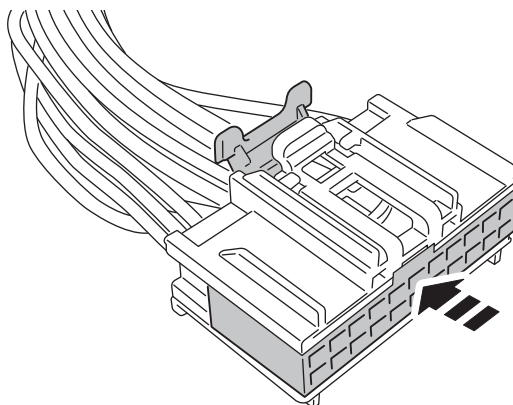

193

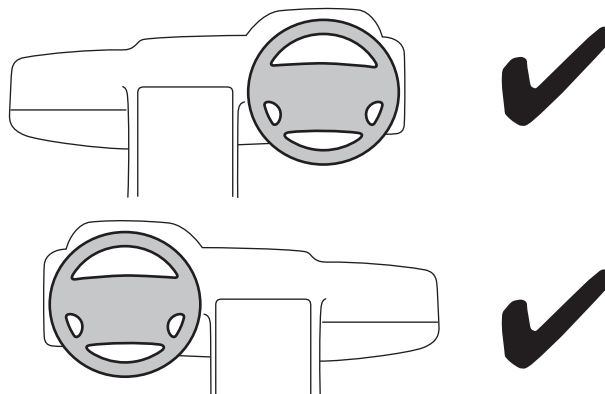
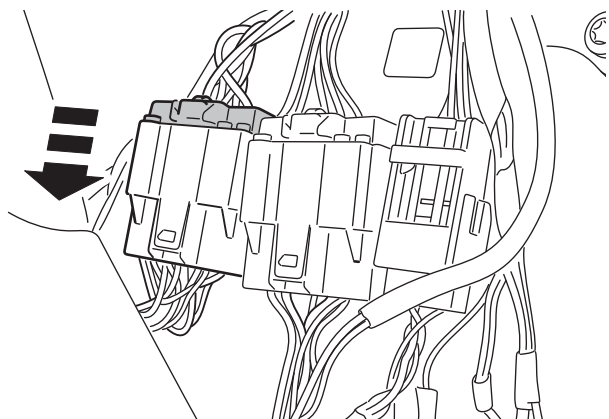

194

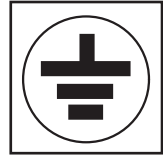
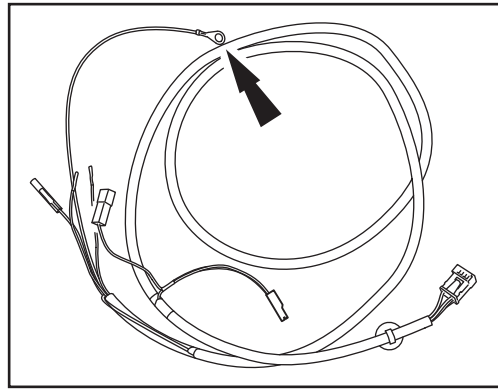
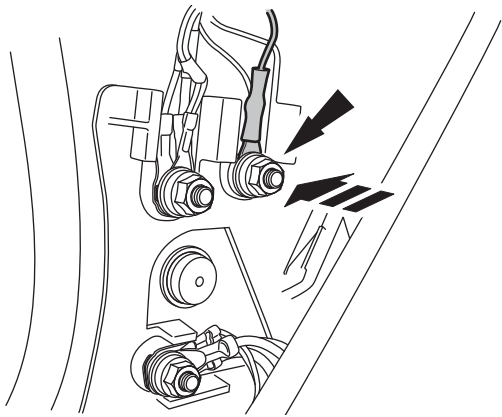

195

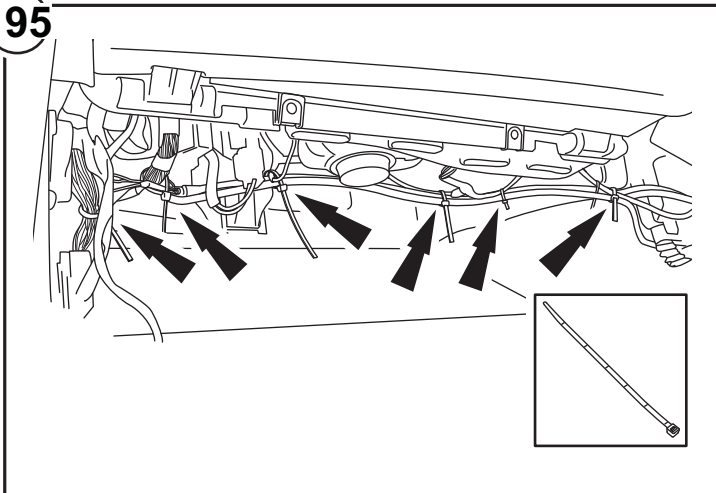

196

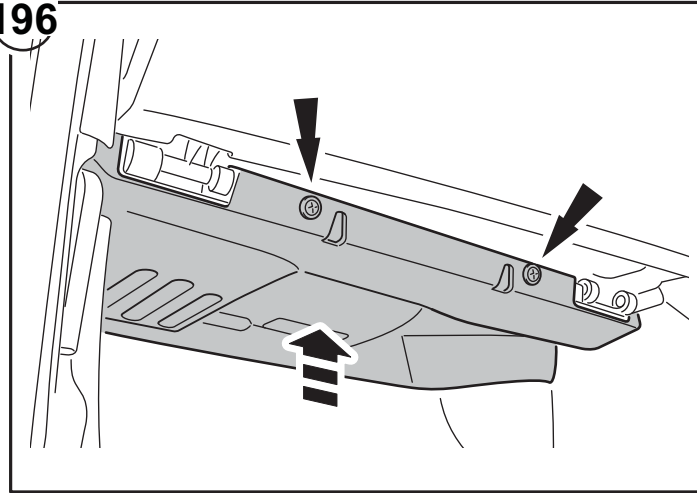

197

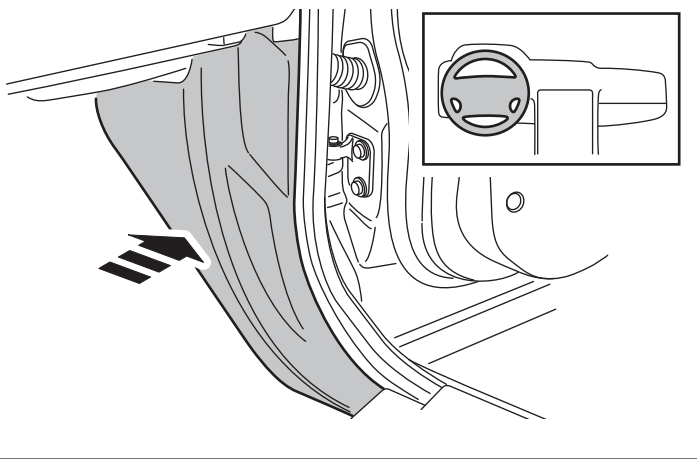
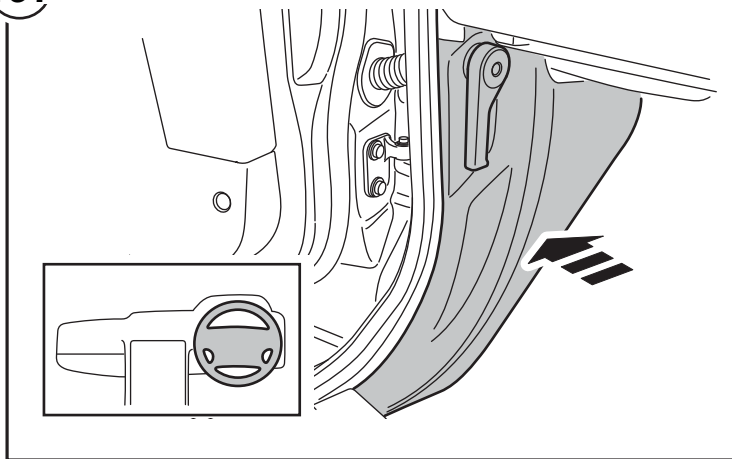

198

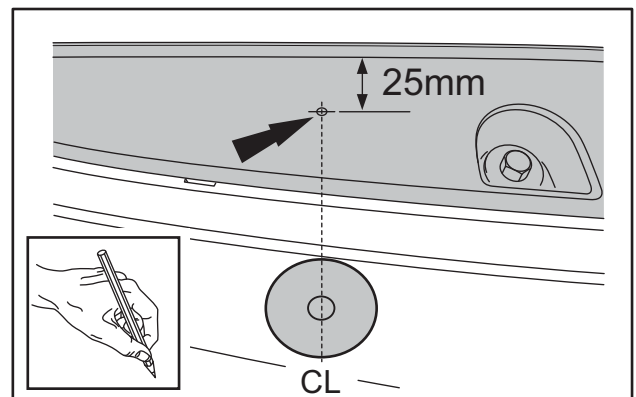
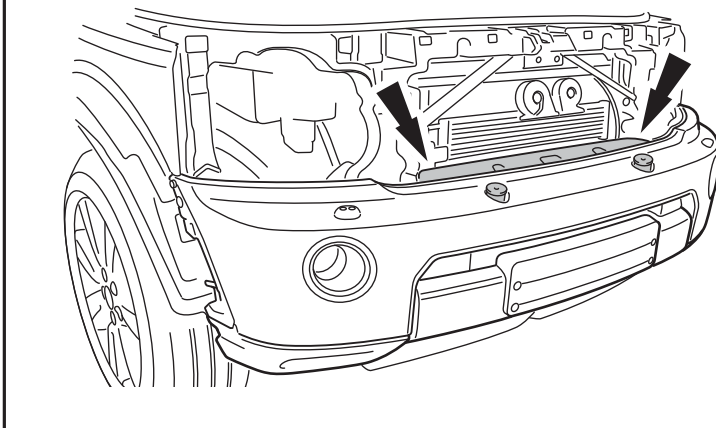

199

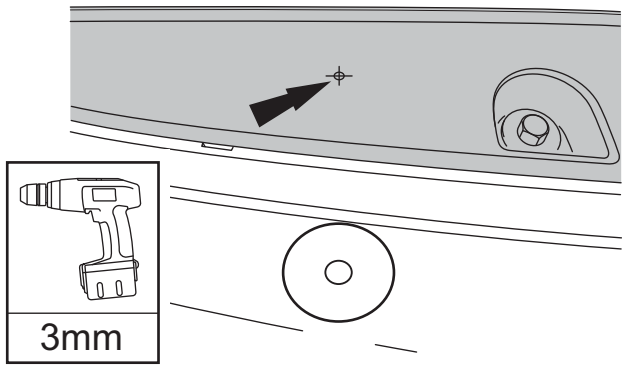

200

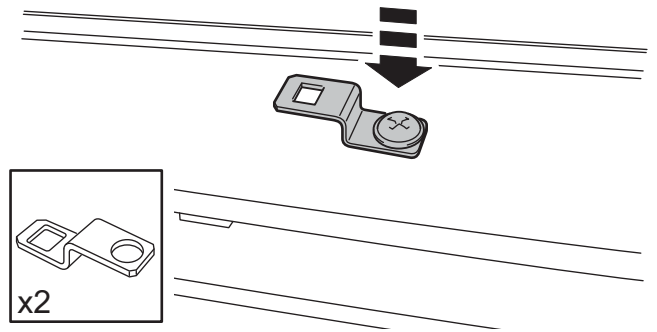

201

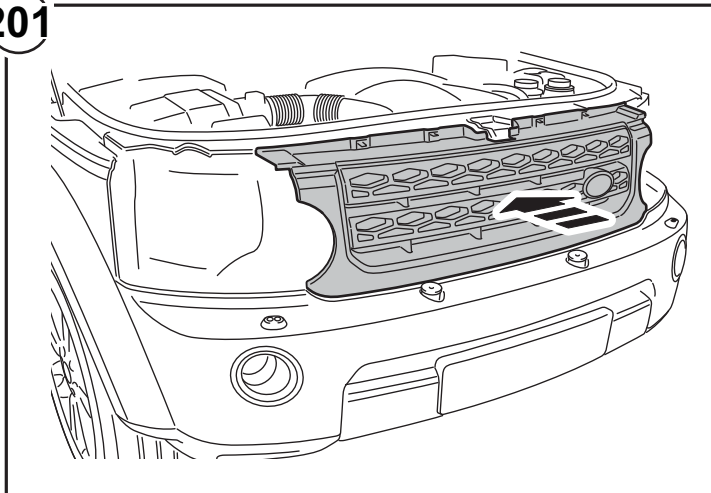

202

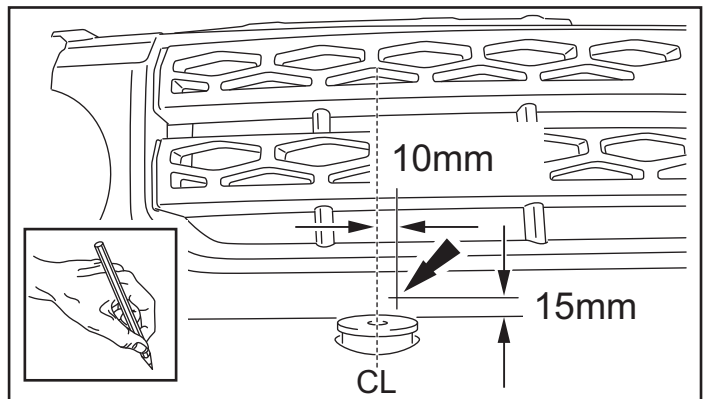
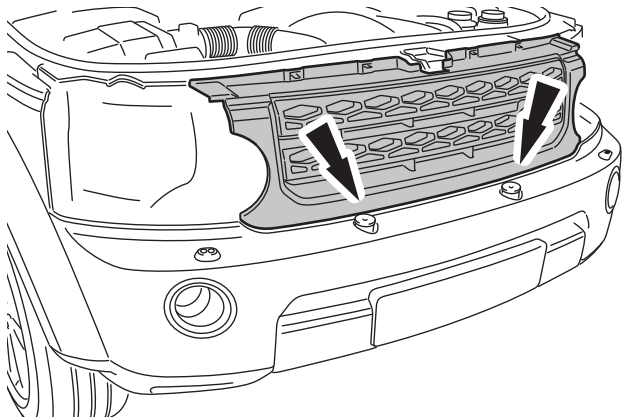

203

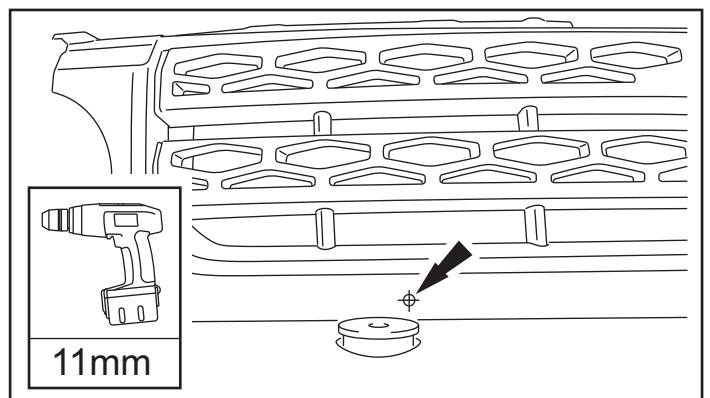
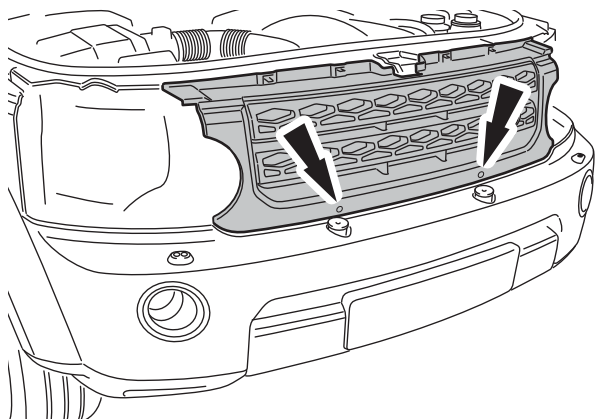

204

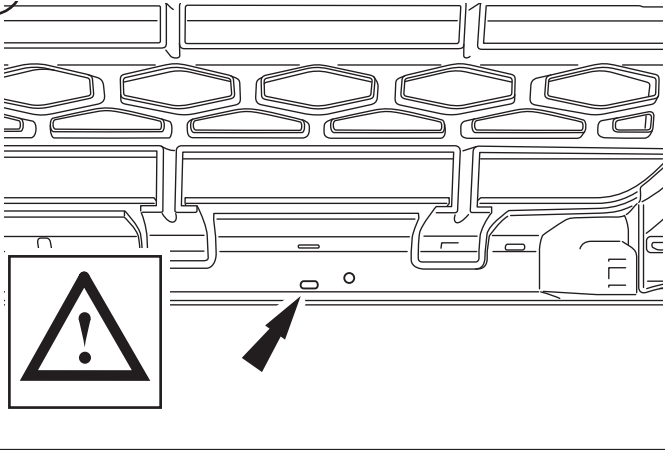

205

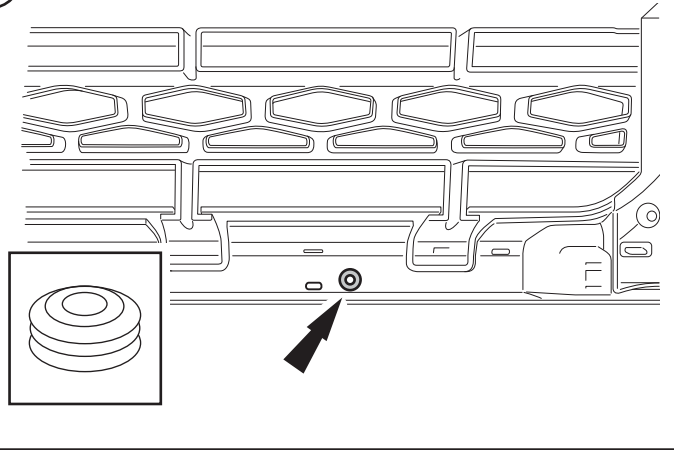

206

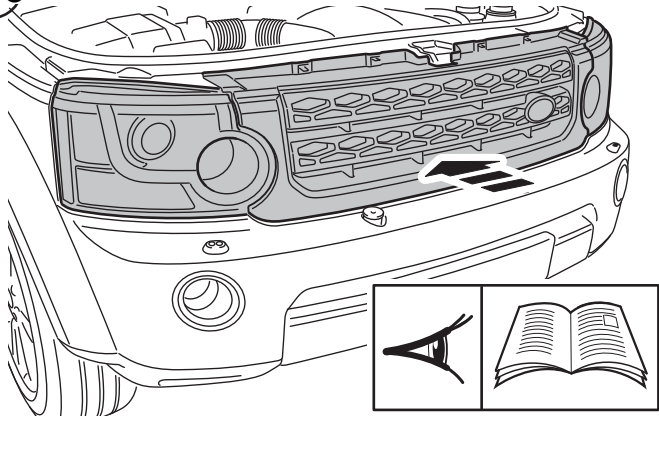

207

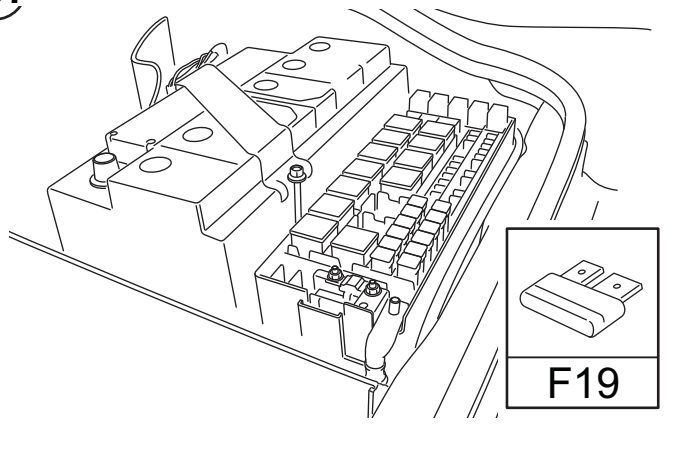

208

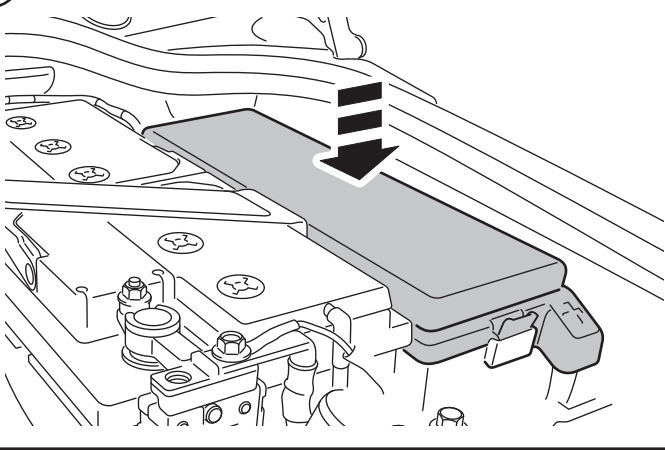

209

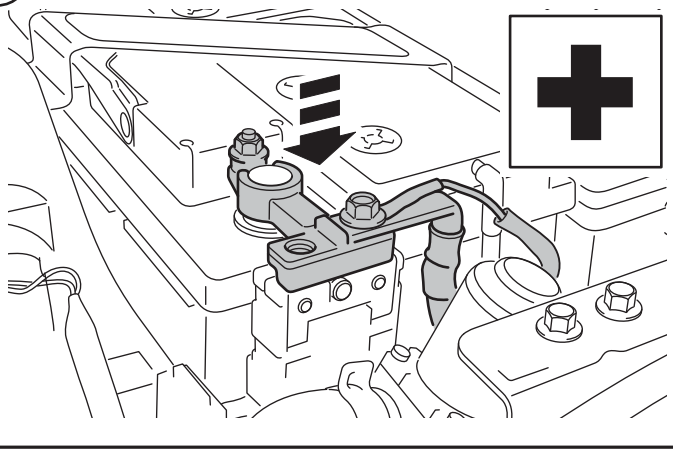

210

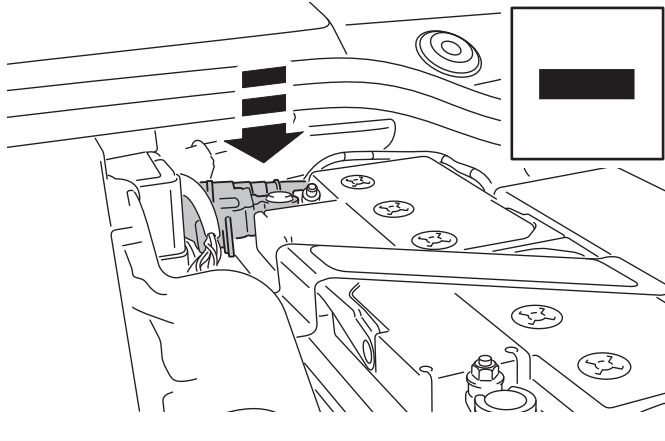

211

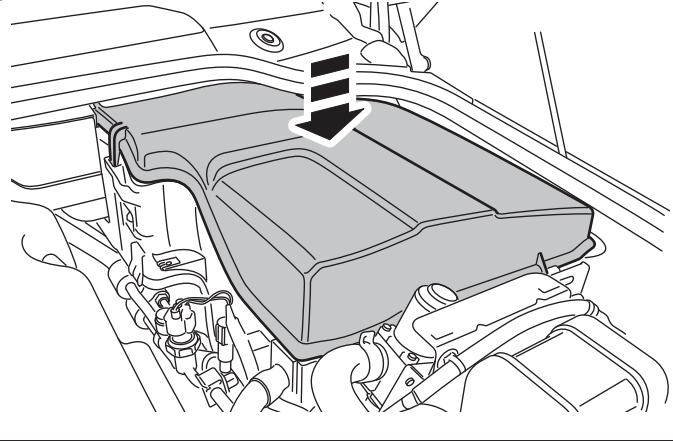

212

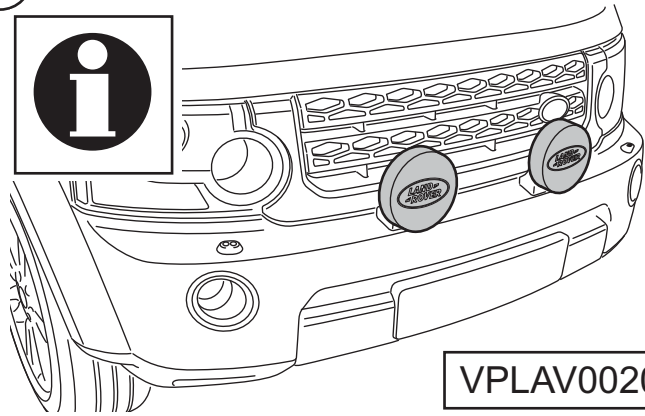

VPLAV0020

213

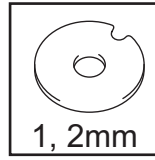

1, 2mm

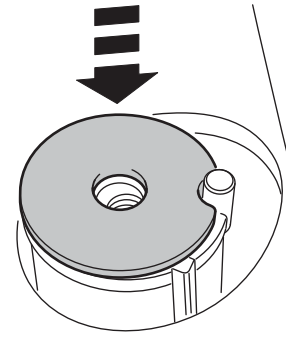

214

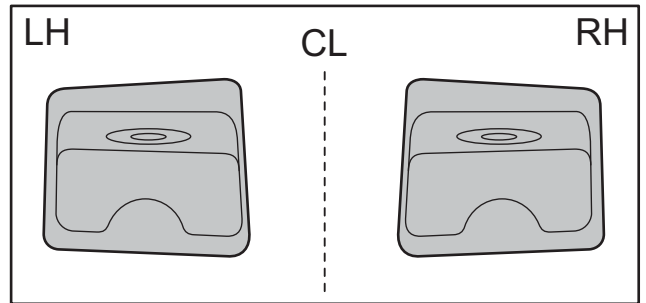
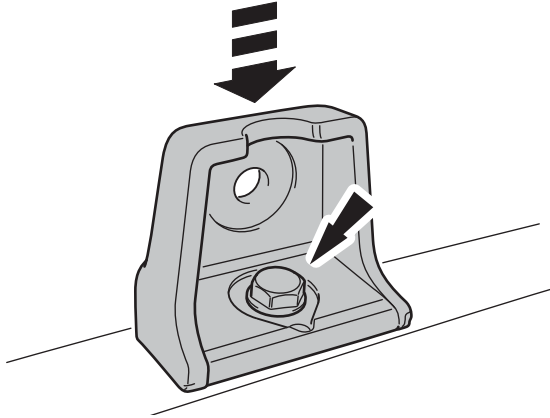
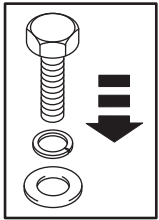

215

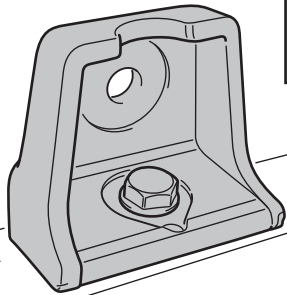

216

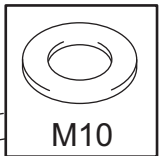
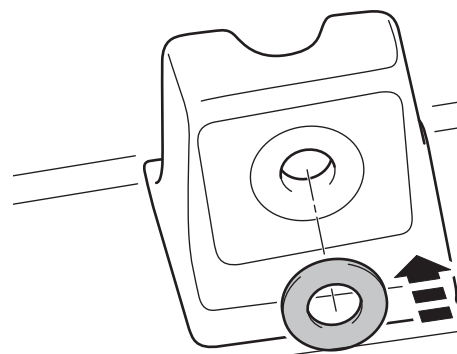

M10

217

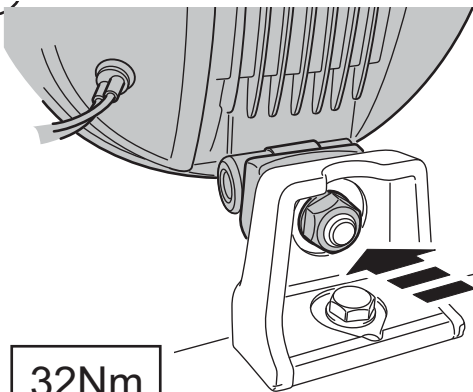

32Nm

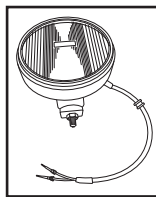

218

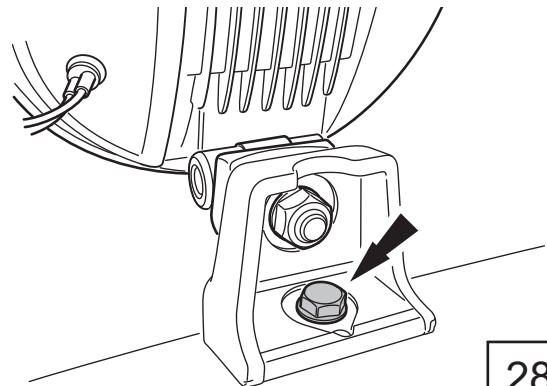

28Nm

219

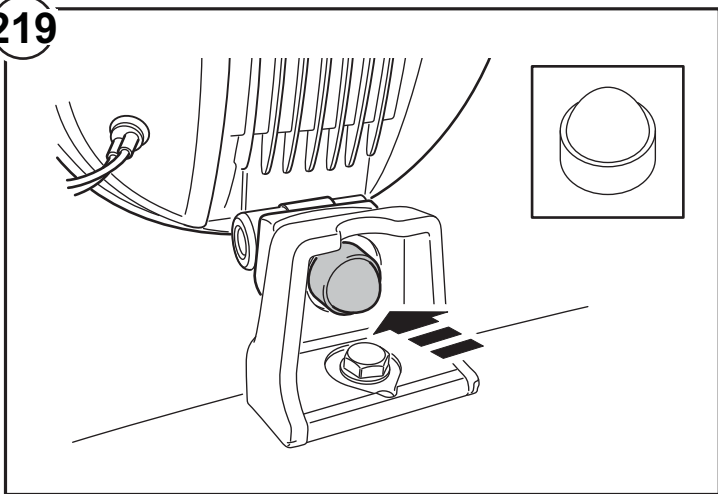

220

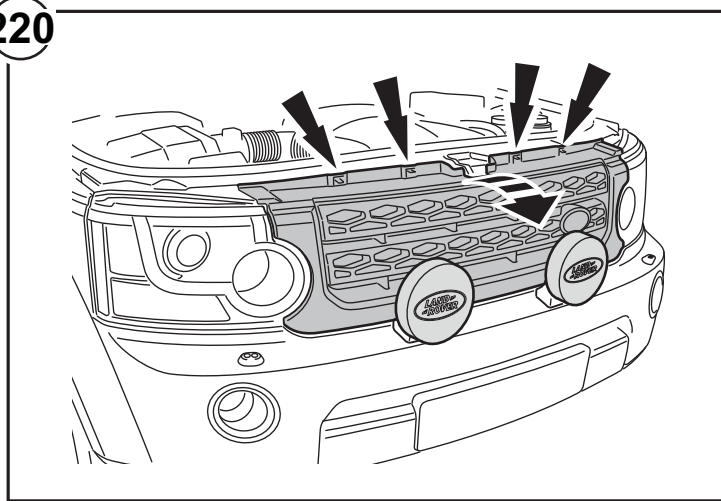

221

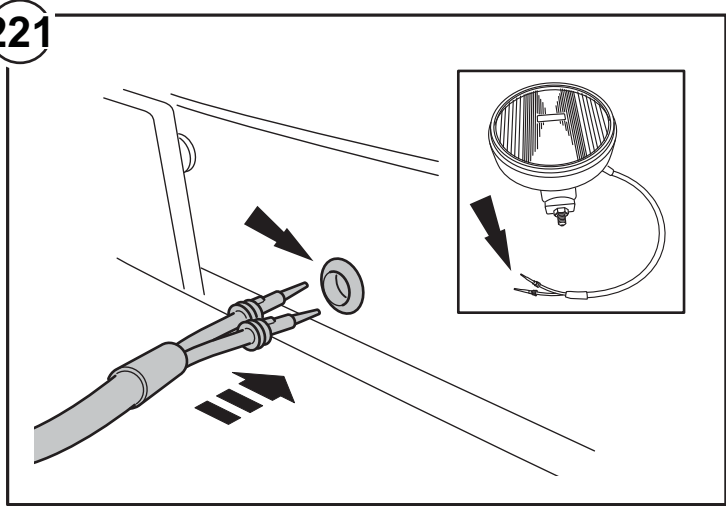

222

<p>1</p> <ul style="list-style-type: none"> (GB) White (D) Blanc (F) Blanc (I) Bianco (E) Blanco (P) Branco (NL) Wit (GR) Ασπρο (日) ホワイト (SU) Белый (国語) 白色 	<p>2</p> <ul style="list-style-type: none"> (GB) Black (D) Schwarz (F) Noir (I) Nero (E) Negro (P) Preta (NL) Zwart (GR) Μαυρο (日) ブラック (SU) Черный (国語) 黑色
---	---

223

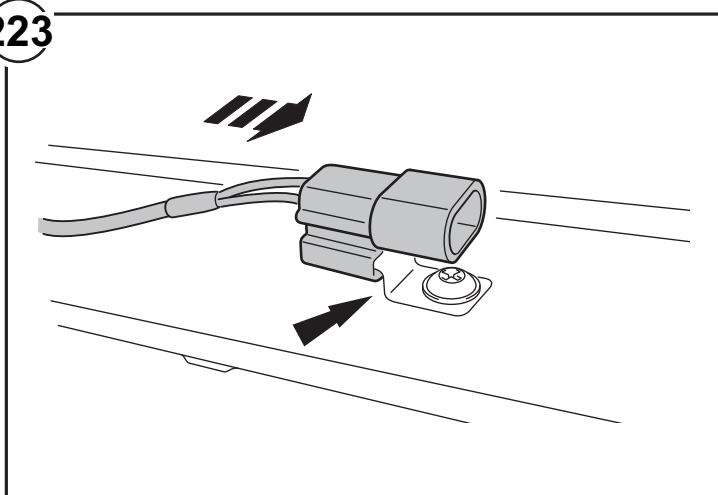

224

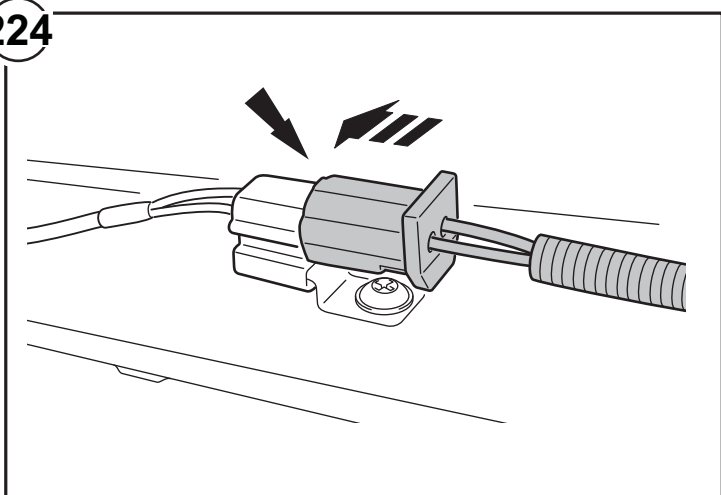

225

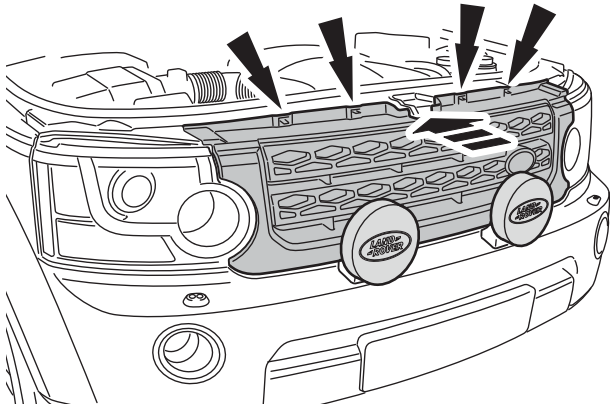

226

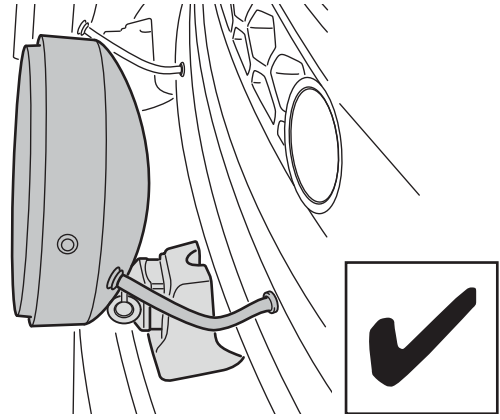

227

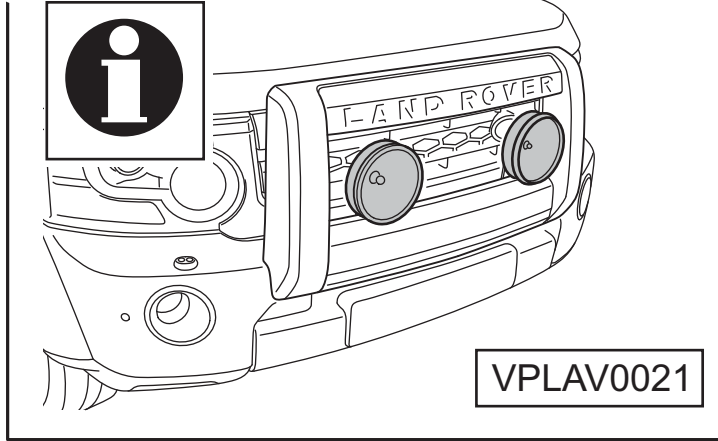

228

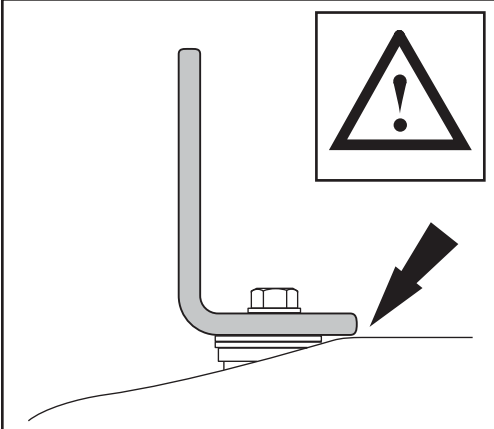
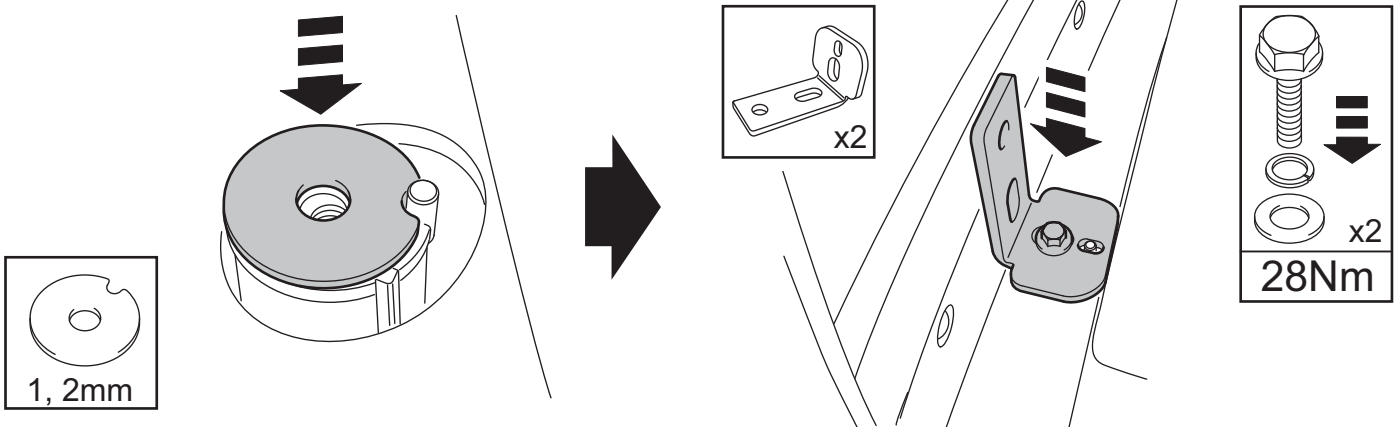

229

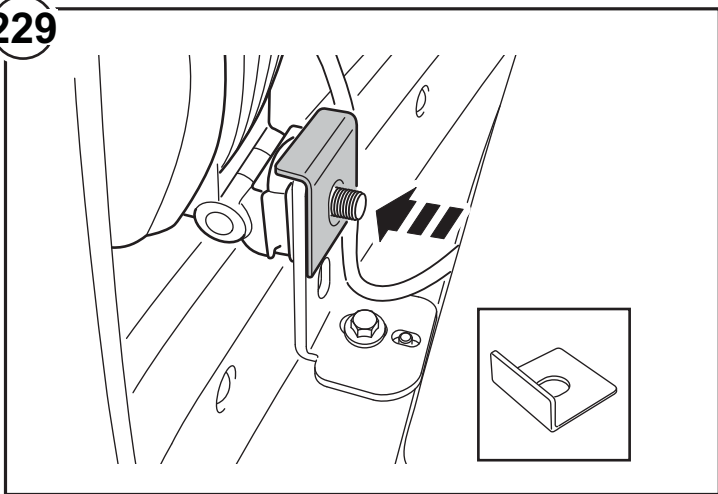

230

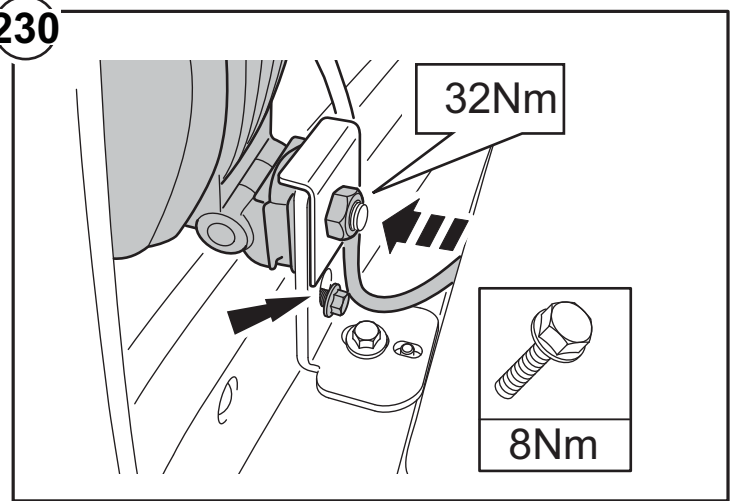

231

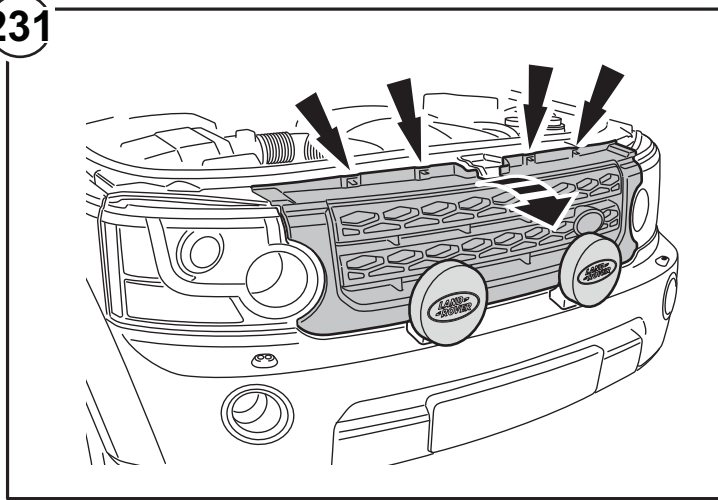

232

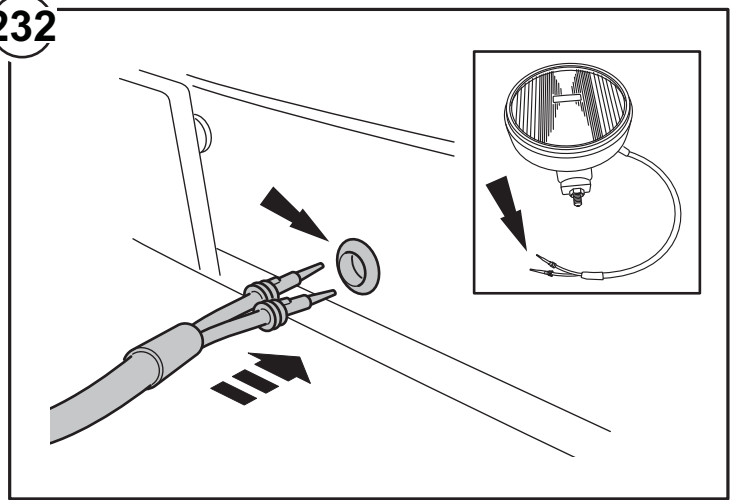

233

<p>1</p> <ul style="list-style-type: none"> (GB) White (D) Blanc (F) Blanc (I) Bianco (E) Blanco (P) Branco (NL) Wit (GR) Ασπρο (日) ホワイト (SU) Белый (国語) 白色 	<p>2</p> <ul style="list-style-type: none"> (GB) Black (D) Schwarz (F) Noir (I) Nero (E) Negro (P) Preta (NL) Zwart (GR) Μαυρο (日) ブラック (SU) Черный (国語) 黑色
---	---

234

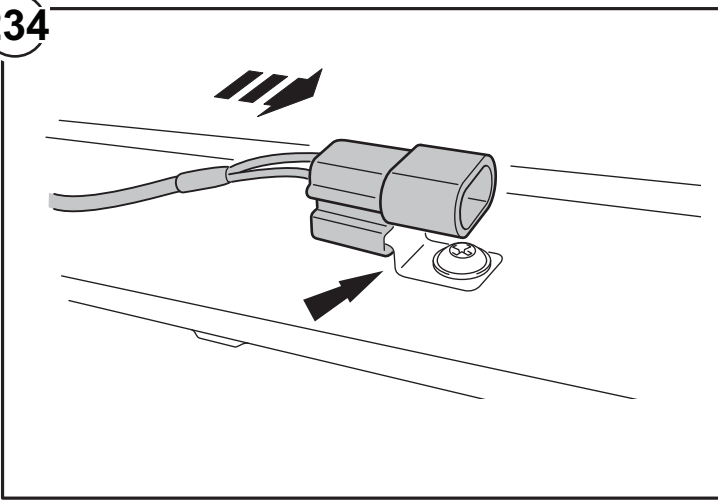

235

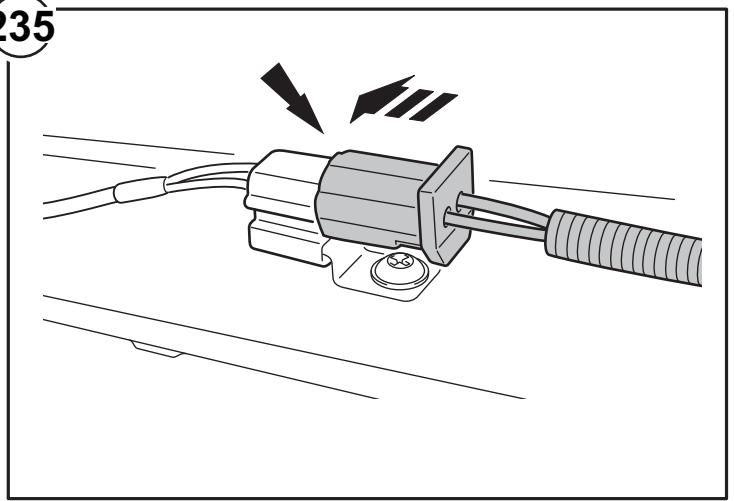

236

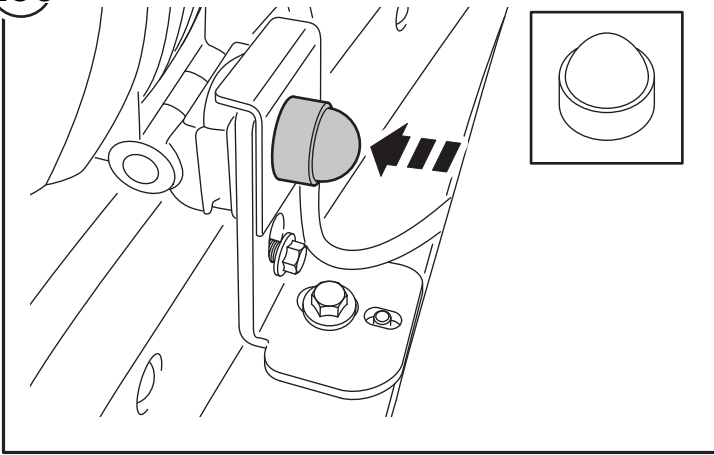

237

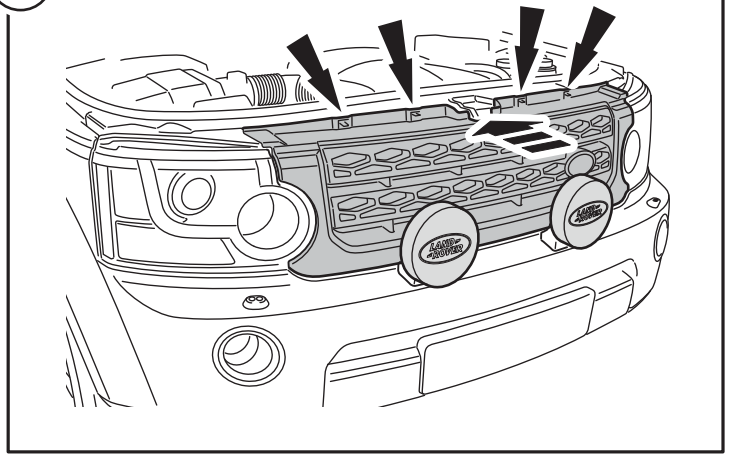

238

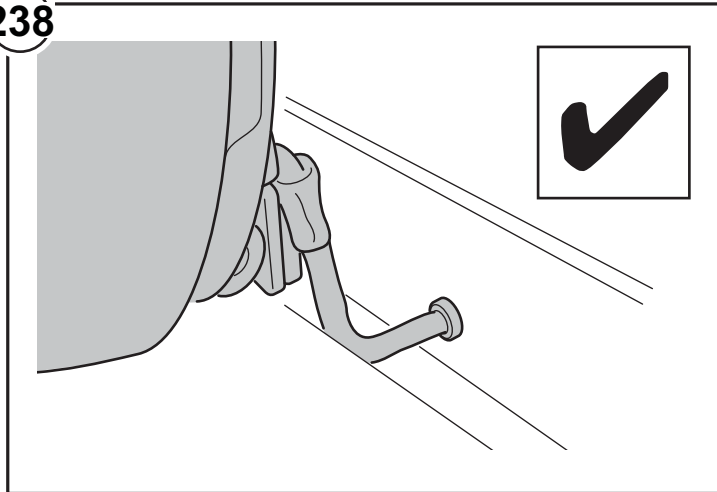

239

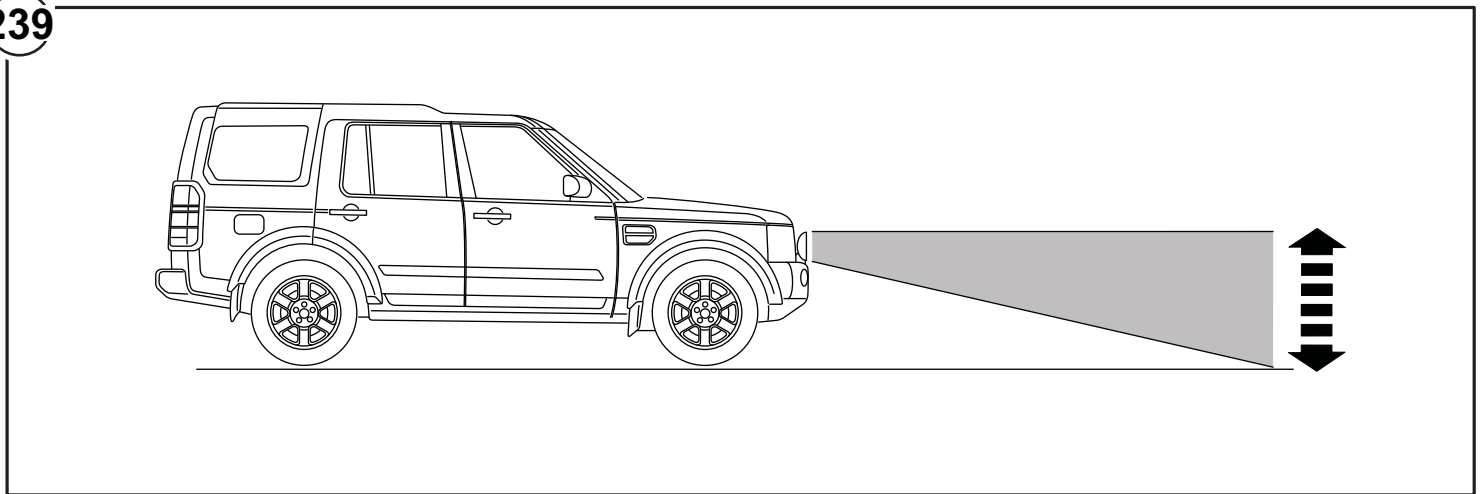

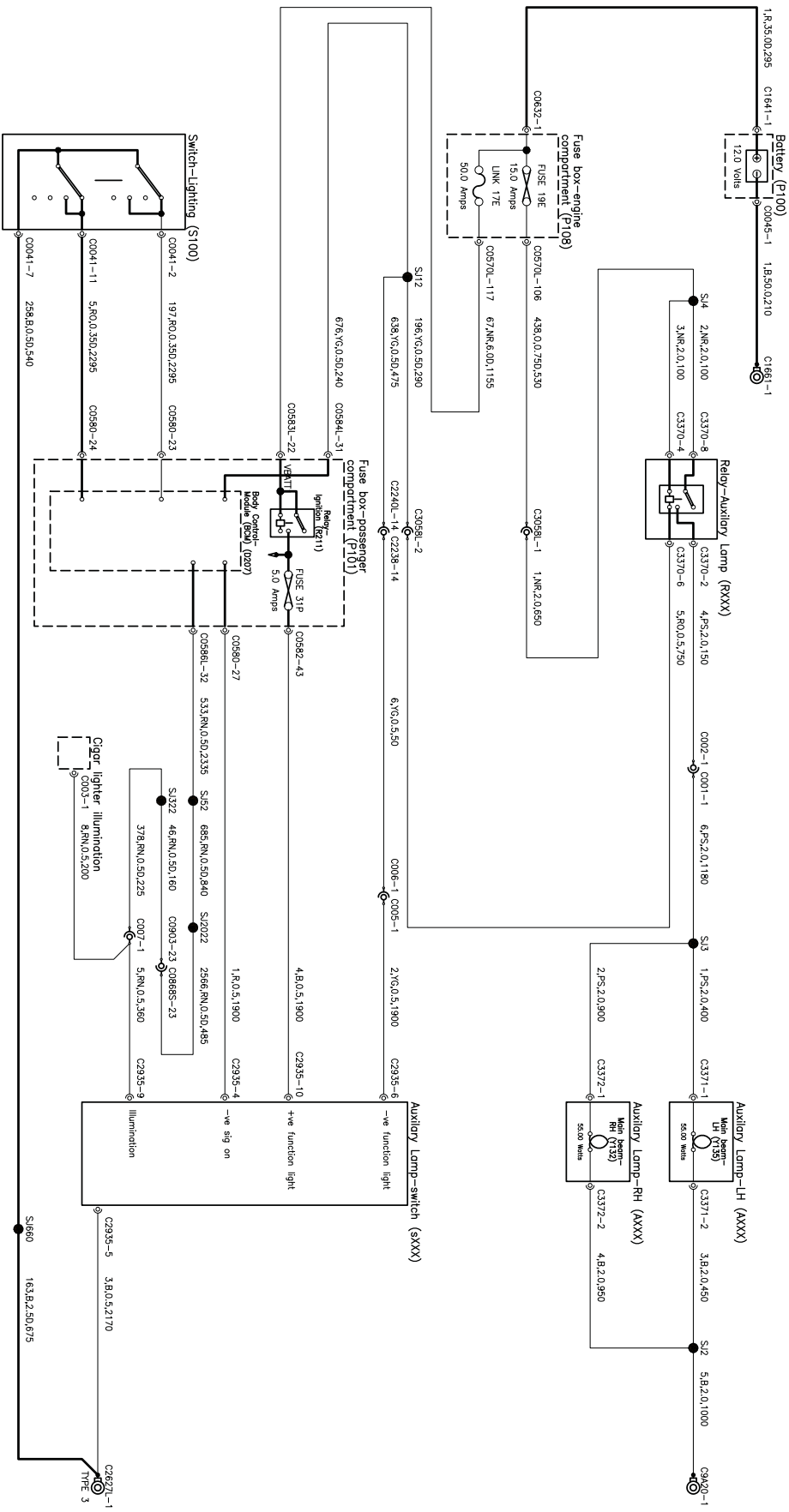

DESIGNED BY AHOOD	DATE 09-12-07	SYSTEM SUB SYSTEM	PROJECT L319-10MW JOB1P90	DATE XX.XX.XX
DESIGNED BY SYSTEM NUMBER	DATE DATE	SYSTEM MAIN UNIT	PROJECT AH22-70060-L	DATE A
DESIGNED BY SECTION NUMBER	DATE DATE	SYSTEM SYSTEM NUMBER	PROJECT 23-JUN-09	DATE 11:20