

# LAND ROVER



## Discovery Sport

**Tow Bar - Bolt On Ball / Detachable - 7 Seat - With Spare Wheel**

### *FITTING INSTRUCTION*

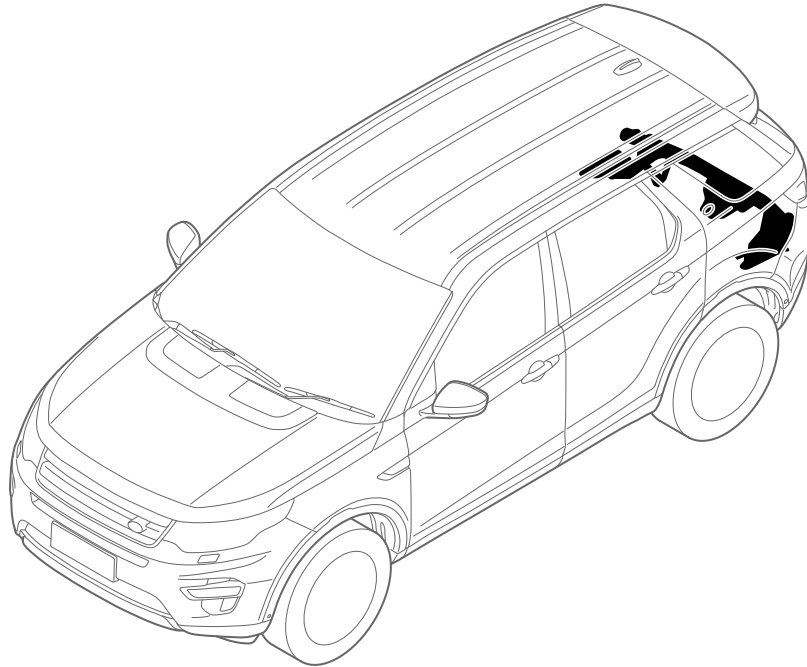

安装说明

拖车杆 - 球螺栓固定式/可拆卸 - 7座 - 带备胎

*EINBAUANLEITUNG*

Anhängerkupplung – anschraubbare Kugel/abnehmbar – 7 Sitze – mit Ersatzrad

*INSTRUCTION DE MONTAGE*

Barre de remorquage - Boulonnée sur boule / Amovible - 7 places - Avec roue de secours

*ISTRUZIONI PER L'USO*

Gancio di traino - Bolt On Ball / Removibile - 7 posti - Con ruota di scorta

*INSTRUCCION DE MONTAJE*

Barra de remolque - Atornillable en bola / Desmontable - 7 asientos - Con rueda de repuesto

*INSTRUÇÕES DE MONTAGEM*

Barra de reboque - aparafusada à esfera / destacável - 7 lugares - com roda sobresselente

*Инструкции по установке*

Буксировочный брус - болтовое крепление / съёмный - 7 мест - с запасным колесом

*MONTAGEHANDLEIDING*

Trekhaak - Bolt On Ball / Afneembaar - 7 Zitplaatsen - Met Reservewiel

取付用マニュアル

牽引バー - ボルトオンボール / 取り外し可能 - 7人乗り - スペアホイール付き

설치 지침

견인 바 - 볼트 온 볼 / 분리형 - 7인승 - 스페어 휠 포함

*Instruções de instalação*

Barra de reboque - Bola aparafusada / removível - 7 lugares - Com roda sobressalente

## WARNING!

Accessories which are not properly fitted can be dangerous. Read the instructions carefully prior to fitting. Whilst fitting, comply with instructions at all times. If in doubt, contact your nearest approved dealer.

## 警告!

未恰当地安装配件将造成安全隐患。安装前,请仔细阅读说明书。安装时,请始终遵照说明书。如有疑问,请就近联系经认可的经销商。

## ACHTUNG!

Von nicht einwandfrei verstauten Gegenständen können Gefahren ausgehen. Vor dem Einbau die Anleitung sorgfältig lesen. Während des Einbaus immer die Anleitung beachten. Im Zweifelsfall einen Vertragspartner zu Rate ziehen.

## AVERTISSEMENT!

Les accessoires montés de manière incorrecte peuvent présenter un danger. Lire attentivement les instructions avant de procéder au montage. Se référer systématiquement aux instructions pendant le montage. En cas de doute, contacter le concessionnaire agréé le plus proche.

## AVVERTENZA!

Gli accessori non montati correttamente possono essere pericolosi. Leggere attentamente le istruzioni prima del montaggio. Durante il montaggio, attenersi scrupolosamente alle istruzioni. In caso di dubbi, contattare il concessionario più vicino.

## ADVERTÉNCIA!

Los accesorios que no encajen correctamente pueden ser peligrosos. Lea detenidamente las instrucciones antes de proceder al montaje. Durante el montaje, siga las instrucciones en todo momento. Si tiene alguna duda, póngase en contacto con el concesionario oficial más cercano.

## AVISO!

Os acessórios montados inadequadamente podem ser perigosos. Leia cuidadosamente as instruções antes da montagem. Durante a montagem, siga sempre as instruções. Em caso de dúvida, contacte o concessionário autorizado mais próximo.

## ВНИМАНИЕ!

Неправильно установленные аксессуары могут быть опасны. Перед установкой внимательно прочитайте инструкцию. При установке не нарушайте требования инструкции. В случае возникновения вопросов обратитесь к авторизованному дилеру.

## WAARSCHUWING!

Onjuiste gemonteerde accessoires kunnen risico's opleveren. Lees de instructies zorgvuldig door voordat u overgaat tot monteren. Houd u bij het monteren altijd aan de instructies. Neem bij twijfel contact op met de dichtstbijzijnde erkende dealer.

## 警告!

正しく取り付けられていないアクセサリは危険である。取り付ける前に、手順を注意深く読むこと。取り付け作業中は、いつでも手順書を順守すること。疑問等がある場合、近くの正規ディーラーに問い合わせること。

## 경고!

제대로 장착되지 않은 액세서리는 위험할 수 있습니다. 장착하기 전에 지침을 주의 깊게 읽으십시오. 피팅하는 동안 항상 지침을 따르십시오. 확실하지 않은 경우 가까운 승인 대리점에 문의하십시오.

## AVISO!

Acessórios mal montados podem ser perigosos. Leia atentamente as instruções antes de instalar. Durante a montagem, siga sempre as instruções. Em caso de dúvida, entre em contato com o revendedor aprovado mais próximo.

Fitting Instructions can be found at the URL below:

有关安装说明,请参见下方的 URL:

Für eine Einbauanleitung siehe untenstehende URL:

Les instructions de montage sont disponibles à l'adresse URL ci-dessous :

Le istruzioni di montaggio sono disponibili all'indirizzo URL seguente:

Las instrucciones de montaje se pueden encontrar en la siguiente URL:

As Instruções de Montagem encontram-se no seguinte URL:

Инструкции по установке приведены на веб-сайте по следующему адресу:

De montage-instructies vindt u op de onderstaande website:

該当手順については、以下の URL を参照:

피팅 지침은 아래 URL에서 확인할 수 있습니다.

As instruções de montagem podem ser encontradas no URL abaixo:

<https://accessories-instructions.jaguar.com>

<https://accessories-instructions.landrover.com>

## VPLCT0142

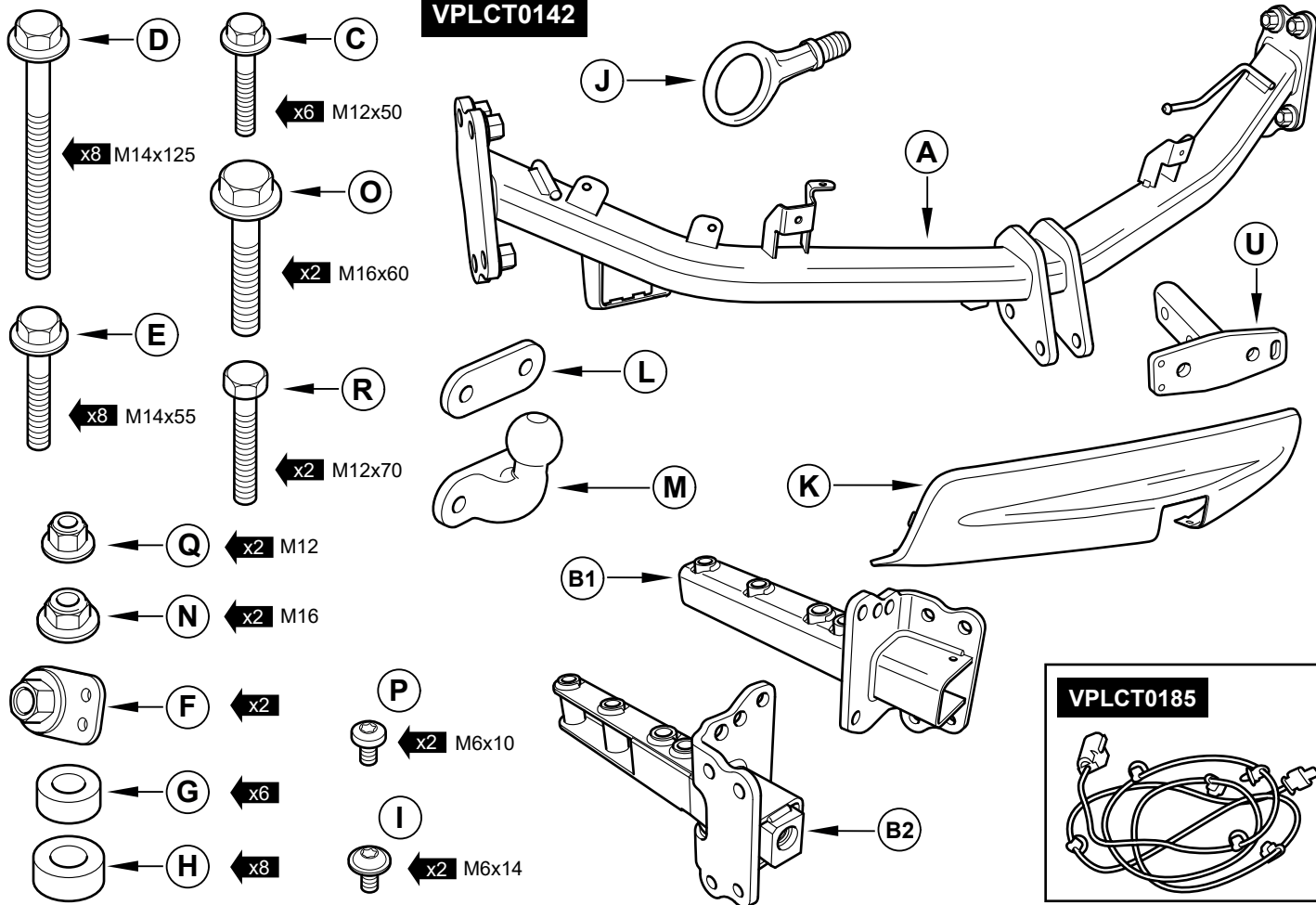

### MOTOR VEHICLE DATA

<b>Bolt On Ball</b>	
Type:	BRINK 5501
D-value:	12kN
Vertical coupling load:	145kg
Coupling class:	A50-X
Manufacturer:	Brink Towing Systems B.V.
Model application:	Land Rover Discovery Sport
EC-Type Approval No:	E11 55R-0110224
Max. Trailer Weight:	2200kg
JLR Part Number:	FK7M-F19D520-G

### 机动车数据

<b>螺栓固定球</b>	
类型:	BRINK 5501
D 值:	12千牛
垂直耦合载荷:	145公斤
耦合类:	A50-X
制造商:	Brink Towing Systems B.V.
模型应用:	Land Rover Discovery Sport
EC 型式批准号:	E11 55R-0110224
最大拖车重量:	2200公斤
JLR 零件编号:	FK7M-F19D520-G

### FAHRZEUGDATEN

<b>Anschraubbare Kugel</b>	
Typ:	BRINK 5501
D-Wert:	12kN
Vertikale Kupplungslast:	145kg
Kopplungsklasse:	A50-X
Hersteller:	Brink Towing Systems B.V.
Modellbewerbung:	Land Rover Discovery Sport
EC-Zulassungsnummer:	E11 55R-0110224
Max. Anhängergewicht:	2200kg
JLR-Teilenummer:	FK7M-F19D520-G

### DONNEES - VEHICULE AUTOMOBILE

<b>Boule à boulonner</b>	
Taper:	BRINK 5501
Valeur D :	12kN
Charge d'accouplement verticale :	145kg
Classe de couplage :	A50-X
Fabricant:	Brink Towing Systems B.V.
Modèle concerné :	Land Rover Discovery Sport
N° d'homologation type CE :	E11 55R-0110224
Poids max. de la remorque :	2200kg
Numéro de pièce JLR :	FK7M-F19D520-G

### DATI DEL VEICOLO A MOTORE

<b>Bolt On Ball</b>	
Tipo:	BRINK 5501
Valore D:	12kN
Carico accoppiamento verticale:	145kg
Classe di accoppiamento:	A50-X
Costruttore:	Brink Towing Systems B.V.
Modello applicazione:	Land Rover Discovery Sport
N. di approvazione tipo CE:	E11 55R-0110224
Max. Peso rimorchio:	2200kg
Numero parte JLR:	FK7M-F19D520-G

### DATOS DEL COCHE

<b>Bola atornillada</b>	
Tipo:	BRINK 5501
Valor D:	12kN
Carga de acoplamiento vertical:	145kg
Clase de acoplamiento:	A50-X
Fabricante:	Brink Towing Systems B.V.
Aplicación del modelo:	Land Rover Discovery Sport
Número de homologación CE:	E11 55R-0110224
Peso máximo del remolque:	2200kg
Número de pieza JLR:	FK7M-F19D520-G

### DADOS DE VEÍCULOS A MOTOR

<b>Aparafusado à bola</b>	
Tipo:	BRINK 5501
Valor D:	12kN
Carga de acoplamiento vertical:	145kg
Clase de acoplamiento:	A50-X
Fabricante:	Brink Towing Systems B.V.
Aplicação do modelo:	Land Rover Discovery Sport
Aprovação de tipo EC n.º:	E11 55R-0110224
Máx. Peso do reboque:	2200kg
Referência JLR:	FK7M-F19D520-G

### АВТОТРАНСПОРТА ДАННЫЕ

<b>Болт на шаре</b>	
Тип:	BRINK 5501
D-значение:	12kN
Вертикальная нагрузка на сцепление:	145kg
Класс сцепления:	A50-X
Производитель:	Brink Towing Systems B.V.
Модель применения:	Land Rover Discovery Sport
Номер утверждения типа EC:	E11 55R-0110224
Макс. вес прицепа:	2200kg
Номер детали JLR:	FK7M-F19D520-G

### GEGEVENS OVER MOTORVOERTUIGEN

<b>Bout-op bal:</b>	
Type:	BRINK 5501
D-waarde:	12kN
Verticale koppingsbelasting:	145kg
Koppingsklasse:	A50-X
Fabrikant:	Brink Towing Systems B.V.
Modeltoepassing:	Land Rover Discovery Sport
EG-typegoedkeuringsnummer:	E11 55R-0110224
Max. aanhangergewicht:	2200kg
JLR-onderdeelnummer:	FK7M-F19D520-G

### 自動車データ

<b>ボルトオンボール</b>	
タイプ:	BRINK 5501
D値:	12kN
直結合荷重:	145kg
カップリングクラス:	A50-X
メーカー:	Brink Towing Systems B.V.
モデルアプリケーション:	Land Rover Discovery Sport
EC型式承認番号:	E11 55R-0110224
最大トレーラー重量:	2200kg
JLR部品番号:	FK7M-F19D520-G

### 자동차 데이터

<b>볼트온볼</b>	
유형:	BRINK 5501
D-값:	12kN
수직 커플링 하중:	145kg
커플링 클래스:	A50-X
제조사:	Brink Towing Systems B.V.
모델 적용:	Land Rover Discovery Sport
EC-유형 승인 번호:	E11 55R-0110224
최대 트레일러 중량:	2200kg
JLR 부품 번호:	FK7M-F19D520-G

### DADOS DO VEÍCULO MOTORIZADO

<b>Bola de parafuso</b>	
Tipo:	BRINK 5501
Valor D:	12kN
Carga de acoplamiento vertical:	145kg
Classe de acoplamiento:	A50-X
Fabricante:	Brink Towing Systems B.V.
Aplicação modelo:	Land Rover Discovery Sport
Nº de aprovação de tipo CE:	E11 55R-0110224
Peso Máx. do Reboque:	2200kg
Número da peça JLR:	FK7M-F19D520-G

## VPLCT0185

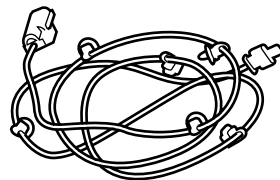

## VPLCT0148

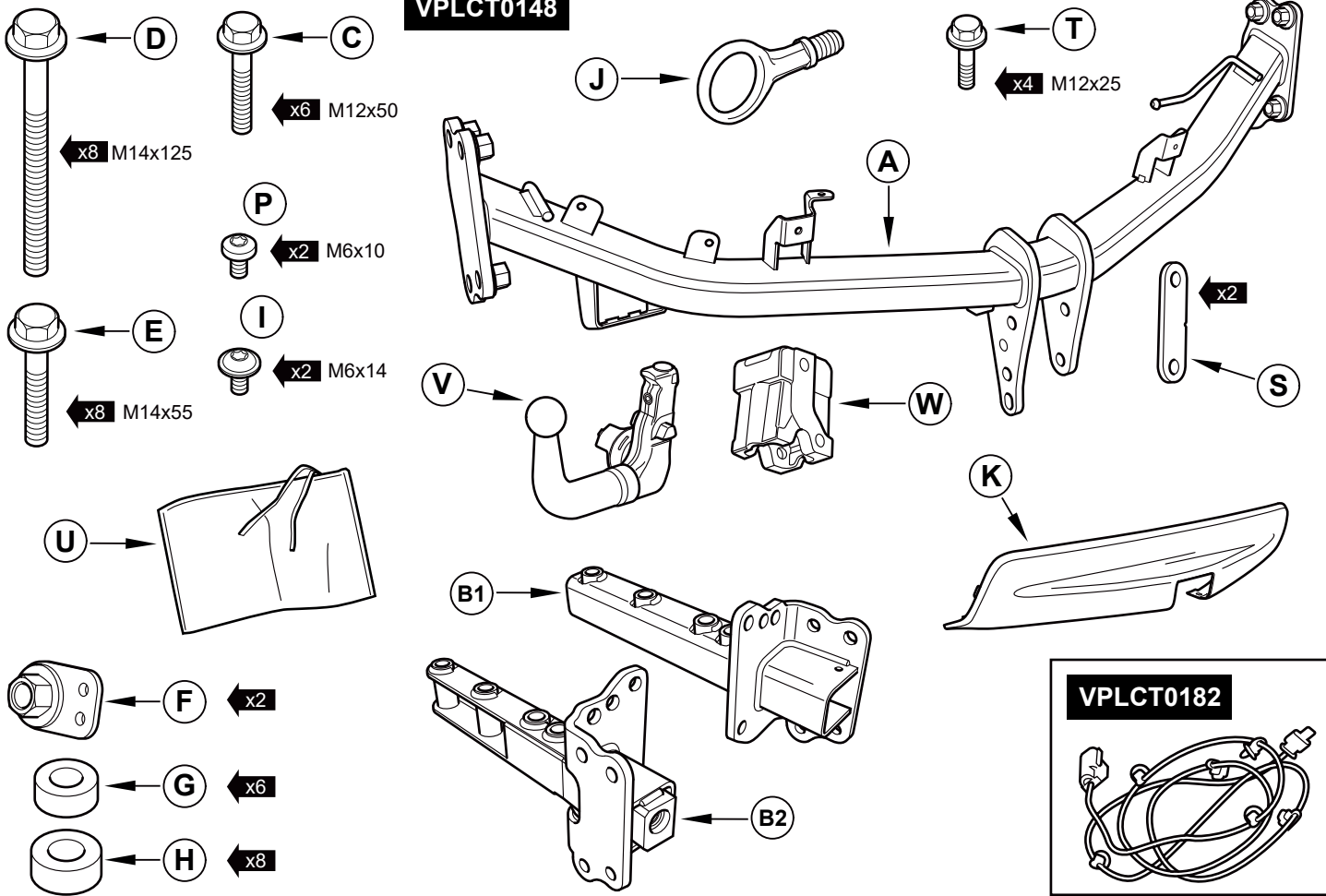

### MOTOR VEHICLE DATA

#### Towbar-Quick Release

Type:	BRINK 5488
D-value:	12kN
Vertical coupling load:	145kg
Coupling class:	A50-X
Manufacturer:	Brink Towing Systems B.V.
Model application:	Land Rover Discovery Sport
EC-Type Approval No:	E11 55R-0110223
Max. Trailer Weight:	2200kg
JLR Part Number:	FK7M-F19D520-F

### 机动车数据

牵引杆-快速释放	BRINK 5488
类型:	12千牛
D 值:	145公斤
垂直耦合载荷:	A50-X
耦合类:	Brink Towing Systems B.V.
制造商:	Land Rover Discovery Sport
模型应用:	E11 55R-0110223
EC 型式批准号:	2200公斤
最大拖车重量:	FK7M-F19D520-F
JLR 零件编号:	

### FAHRZEUGDATEN

#### Anhängerkupplung-Schnellspanner

Typ:	BRINK 5488
D-Wert:	12kN
Vertikale Kupplungslast:	145kg
Kopplungsklasse:	A50-X
Hersteller:	Brink Towing Systems B.V.
Modellbewerbung:	Land Rover Discovery Sport
EC-Zulassungsnummer:	E11 55R-0110223
Max. Anhängergewicht:	2200kg
JLR-Teilenummer:	FK7M-F19D520-F

### DONNEES - VEHICULE AUTOMOBILE

#### Barre de remorquage à démontage rapide

Taper:	BRINK 5488
Valeur D :	12kN
Charge d'accouplement verticale :	145kg
Classe de couplage :	A50-X
Fabricant:	Brink Towing Systems B.V.
Modèle concerné :	Land Rover Discovery Sport
N° d'homologation type CE :	E11 55R-0110223
Poids max. de la remorque :	2200kg
Numéro de pièce JLR :	FK7M-F19D520-F

### DATI DEL VEICOLO A MOTORE

#### Gancio di traino a sgancio rapido

Tipo:	BRINK 5488
Valore D:	12kN
Carico accoppiamento verticale:	145kg
Classe di accoppiamento:	A50-X
Costruttore:	Brink Towing Systems B.V.
Applicazione modello:	Land Rover Discovery Sport
N. di approvazione tipo CE:	E11 55R-0110223
Max. Peso rimorchio:	2200kg
Numero parte JLR:	FK7M-F19D520-F

### DATOS DEL COCHE

#### Barra de remolque de liberación rápida

Tipo:	BRINK 5488
Valor D:	12kN
Carga de acoplamiento vertical:	145kg
Clase de acoplamiento:	A50-X
Fabricante:	Brink Towing Systems B.V.
Aplicación del modelo:	Land Rover Discovery Sport
Número de homologación CE:	E11 55R-0110223
Peso máximo del remolque:	2200kg
Número de pieza JLR:	FK7M-F19D520-F

### DADOS DE VEÍCULOS A MOTOR

#### Libertação rápida da barra de reboque

Tipo:	BRINK 5488
Valor D:	12kN
Carga de acoplamiento vertical:	145kg
Classe de acoplamiento:	A50-X
Fabricante:	Brink Towing Systems B.V.
Aplicação do modelo:	Land Rover Discovery Sport
Aprovação de tipo EC n.º:	E11 55R-0110223
Máx. Peso do reboque:	2200kg
Referência JLR:	FK7M-F19D520-F

### АВТОТРАНСПОРТА ДАННЫЕ

#### Буксир-быстрое снятие

Тип:	BRINK 5488
D-значение:	12kN
Вертикальная нагрузка на сцепление:	145kg
Класс сцепления:	A50-X
Производитель:	Brink Towing Systems B.V.
Модель применения:	Land Rover Discovery Sport
Номер утверждения типа EC:	E11 55R-0110223
Макс. вес прицепа:	2200kg
Номер детали JLR:	FK7M-F19D520-F

### GEGEVENS OVER MOTORVOERTUIGEN

#### Trekhaak-Snelontgrendeling

Type:	BRINK 5488
D-waarde:	12kN
Verticale koppelingsbelasting:	145kg
Koppelingsklasse:	A50-X
Fabrikant:	Brink Towing Systems B.V.
Modeltoepassing:	Land Rover Discovery Sport
EG-typegoedkeuringsnummer:	E11 55R-0110223
Max. aanhangergewicht:	2200kg
JLR-onderdeelnummer:	FK7M-F19D520-F

### 自動車データ

トウバー-クイックリリース	BRINK 5488
タイプ:	12kN
D値:	145kg
直結合荷重:	A50-X
カップリングクラス:	Brink Towing Systems B.V.
メーカー:	Land Rover Discovery Sport
モデルアプリケーション:	E11 55R-0110223
EC型式承認番号:	2200kg
最大トレーラー重量:	FK7M-F19D520-F
JLR部品番号:	

### 자동차 데이터

견인바-퀵 릴리스	BRINK 5488
유형:	12kN
D-값:	145kg
수직 커플링 하중:	A50-X
커플링 클래스:	Brink Towing Systems B.V.
제조업체:	Land Rover Discovery Sport
모델 적용:	E11 55R-0110223
EC-유형 승인 번호:	2200kg
최대 트레일러 중량:	FK7M-F19D520-F
JLR 부품 번호:	

### DADOS DO VEÍCULO MOTORIZADO

#### Engate de reboque com libertação rápida

Tipo:	BRINK 5488
Valor D:	12kN
Carga de acoplamiento vertical:	145kg
Classe de acoplamiento:	A50-X
Fabricante:	Brink Towing Systems B.V.
Aplicação modelo:	Land Rover Discovery Sport
Nº de aprovação de tipo CE:	E11 55R-0110223
Peso Máx. do Reboque:	2200kg
Número da peça JLR:	FK7M-F19D520-F

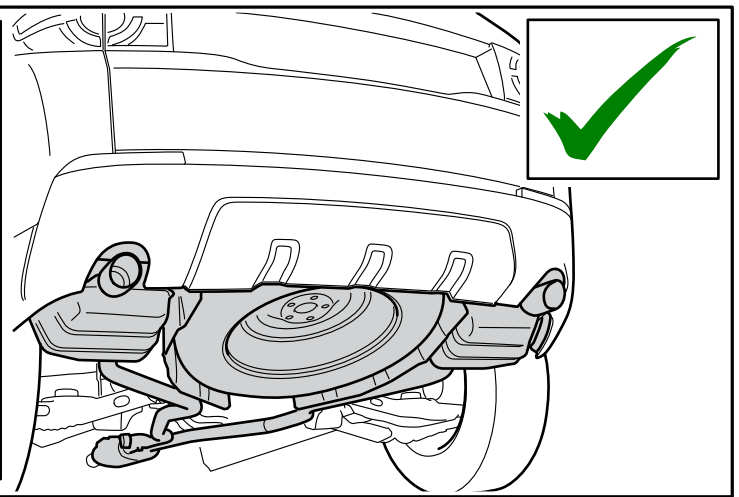
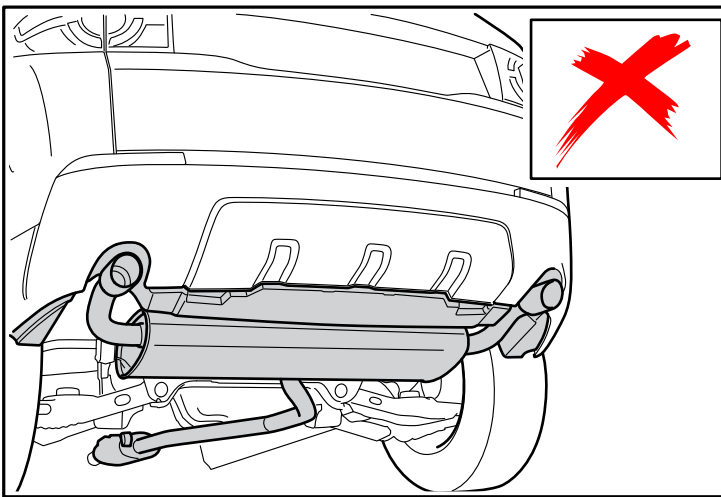

1

The following instructions are valid for both sides of the vehicle.

以下说明适用于车辆两侧。

Die folgenden Anweisungen sind für beide Fahrzeugseiten gültig.

Les instructions suivantes sont valables pour les deux côtés du véhicule.

Le seguenti istruzioni sono valide per entrambi i lati del veicolo.

Las siguientes instrucciones son válidas para ambos lados del vehículo.

As instruções seguintes são válidas para ambos os lados do veículo.

Следующие инструкции действительны для обеих сторон автомобиля.

De volgende instructies gelden voor beide zijden van het voertuig.

車両の両サイドに対して、以下の指示に従う。

다음 지침은 차량의 양쪽에 모두 적용됩니다.

As instruções a seguir são válidas para ambos os lados do veículo.

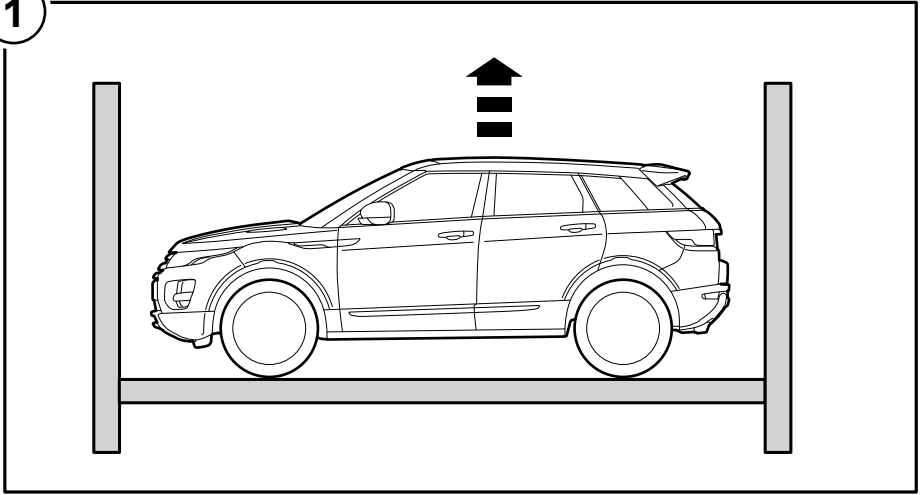

2

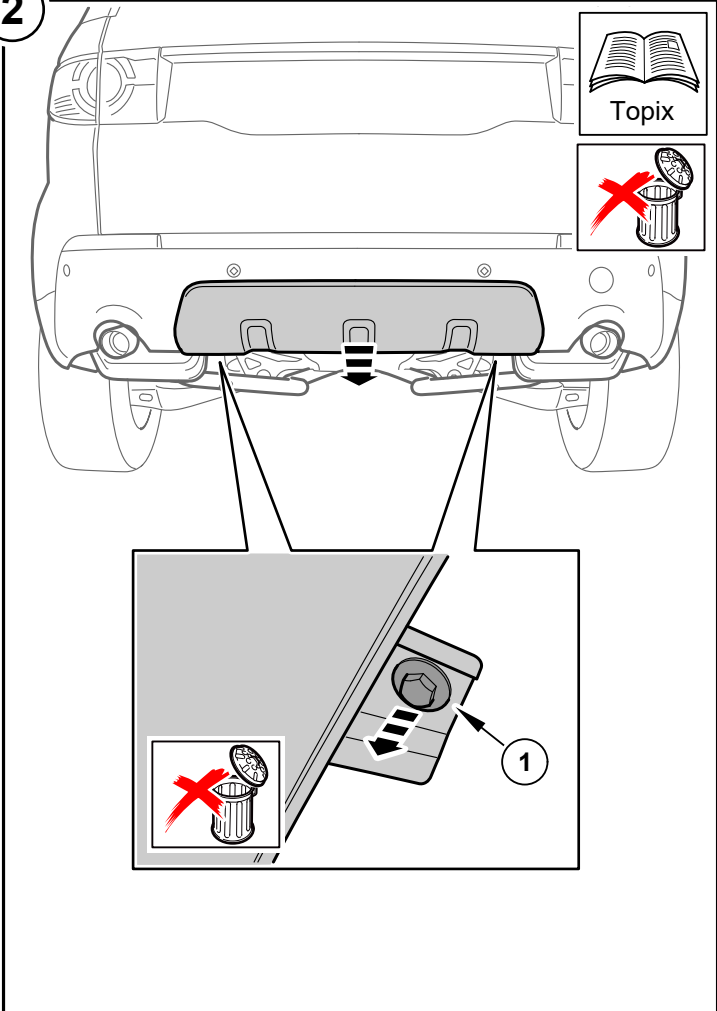

3

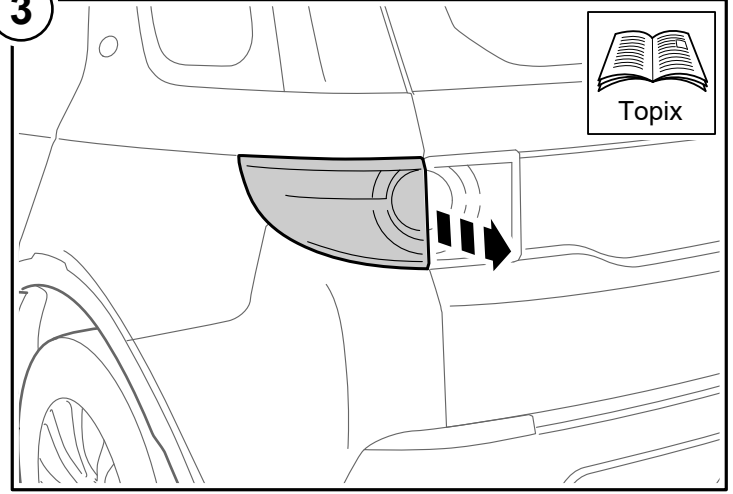

4

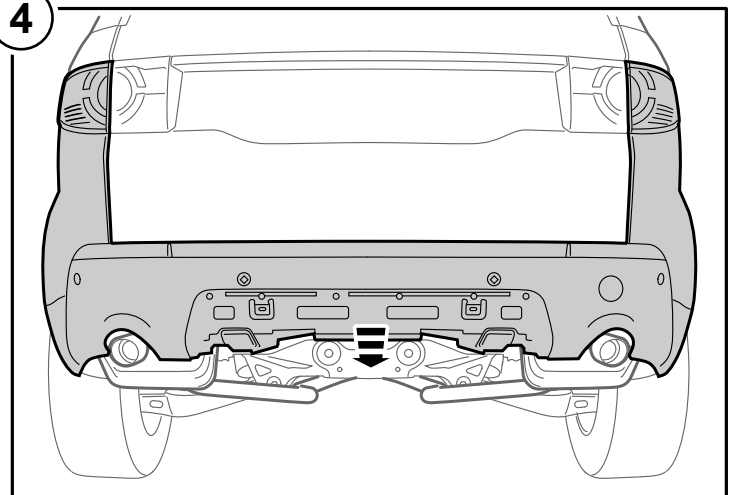

5

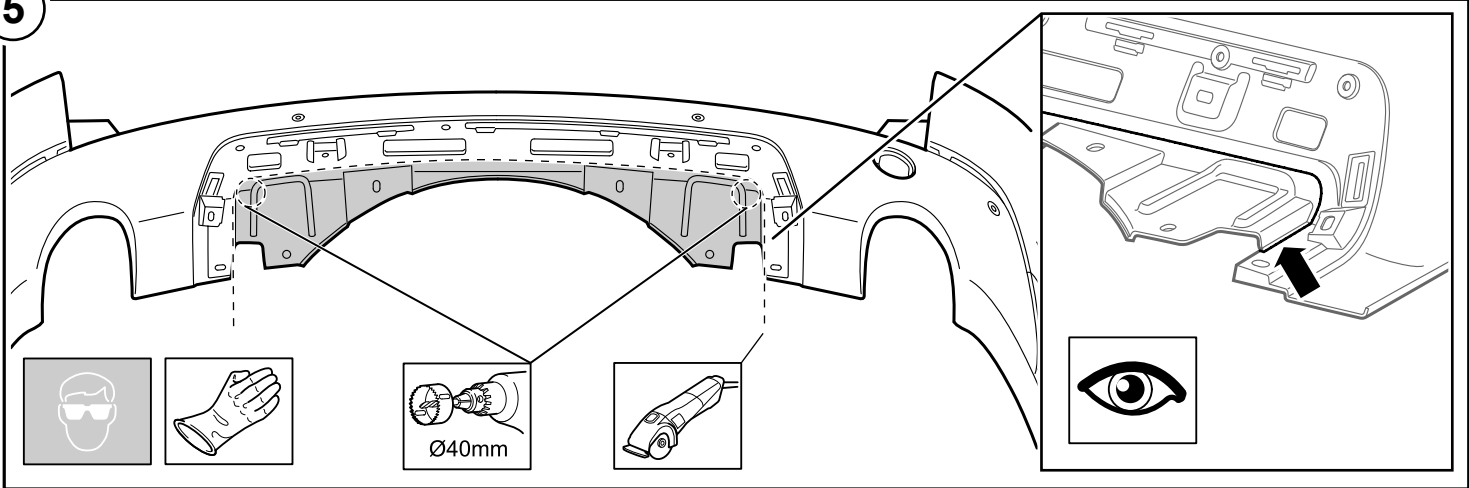

6

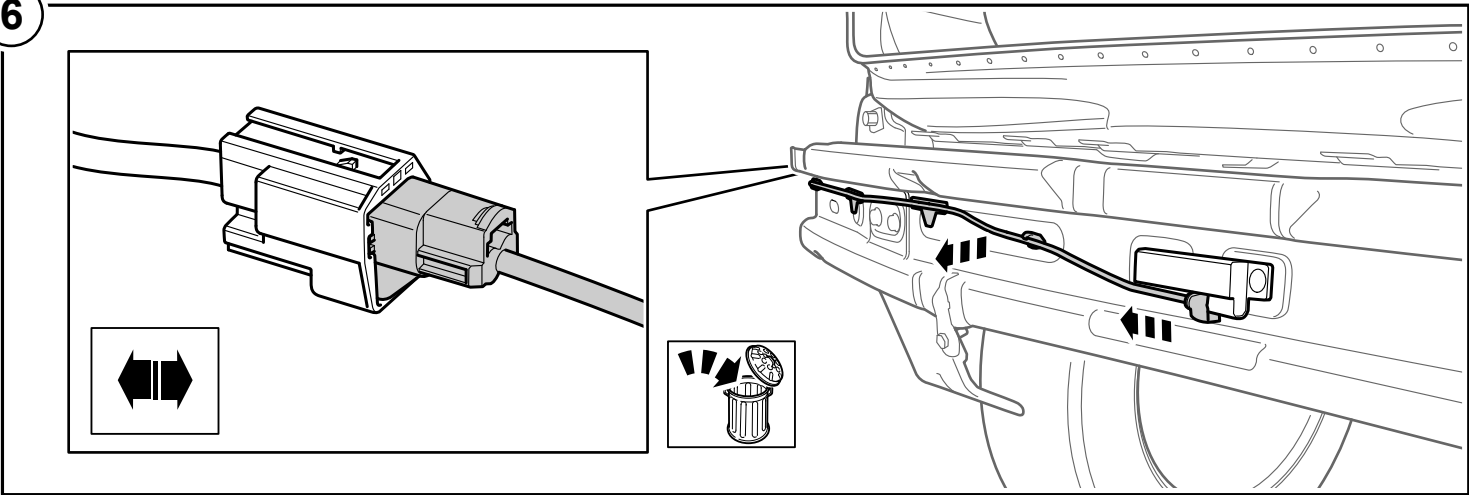

7

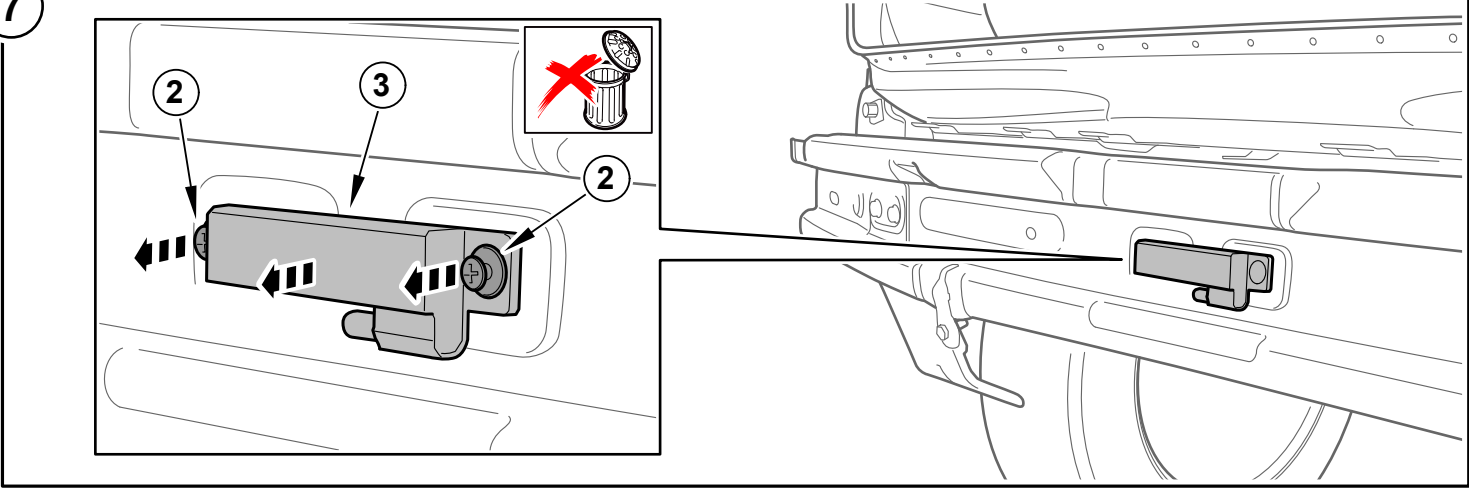

8

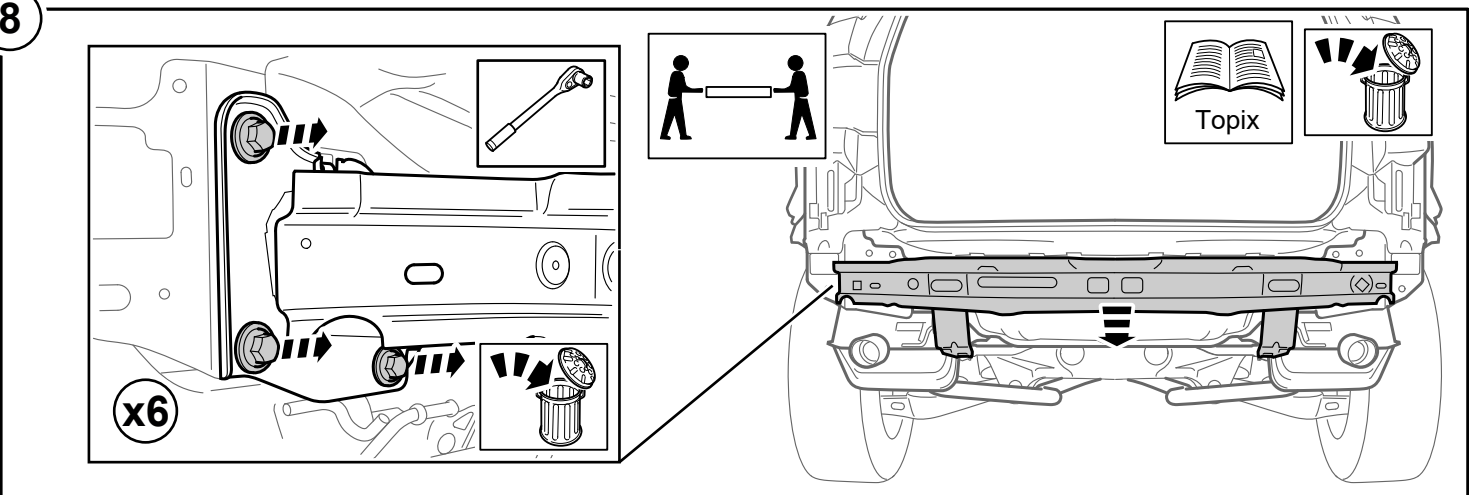

9

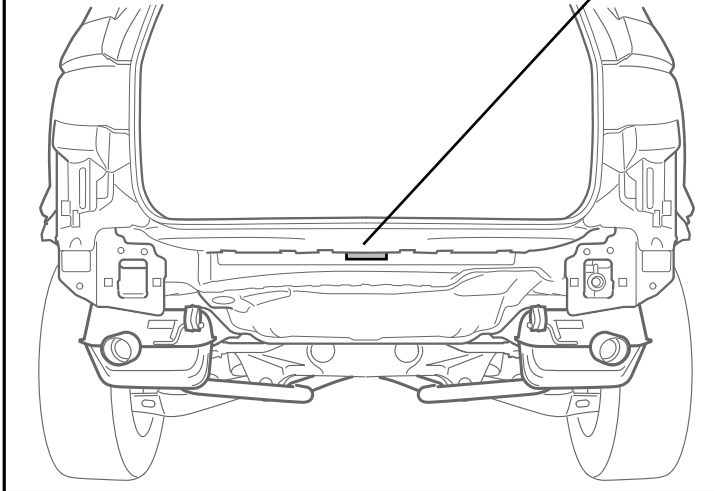
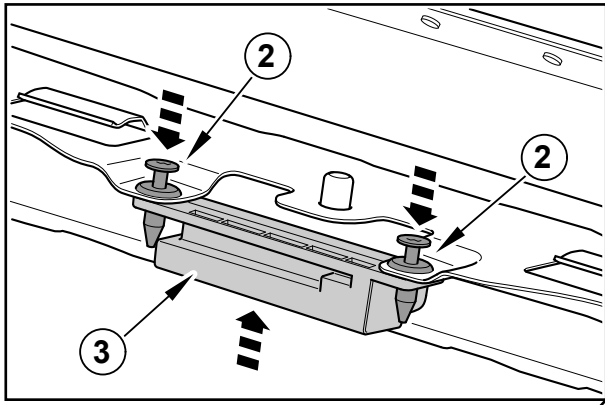

10

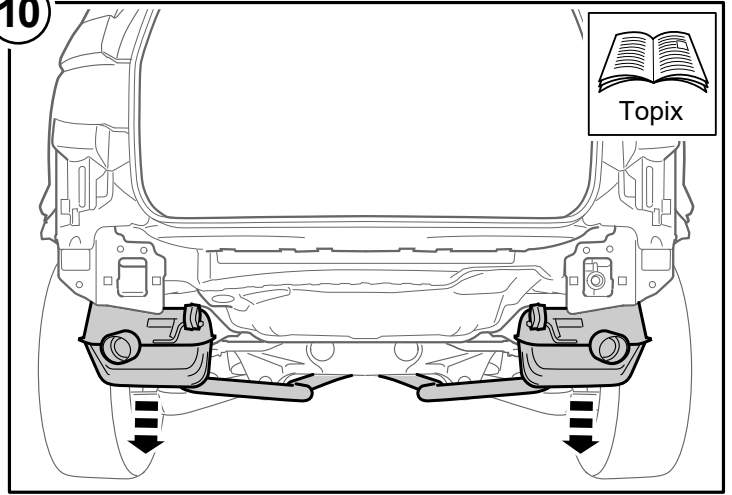

11

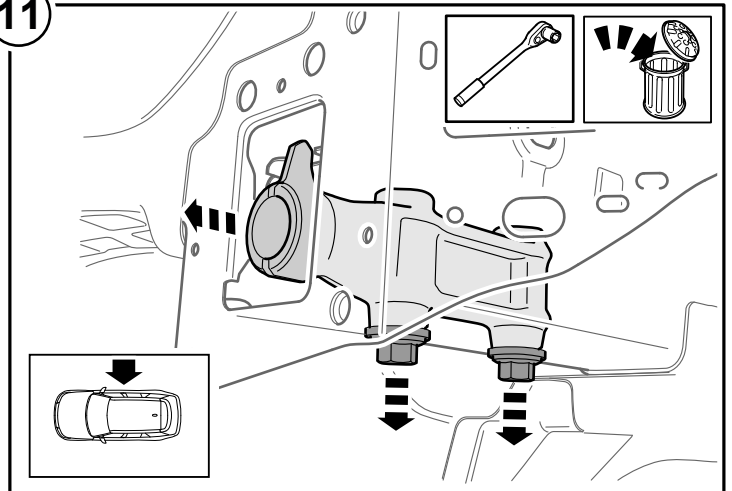

12

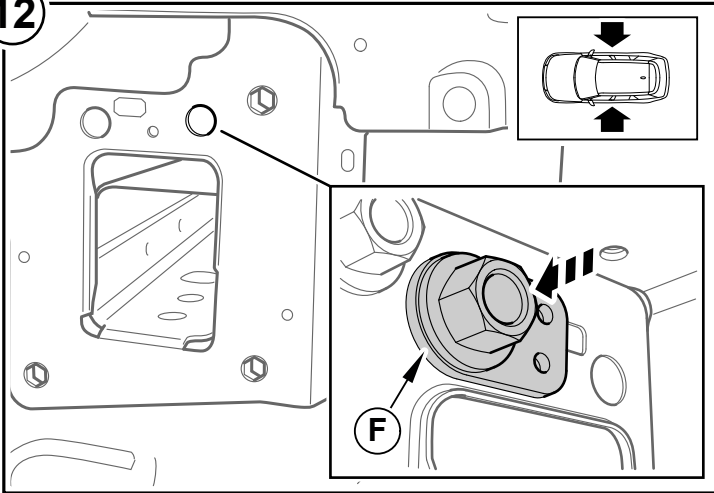

13

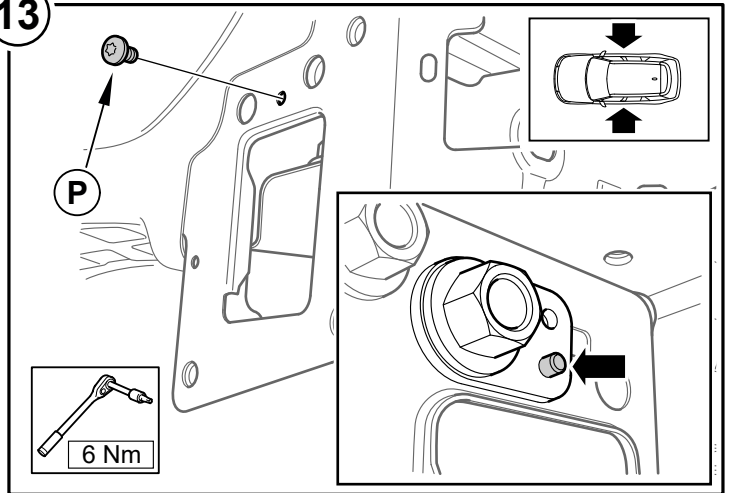

14

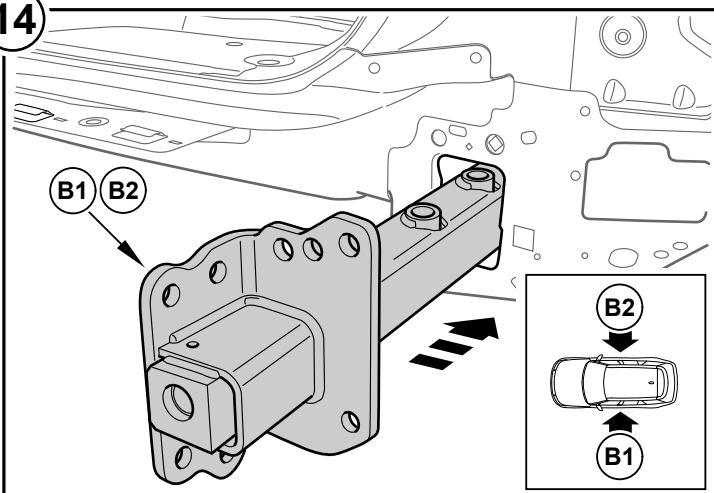

15

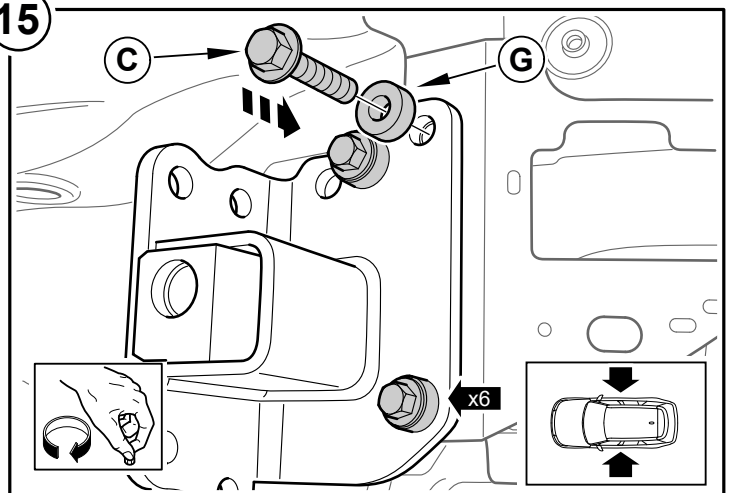

16

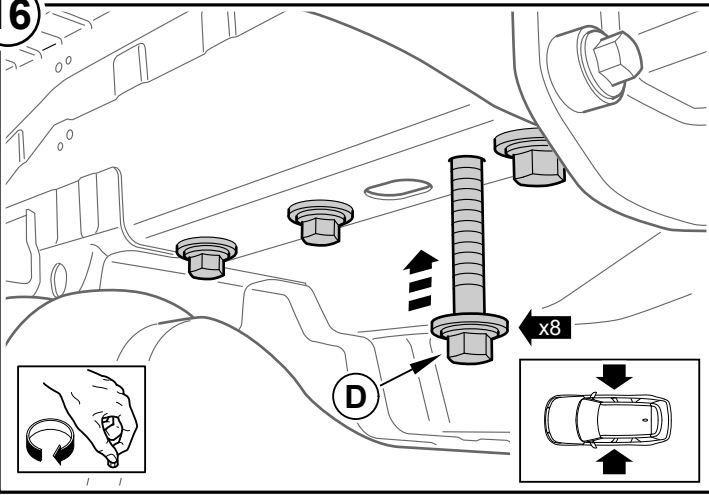

17

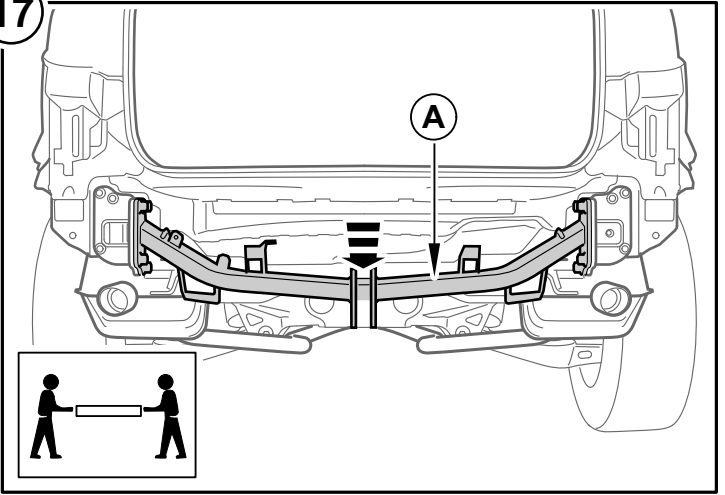

18

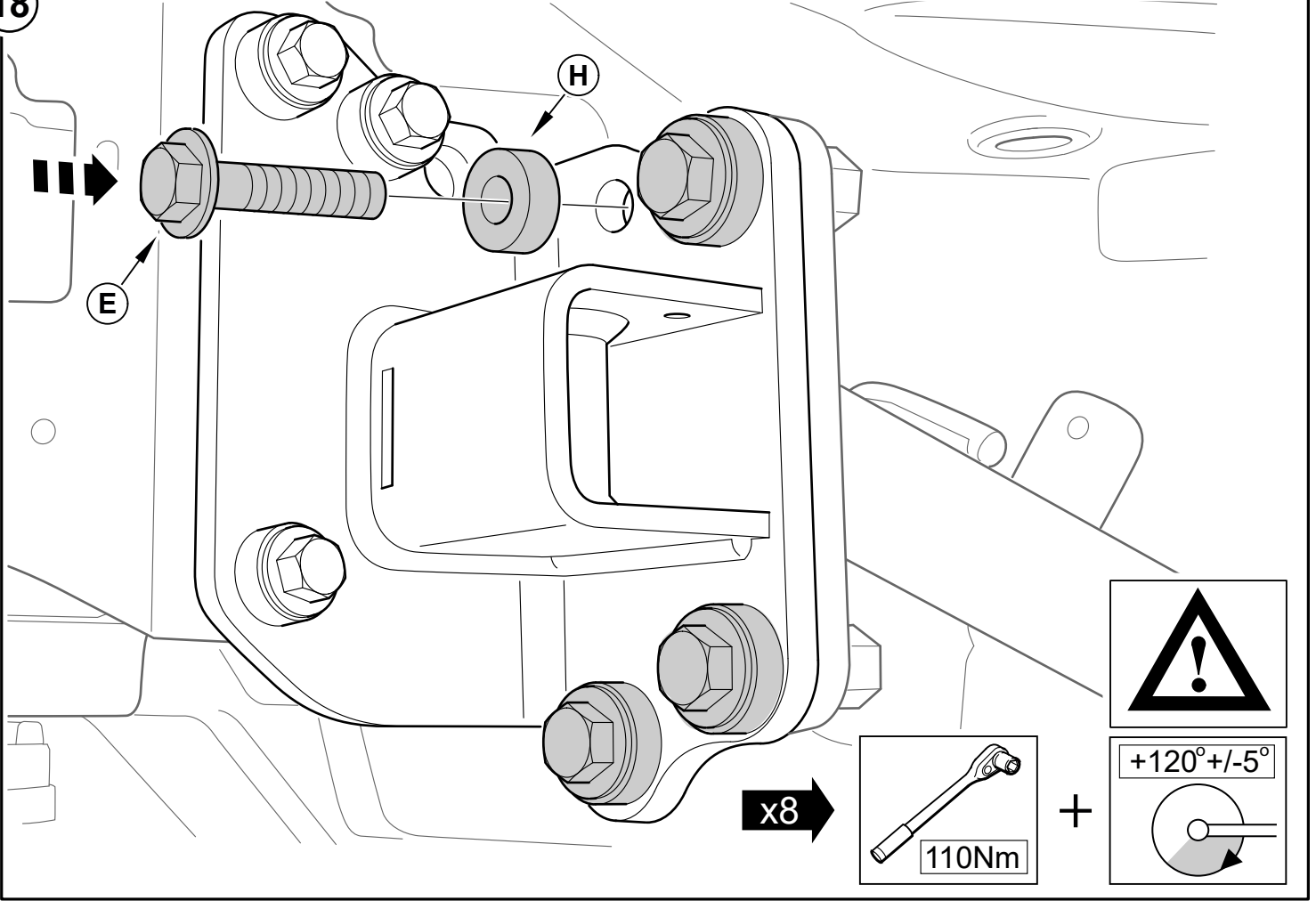

19

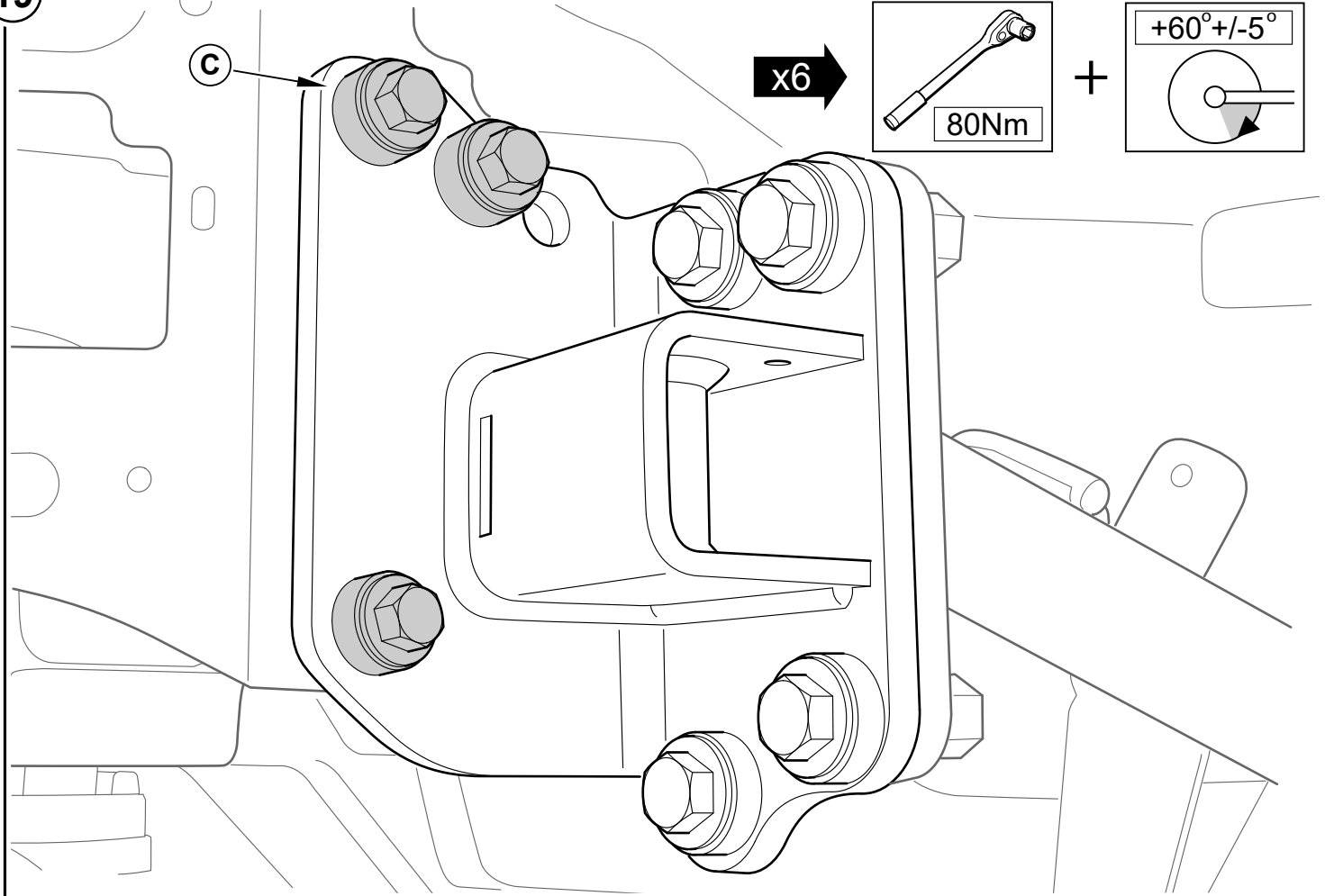

20

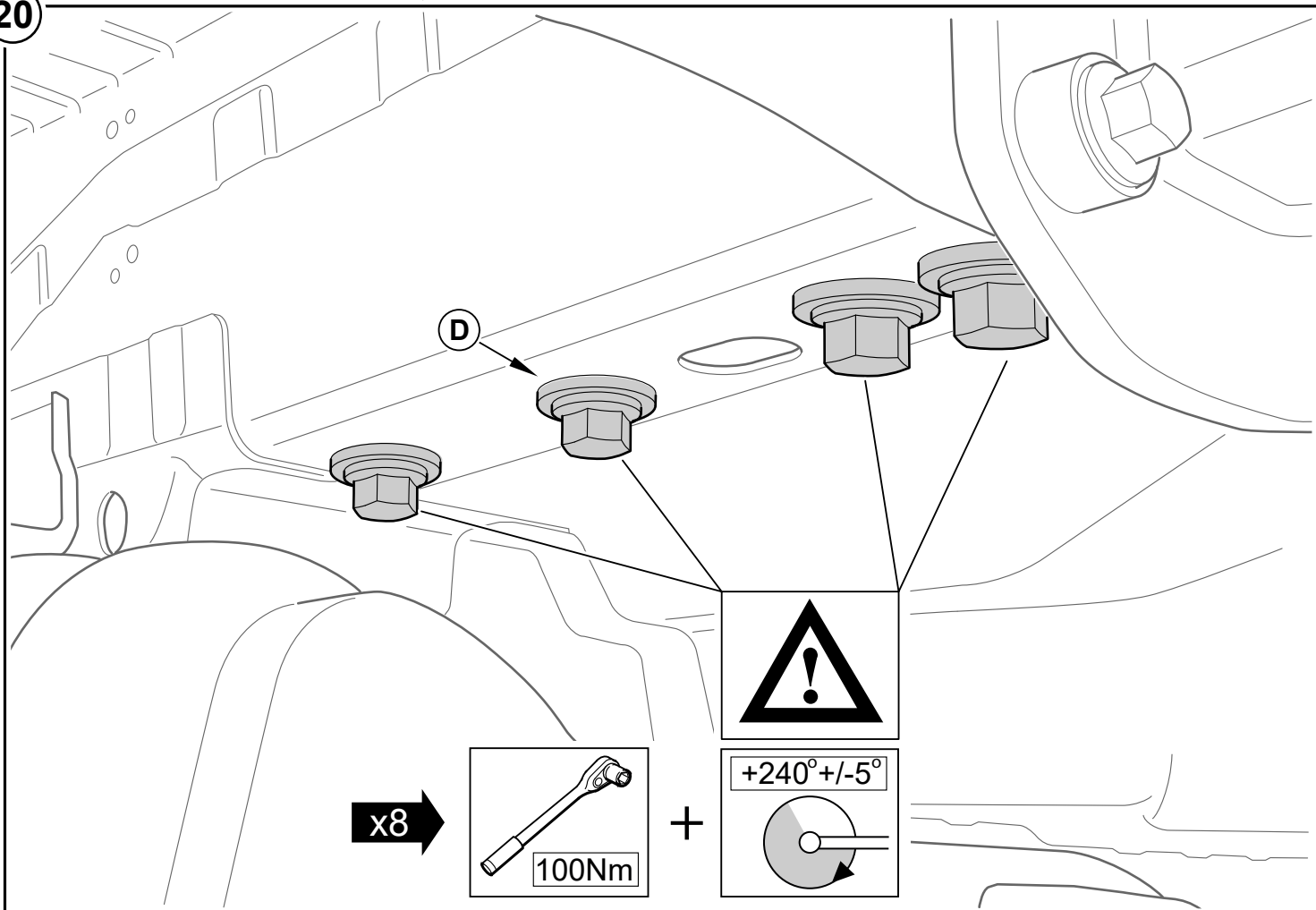



**VPLCT0142**



6/8



**VPLCT0148**



7/8



21

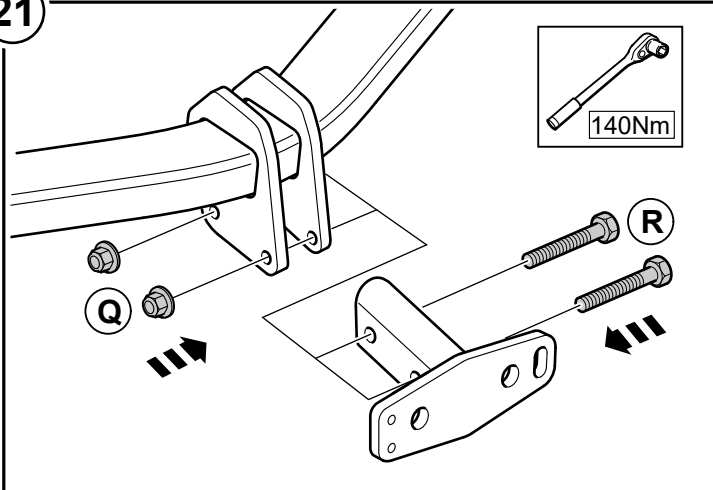

22

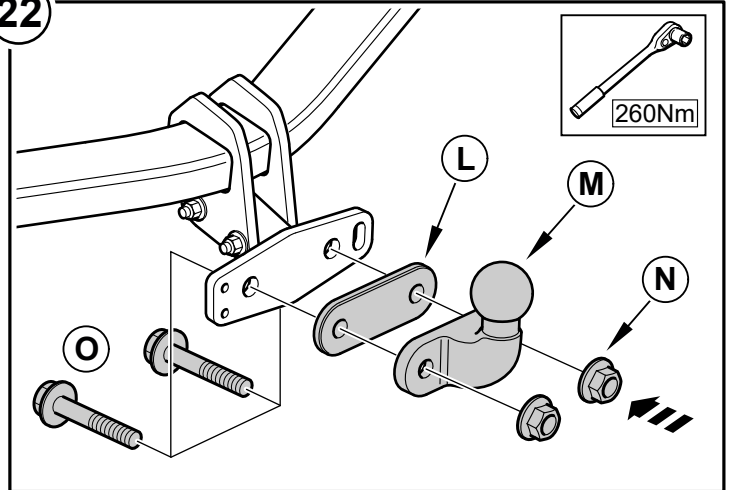

23

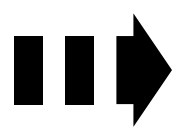
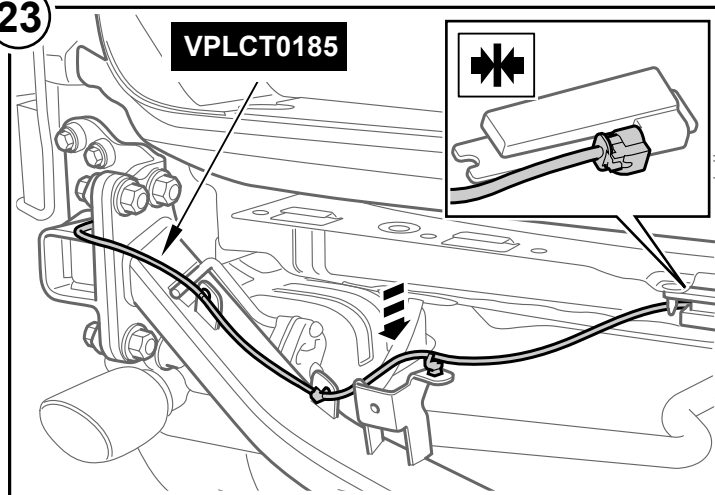

25

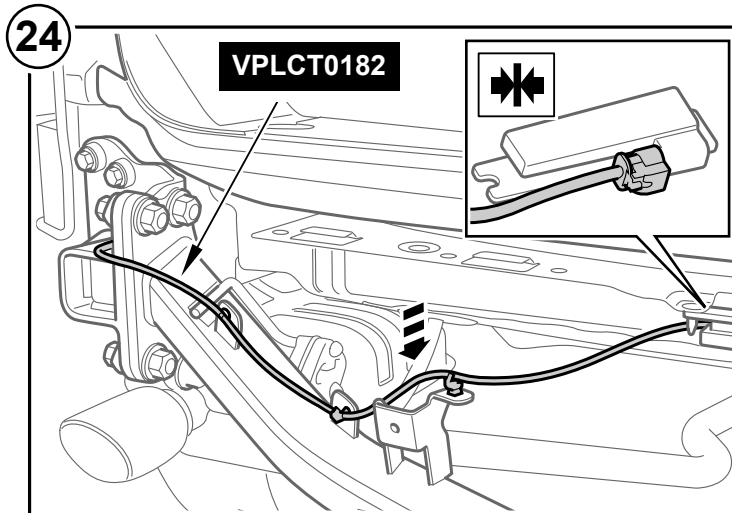
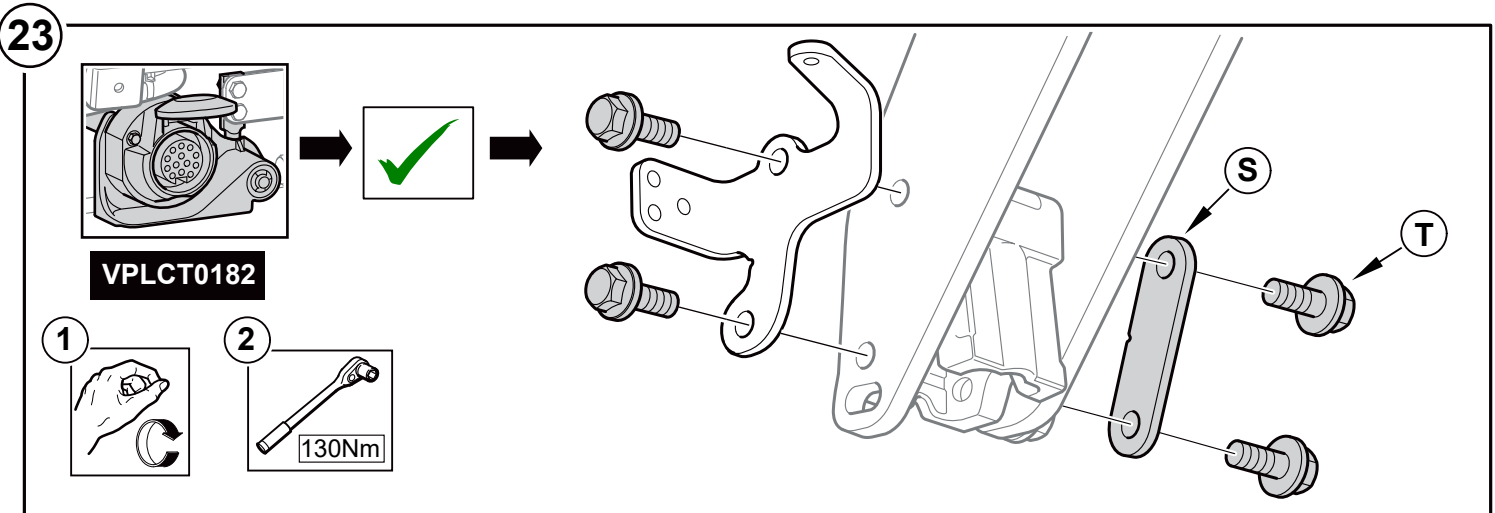
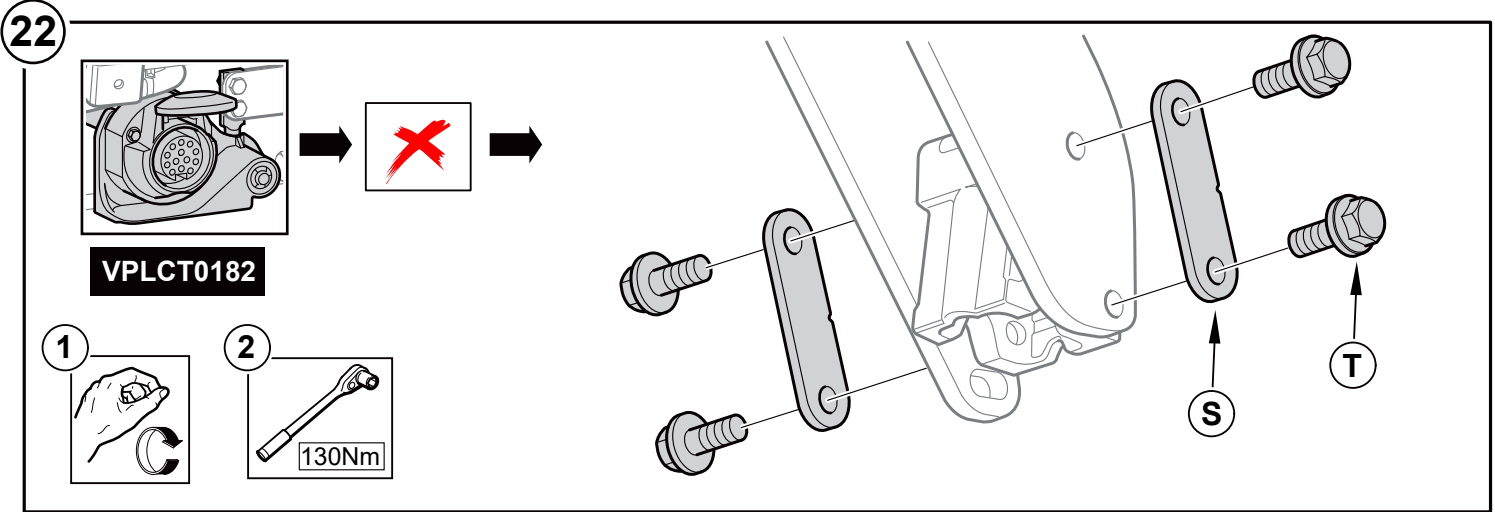
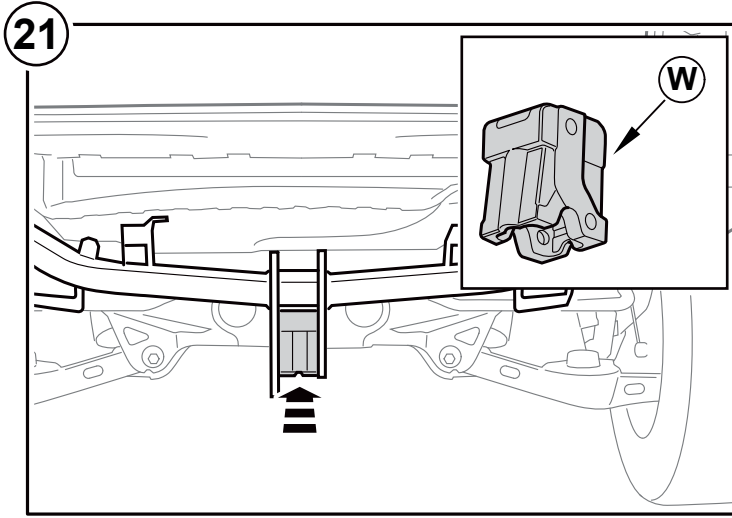

25

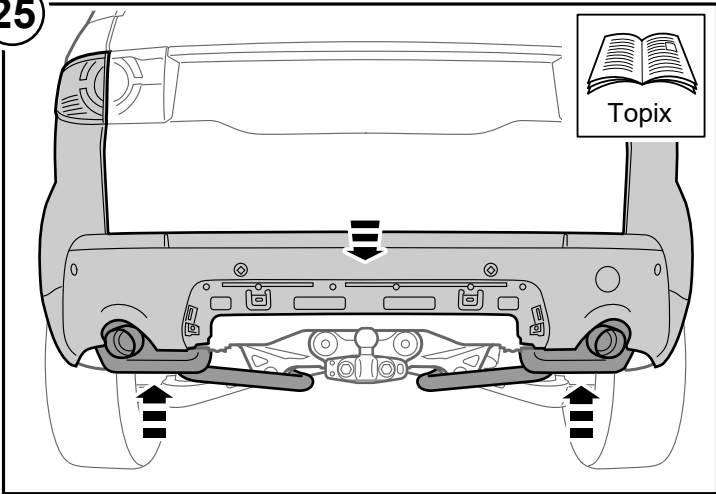

26

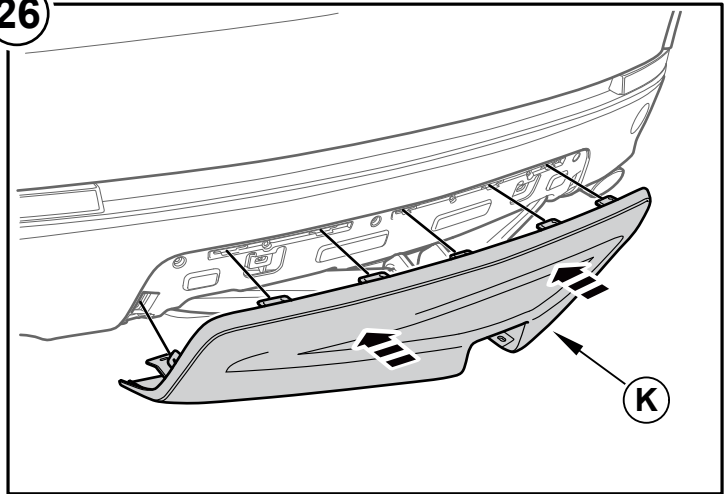

27

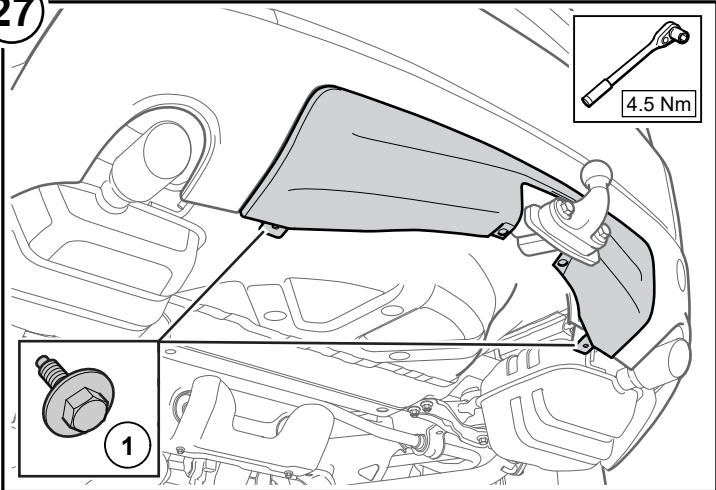

28

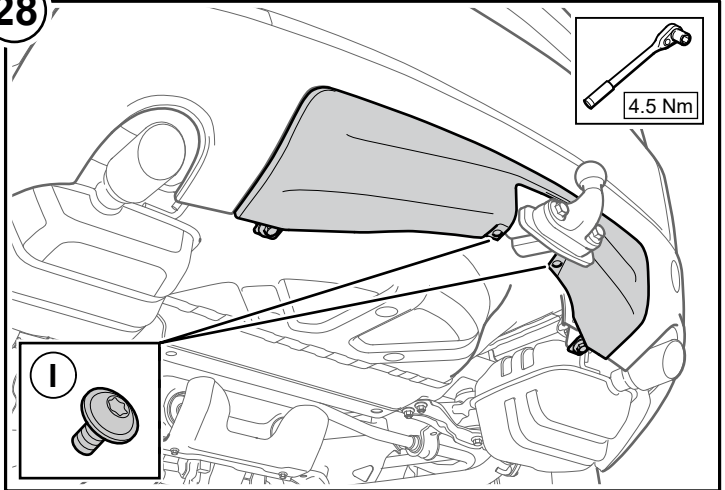

29

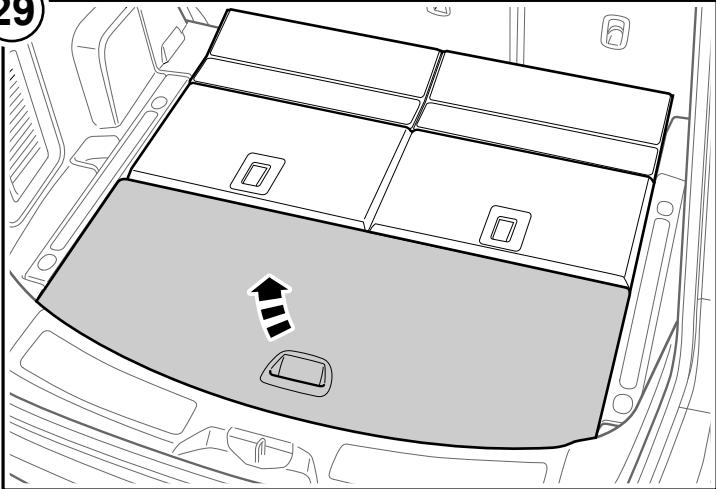

30

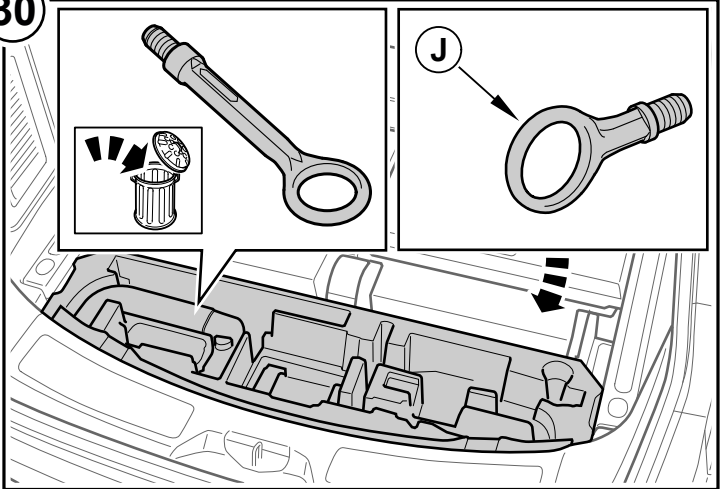

31

