

LAND ROVER

Discovery Sport

Towbar-Bolt On Ball FITTING INSTRUCTION

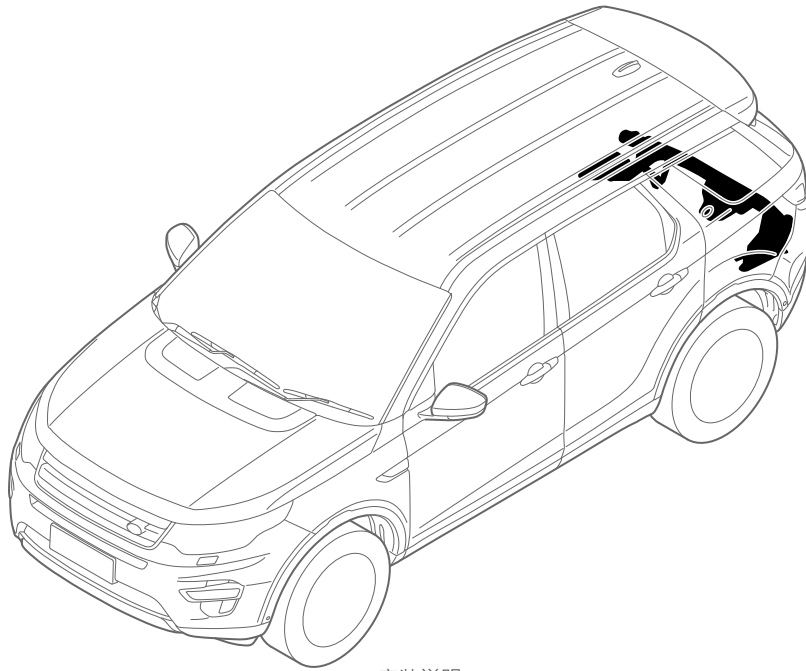

安装说明

拖车杆 — 螺栓连接式球 / 法兰式

EINBAUANLEITUNG

Anhängerkupplung – Anschraubkugel

INSTRUCTION DE MONTAGE

Barre de remorquage – Boulonnage sur boule

ISTRUZIONI PER L'USO

Barra di traino - Fissa a sfera

INSTRUCCION DE MONTAJE

Barra de remolque – Tipo bola atornillada

INSTRUÇÕES DE MONTAGEM

Barra de reboque - Esfera de engatar

Инструкции по установке

Тягово-цепное устройство -
шаровое с болтовым креплением

MONTAGEHANDLEIDING

Trekhaak - schroeftrekhaak

取付用マニュアル

けん引バー - ボルト オン ボール

설치 지침

볼에 장착된 토우바 볼트

Instruções de instalação

Parafuso da barra de reboque, bola

LAF0339_5E

PART No. VPLCT0140 Issue no. 5



WARNING!

Accessories which are not properly fitted can be dangerous. Read the instructions carefully prior to fitting. Whilst fitting, comply with instructions at all times. If in doubt, contact your nearest approved dealer.

警告!

未恰当地安装配件将造成安全隐患。安装前,请仔细阅读说明书。安装时,请始终遵照说明书。如有疑问,请就近联系经认可的经销商。

ACHTUNG!

Von nicht einwandfrei verstauten Gegenständen können Gefahren ausgehen. Vor dem Einbau die Anleitung sorgfältig lesen. Während des Einbaus immer die Anleitung beachten. Im Zweifelsfall einen Vertragspartner zu Rate ziehen.

AVERTISSEMENT!

Les accessoires montés de manière incorrecte peuvent présenter un danger. Lire attentivement les instructions avant de procéder au montage. Se référer systématiquement aux instructions pendant le montage. En cas de doute, contacter le concessionnaire agréé le plus proche.

AVVERTENZA!

Gli accessori non montati correttamente possono essere pericolosi. Leggere attentamente le istruzioni prima del montaggio. Durante il montaggio, attenersi scrupolosamente alle istruzioni. In caso di dubbi, contattare il concessionario più vicino.

ADVERTÉNCIA!

Los accesorios que no encajen correctamente pueden ser peligrosos. Lea detenidamente las instrucciones antes de proceder al montaje. Durante el montaje, siga las instrucciones en todo momento. Si tiene alguna duda, póngase en contacto con el concesionario oficial más cercano.

AVISO!

Os acessórios montados inadequadamente podem ser perigosos. Leia cuidadosamente as instruções antes da montagem. Durante a montagem, siga sempre as instruções. Em caso de dúvida, contacte o concessionário autorizado mais próximo.

ВНИМАНИЕ!

Неправильно установленные аксессуары могут быть опасны. Перед установкой внимательно прочитайте инструкцию. При установке не нарушайте требования инструкции. В случае возникновения вопросов обратитесь к авторизованному дилеру.

WAARSCHUWING!

Onjuiste gemonteerde accessoires kunnen risico's opleveren. Lees de instructies zorgvuldig door voordat u overgaat tot monteren. Houd u bij het monteren altijd aan de instructies. Neem bij twijfel contact op met de dichtstbijzijnde erkende dealer.

警告!

正しく取り付けられていないアクセサリは危険である。取り付けの前に、手順を注意深く読むこと。取り付け作業中は、いつでも手順書を順守すること。疑問等がある場合、近くの正規ディーラーに問い合わせること。

경고!

올바르게 장착되지 않은 액세서리는 위험을 유발할 수 있습니다. 장착하기 전에 지침을 주의 깊게 읽으십시오. 장착하는 동안에는 항상 지침을 준수하십시오. 궁금한 사항이 있으면 가까운 승인 딜러점에 문의하십시오.

AVISO!

Acessórios incorretamente instalados podem ser perigosos. Leia cuidadosamente as instruções antes de instalar. Durante a instalação, obedeça a todas as instruções. Caso tenha dúvidas, entre em contato com o revendedor autorizado mais próximo

Fitting Instructions can be found at the URL below:

有关安装说明, 请参见下方的 URL:

Für eine Einbauanleitung siehe untenstehende URL:

Les instructions de montage sont disponibles à l'adresse URL ci-dessous :

Le istruzioni di montaggio sono disponibili all'indirizzo URL seguente:

Las instrucciones de montaje se pueden encontrar en la siguiente URL:

As Instruções de Montagem encontram-se no seguinte URL:

Инструкции по установке приведены на веб-сайте по следующему адресу:

De montage-instructies vindt u op de onderstaande website:

該当手順については、以下の URL を参照:

장착 지침은 아래 URL에서 확인할 수 있습니다.

As instruções de instalação podem ser encontradas na URL a seguir:

www.ownerinfo.jaguar.com

www.ownerinfo.landrover.com

MOTOR VEHICLE DATA

GB

Bolt-on Ball

Type: BRINK 5532
 D-value: 12,65kN
 Vertical coupling load: 175kg
 Coupling class: A50-X
 Manufacturer: Brink Towing Systems B.V.

Model application: Land Rover Discovery Sport
 EC-Type Approval No: E11 55R-0110046
 Max. Trailer Weight: 2500kg
 JLR Part no: FK7M-F19D520-B

FAHRZEUGDATEN

D

Schraub-Kugelkopf

Typ: BRINK 5532
 D-Wert: 12,65 kN
 Vertikale Kupplungsbelastung: 175 kg
 Kupplungsklasse: A50-X
 Hersteller: Brink Towing Systems B.V.

Modellanwendung: Land Rover Discovery Sport
 EC-Zulassungsnummer: E11 55R-0110046
 Max. Anhängergewicht: 2500 kg
 JLR Teile-Nr.: FK7M-F19D520-B

DONNEES - VEHICULE AUTOMOBILE

F

Crochet à boulonner

Type: BRINK 5532
 Valeur D: 12,65 kN
 Charge d'accouplement vertical: 175 kg
 Classe d'accouplement: A50-X
 Fabricant: Brink Towing Systems B.V.

Modèle concerné: Land Rover Discovery Sport
 N° d'homologation type CE: E11 55R-0110046
 Max. Poids de la remorque: 2500 kg
 Référence JLR: FK7M-F19D520-B

DATI PER L' AUTOVEICOLO

I

Sfera imbullonata

Tipo: BRINK 5532
 Valore D: 12,65 kN
 Carico accoppiamento verticale: 175 kg
 Classe di accoppiamento: A50-X
 Costruttore: Brink Towing Systems B.V.

Applicazione modello: Land Rover Discovery Sport
 N. di approvazione tipo CE: E11 55R-0110046
 Max. Peso rimorchio: 2500 kg
 N. parte JLR: FK7M-F19D520-B

DATOS DEL COCHE

E

Bola atornillada

Tipo: BRINK 5532
 Valor D: 12,65 kN
 Carga vertical de acoplamiento: 175 kg
 Clase de acoplamiento: A50-X
 Fabricante: Brink Towing Systems B.V.

Modelo de aplicación: Land Rover Discovery Sport
 Número de homologación CE: E11 55R-0110046
 Máx. Peso del remolque: 2500 kg
 Número de pieza de JLR: FK7M-F19D520-B

DADOS DE VEÍCULOS A MOTOR

P

Esfera de aparafusar

Tipo: BRINK 5532
 Valor D: 12,65 kN
 Carga no acoplamiento vertical: 175kg
 Classe do acoplamiento: A50-X
 Fabricante: Brink Towing Systems B.V.

Aplicação de modelo: Land Rover Discovery Sport
 Aprovação de tipo EC n.º E11 55R-0110046
 Máx. Peso do atrelado: 2500 kg
 N.º de peça JLR: FK7M-F19D520-B

VOERTUIGSPECIFICATIES

NL

Aanboutbare kogel

Tipo: BRINK 5532
 Valor D: 12,65 kN
 Carga vertical de acoplamiento: 175 kg
 Clase de acoplamiento: A50-X
 Fabricante: Brink Towing Systems B.V.

Modelo de aplicación: Land Rover Discovery Sport
 Número de homologación CE: E11 55R-0110046
 Máx. Peso del remolque: 2500 kg
 Onderdeelnr. JLR: FK7M-F19D520-B

АВТОТРАНСПОРТА ДАННЫЕ

RU

Болт шаровой опоры

Тип: BRINK 5532
 Теоретическое горизонтальное динамическое усилие на сцепке-
 (D-Value): 12,65 кН
 Вертикальная нагрузка на сцепное устройство: 175 кг
 Класс сцепного устройства: A50-X
 Изготовитель: Brink Towing Systems B.V.

Модель автомобиля: Land Rover Discovery Sport
 Регистрационный номер в ЕС: E11 55R-0110046
 Макс. масса прицепа: 2500 кг
 Номер детали по каталогу JLR: FK7M-F19D520-B

自動車データ

日

螺栓紧固式牵引球

类型: BRINK 5532
 D 值: 12.65 千牛
 垂直接轴器负荷: 175 千克
 联轴器类别: A50-X
 制造商: Brink Towing Systems B.V.
 应用车型: Land Rover Discovery Sport
 EC 类型许可编号: E11 55R-0110046
 最大 拖车重量: 2500 千克
 JLR 零件号: FK7M-F19D520-B

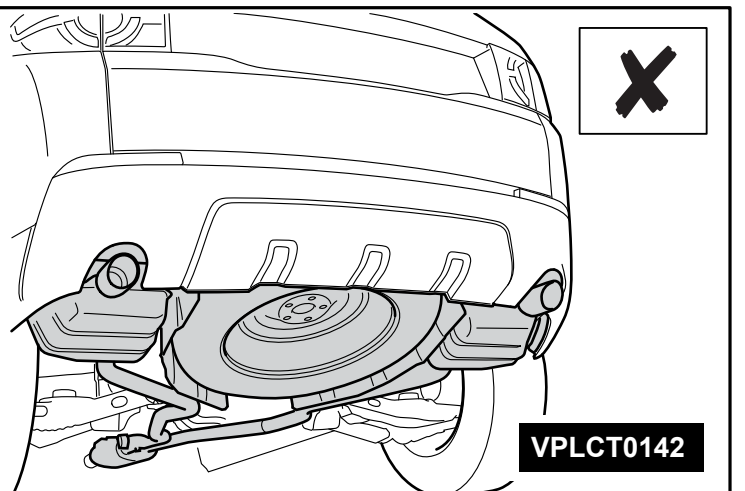
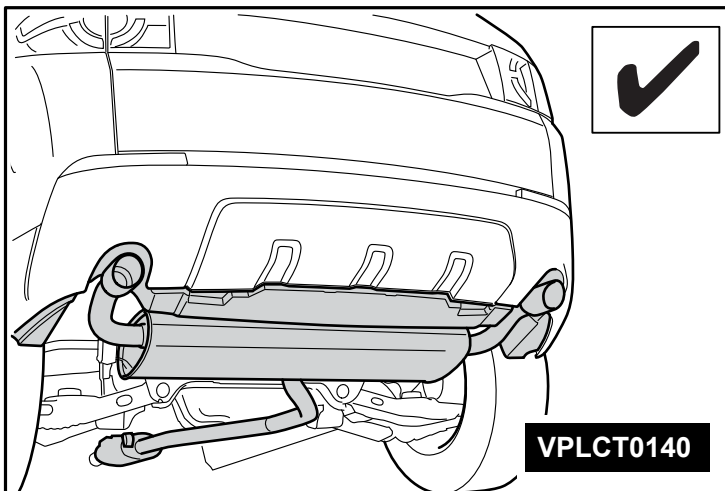
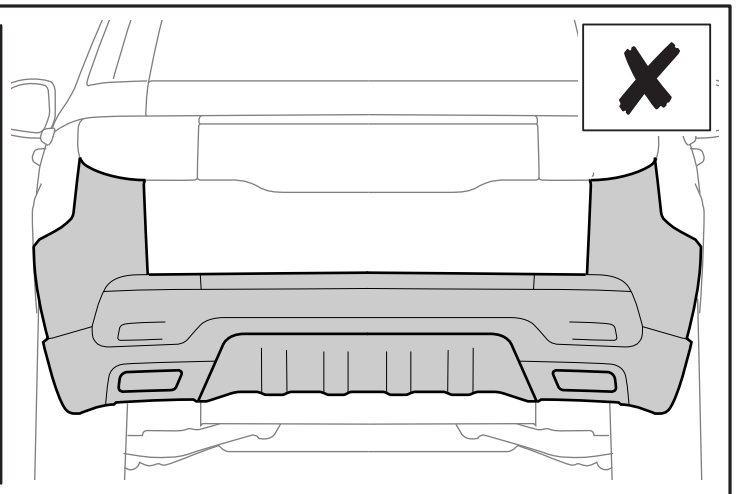
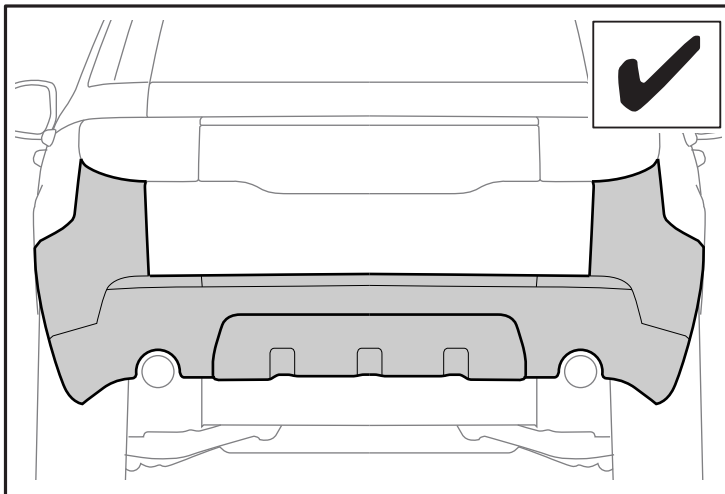
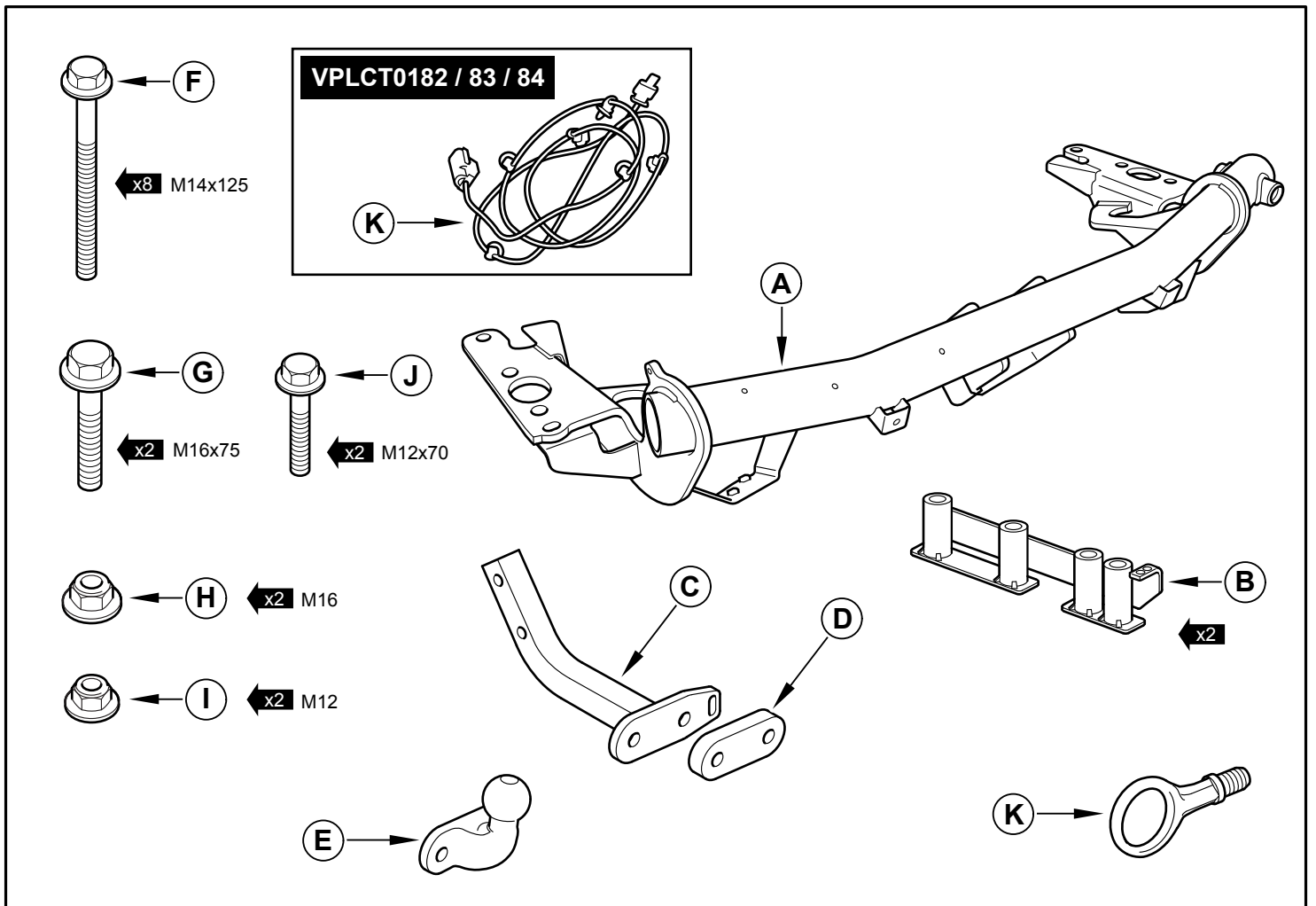

The following instructions are valid for both sides of the vehicle.

以下説明适用于车辆两侧。

Die folgenden Anweisungen gelten für beide Seiten des Fahrzeugs.

Les instructions suivantes sont valables pour les deux côtés du véhicule.

Le seguenti istruzioni sono valide per entrambi i lati del veicolo.

Las siguientes instrucciones son válidas para ambos lados del vehículo.

As instruções seguintes são válidas para ambos os lados do veículo.

Приведенные инструкции действительны для обеих сторон автомобиля.

De volgende instructies gelden voor beide zijden van het voertuig.

車両の両サイドに対して、以下の指示に従う。

1

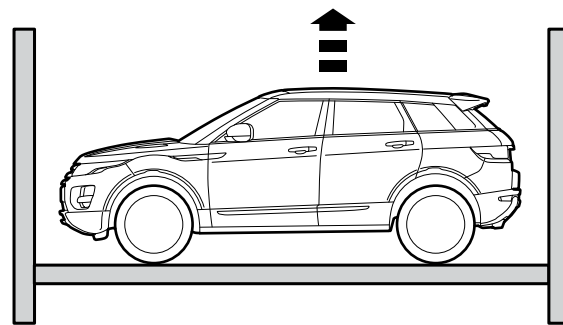

2

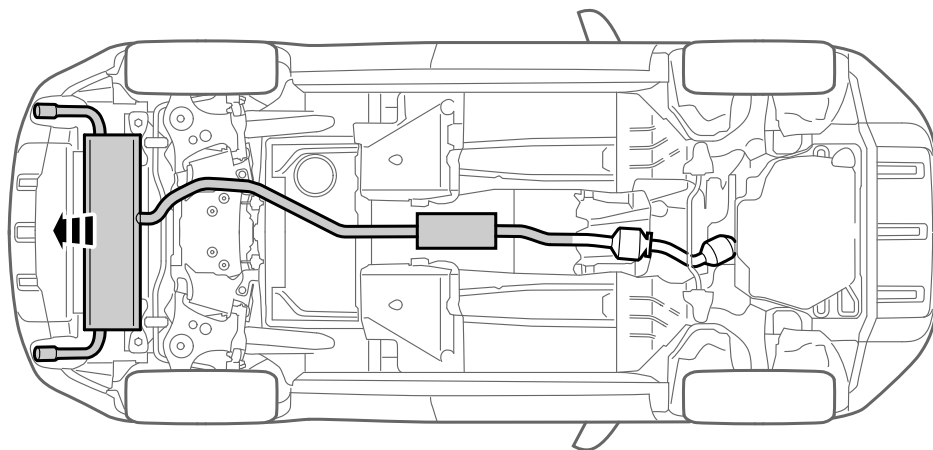

3

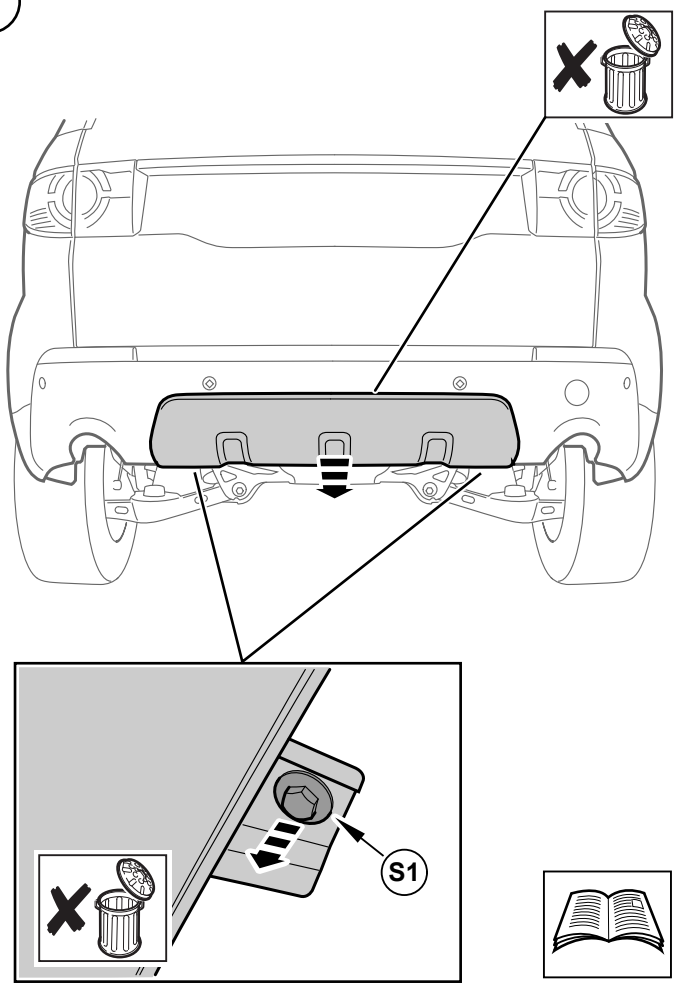

4

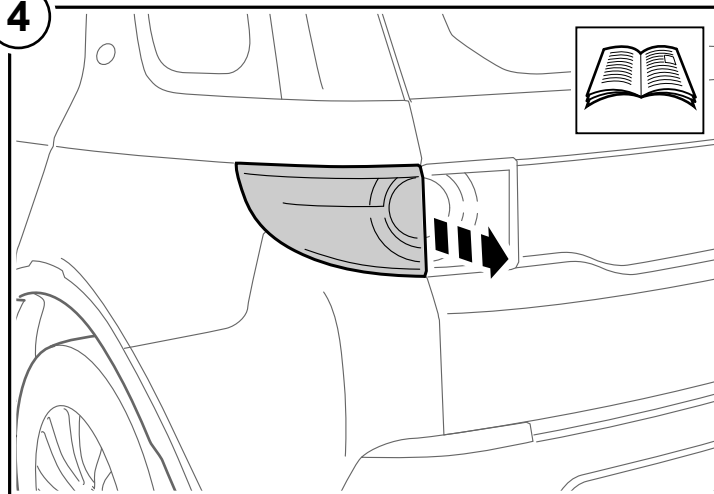

5

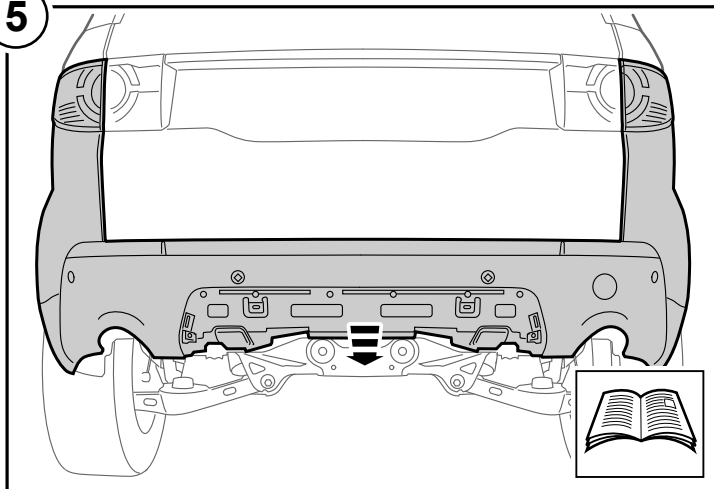

6

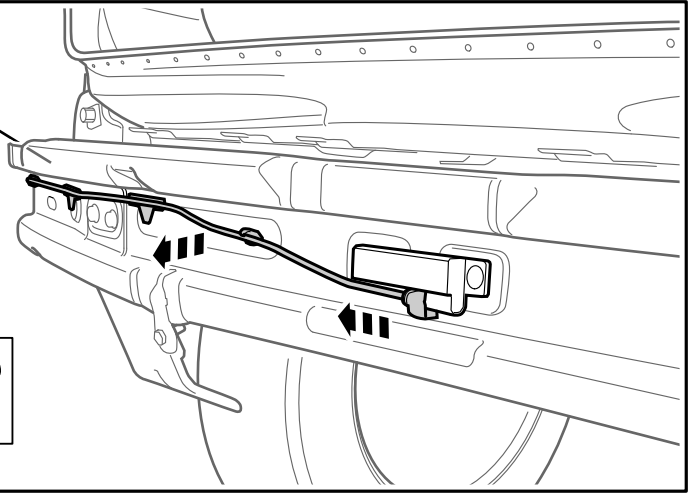
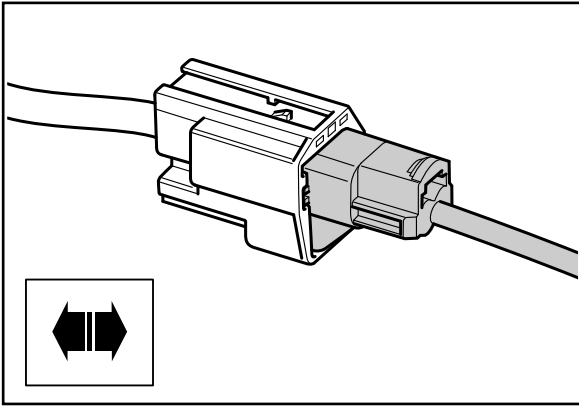

7

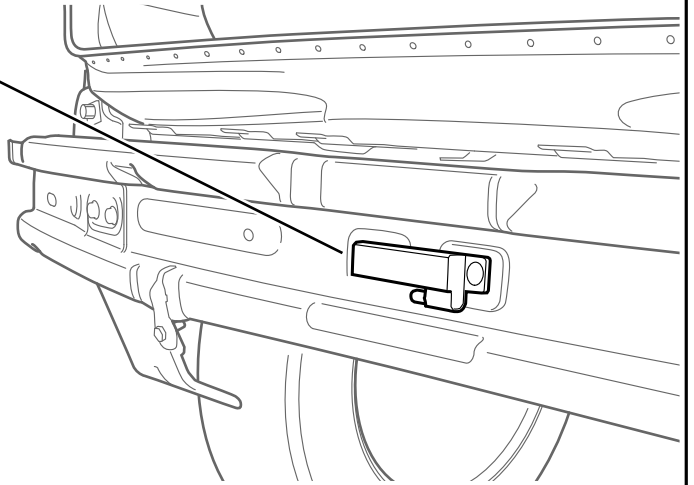
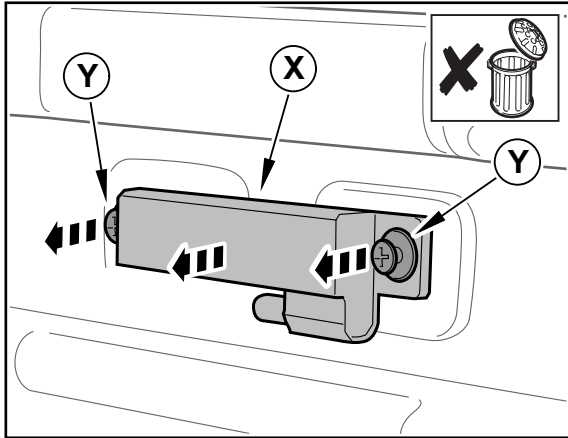

8

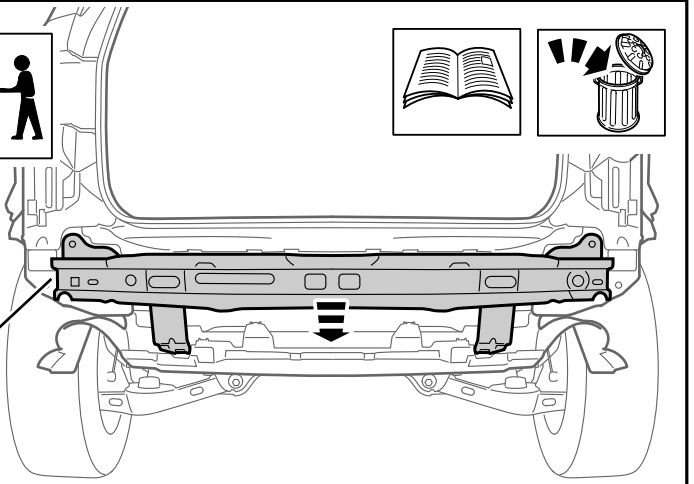
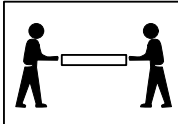
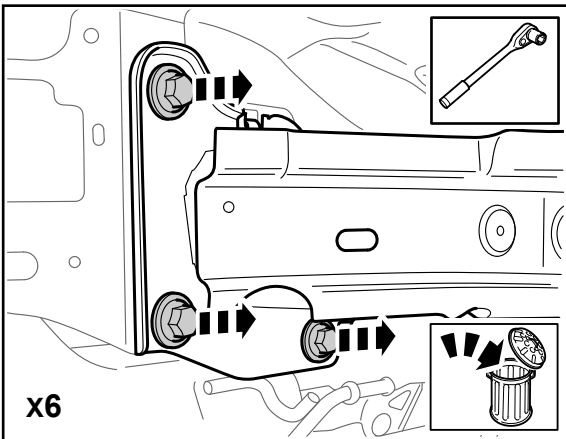

9

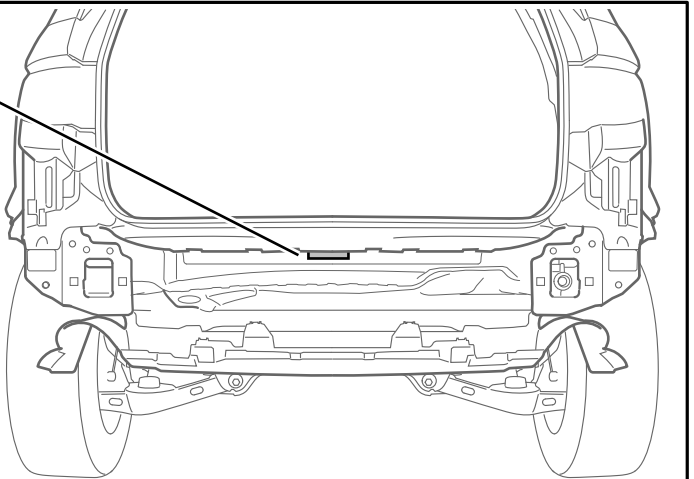
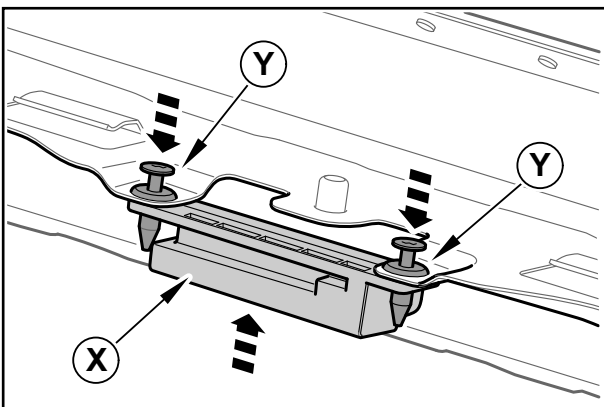

10

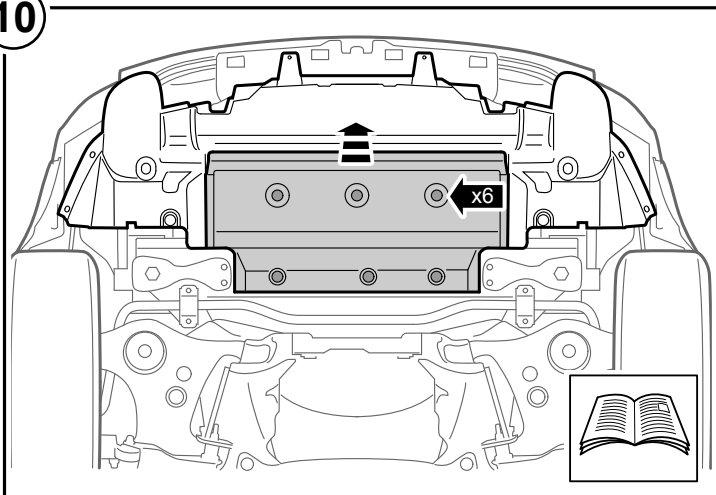

11

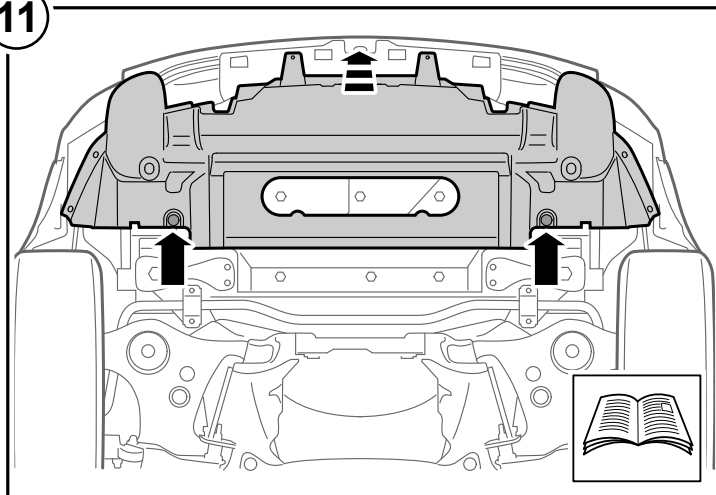

12

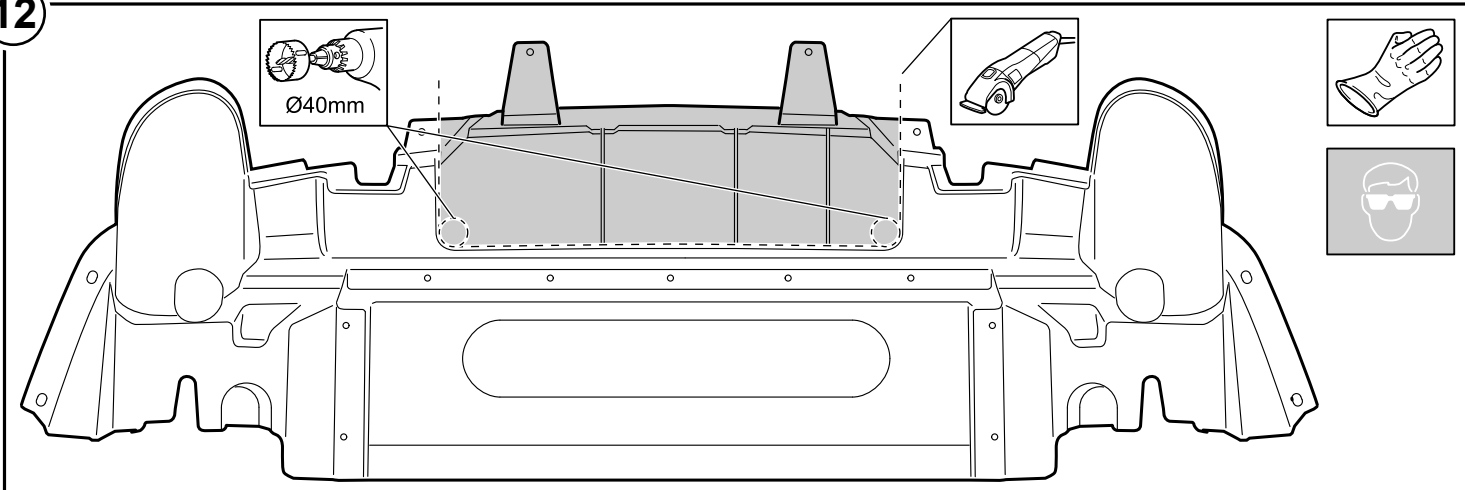

13

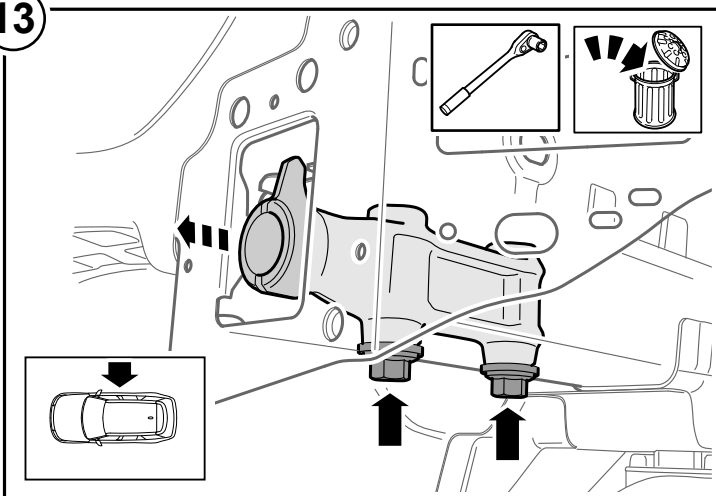

14

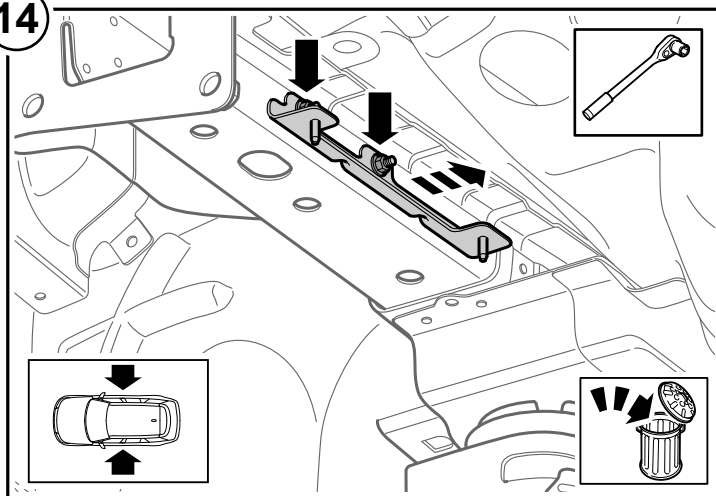

15

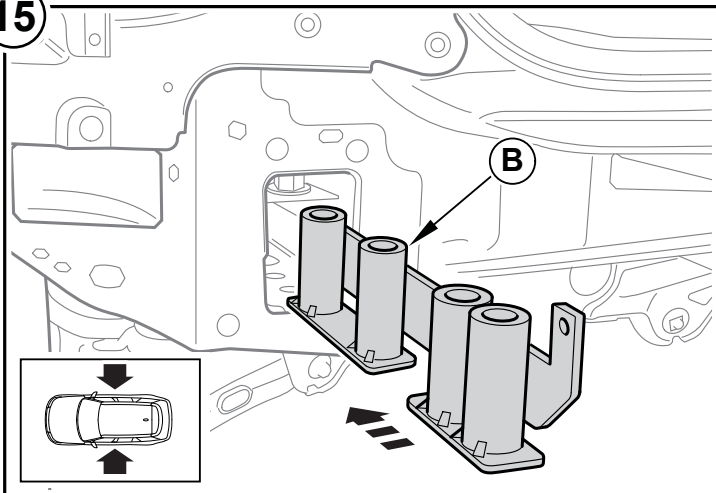

16

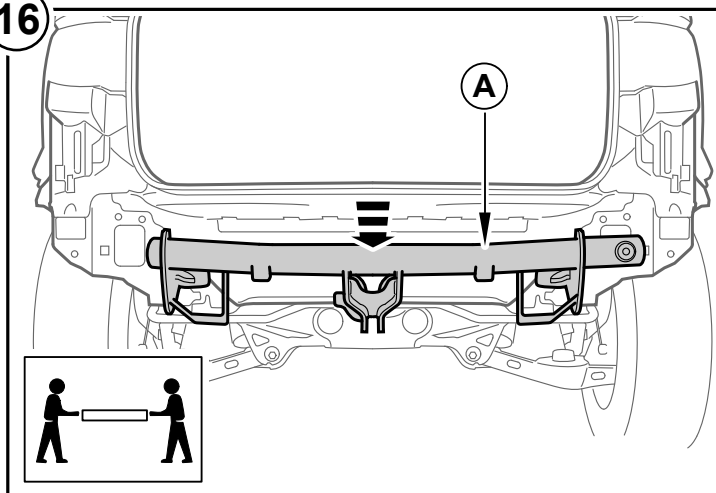

17

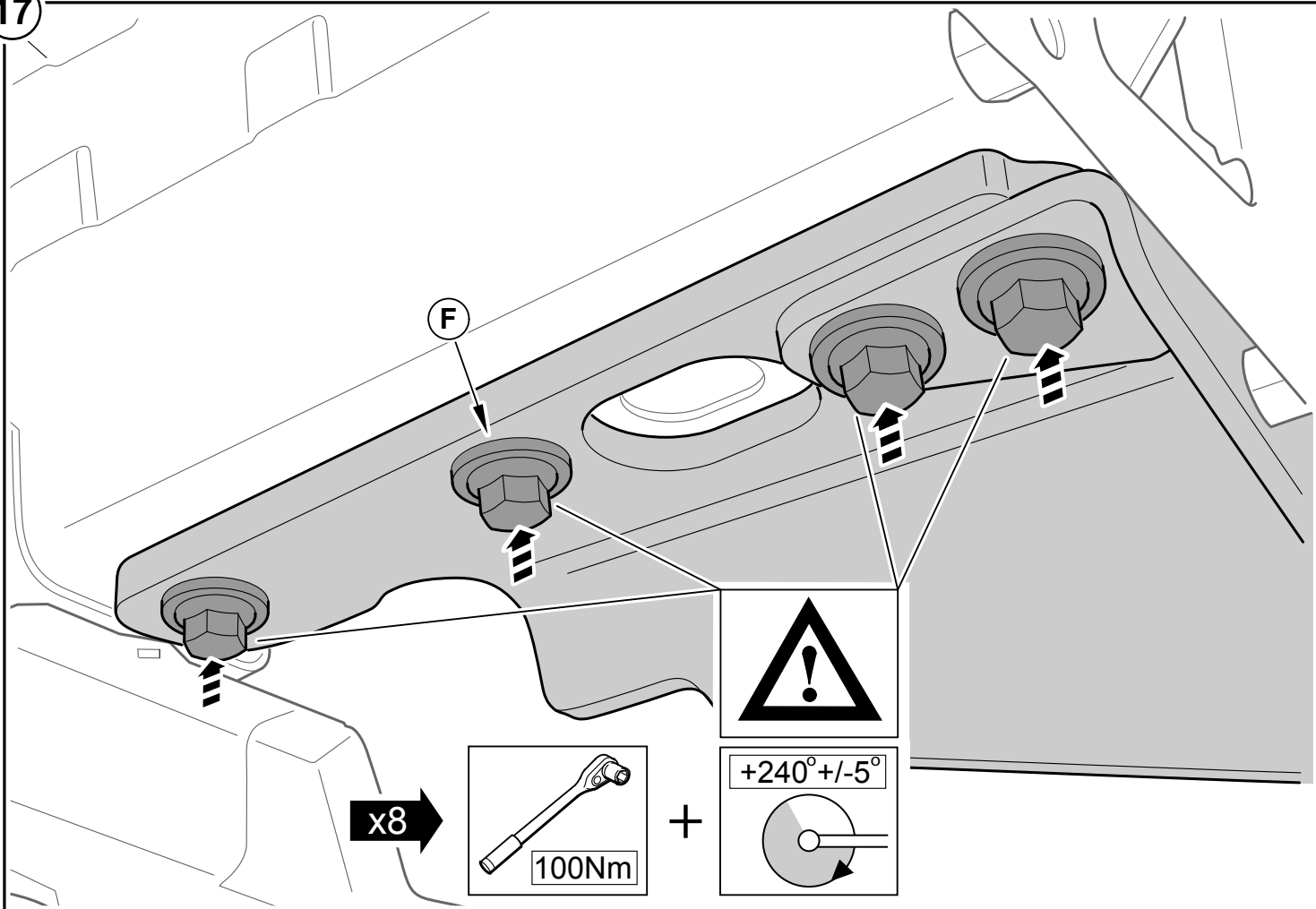

18

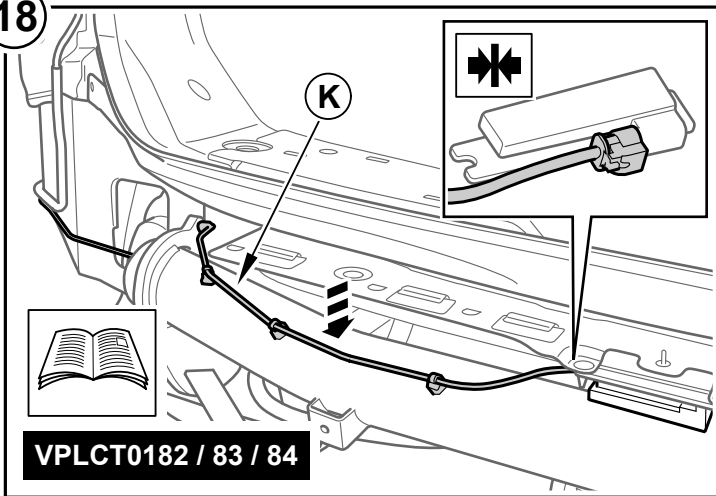

19

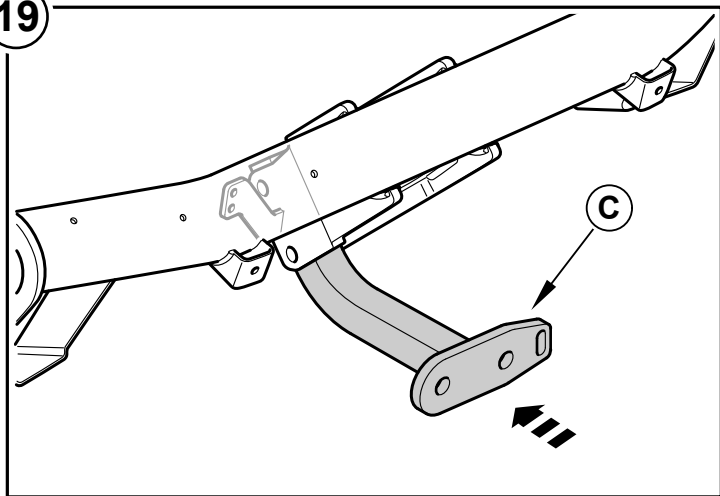

20

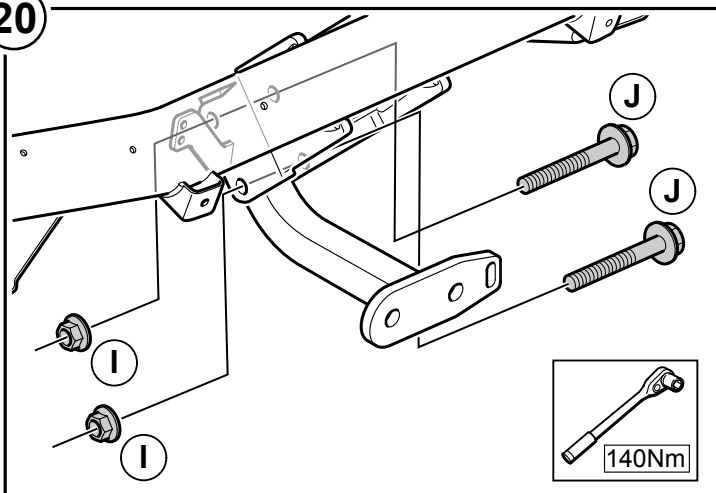

21

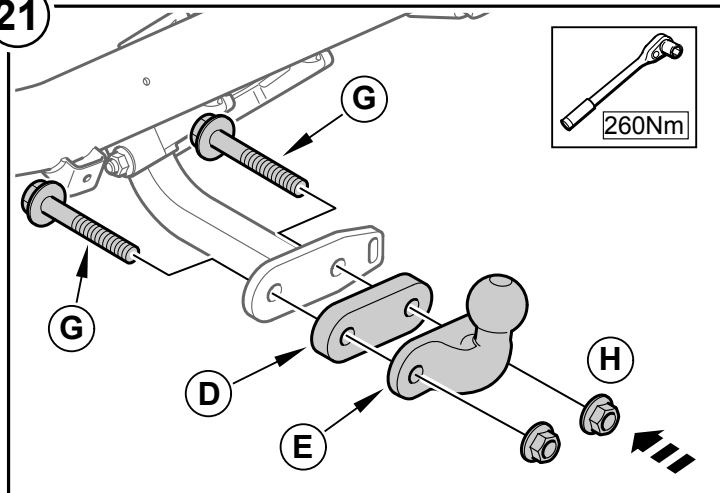

22

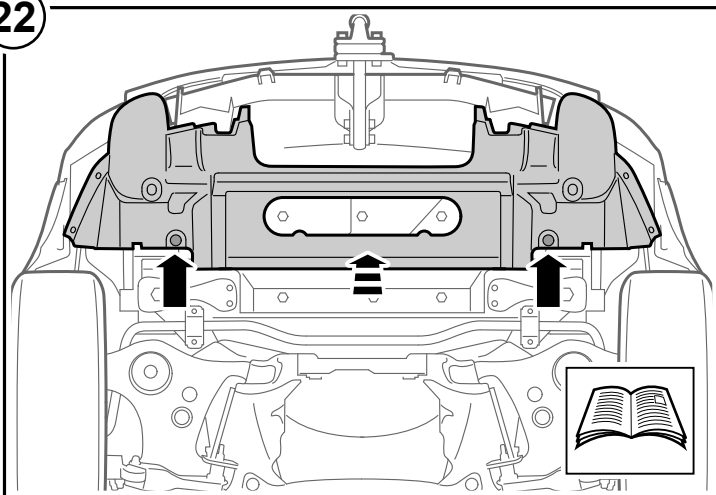

23

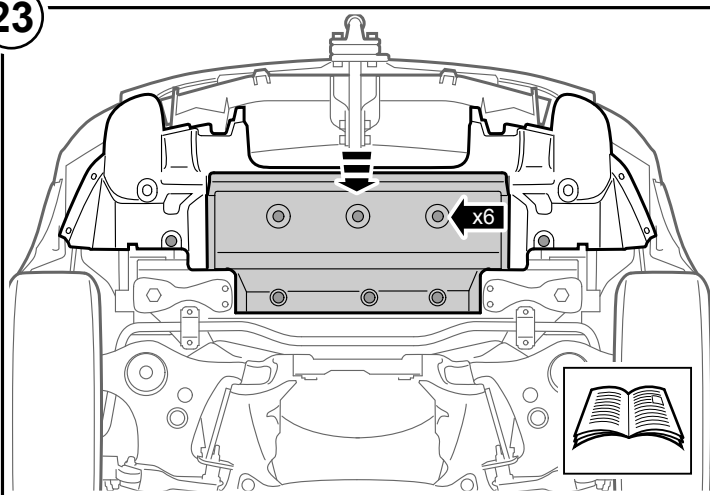

24

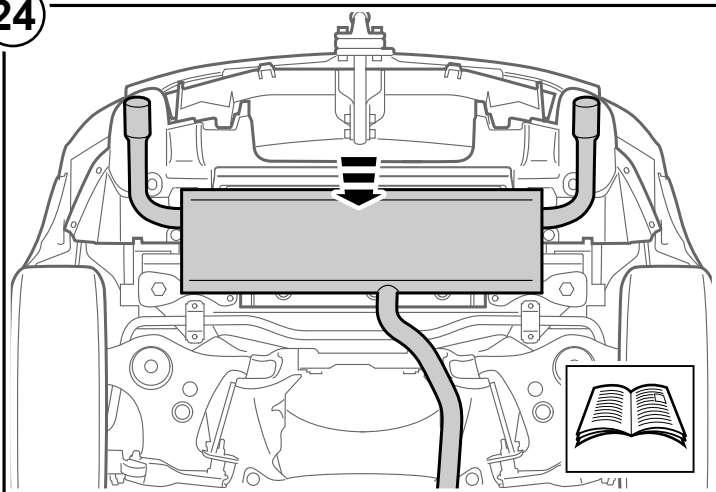

25

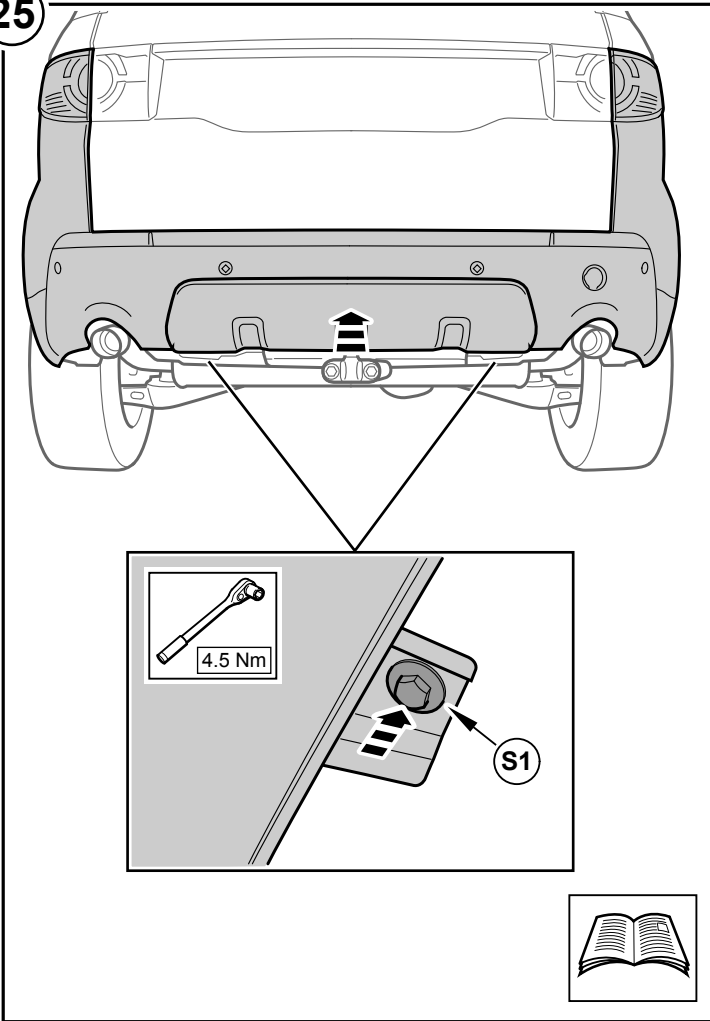

26

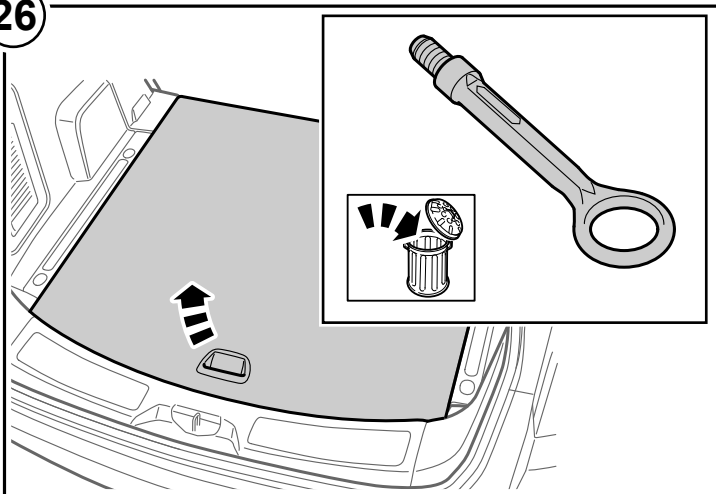

27

