



## ACCESSORIES

### WARNING

Accessories which are not properly fitted can be dangerous. Read the instructions carefully prior to fitting. Whilst fitting, comply with the instructions at all times. If in doubt, contact your nearest Land Rover dealer.

### ACHTUNG!

Nicht sachgemäß montiertes Zubehör kann gefährlich sein. Lesen Sie die Montageanleitung sorgfältig, bevor Sie das Teil montieren. Halten Sie sich bei der Montage an die Anleitung. Bei Unsicherheiten wenden Sie sich bitte an Ihren Land Rover Händler.

### AVERTISSEMENT

Les accessoires qui ne sont pas correctement montés risquent d'être dangereux. Veuillez lire soigneusement les instructions avant d'effectuer la pose. Respectez toujours les instructions en cours de pose. En cas de doute, consultez votre concessionnaire Land Rover local.

### AVVERTENZA

Gli accessori non sistemati come previsto possono essere pericolosi. Leggere attentamente le istruzioni prima del fissaggio. Durante il montaggio seguire sempre le relative istruzioni. In caso di dubbio rivolgersi al più vicino concessionario della Land Rover.

### ADVERTÊNCIA!

Os Acessórios que não são montados adequadamente podem ser perigosos. Leia as instruções cuidadosamente antes de montar. Durante a montagem, obedeça as instruções todo o tempo. Se tiver alguma dúvida, contacte o Concessionário LandRover mais próximo.

### AVISO

Aquellos accesorios que no hayan sido ajustados debidamente pueden resultar peligrosos. Lea las instrucciones detenidamente antes de iniciar el montaje. Durante el montaje siga las instrucciones en todo momento. En caso de duda póngase en contacto con su Concesionario de Land Rover.

### WAARSCHUWING

Accessoires die niet op de juiste wijze zijn gemonteerd kunnen gevaar opleveren. Lees zorgvuldig de instructies alvorens met de montage te beginnen. Houd u tijdens de montage te allen tijde aan de instructies. Neem bij twijfel contact op met de dichtstbijzijnde Land Rover dealer.

### ΠΡΟΕΙΔΟΠΟΙΗΣΗ

Τα προαιρετικά εξαρτήματα που δεν έχουν τοποθετηθεί σωστά μπορεί να είναι επικίνδυνα. Διαβάστε τις οδηγίες πριν προχωρήσετε στην τοποθέτησή τους. Κατά την τοποθέτησή, τηρείτε συνεχώς τις οδηγίες. Αν έχετε οποιαδήποτε αμφιβολία, επικοινωνήστε με τον πλησιέστερο αντιπρόσωπο της.

### 注意

正しく取り付けられていない部品があると、事故の原因になります。取付ける前にこのマニュアルをよくお読みください。取付けの際は必ずこのマニュアルにある指示に従ってください。何か不明な点がありましたら、お近くのランド・ローバー社のディーラーまでお問い合わせください。

### ВНИМАНИЕ!

Неправильно установленные дополнительные принадлежности могут представлять опасность. Перед началом установки внимательно ознакомьтесь с инструкциями. В ходе установки строго соблюдайте инструкции. В случае возникновения каких-либо сомнений обращайтесь к ближайшему дилеру компании Land Rover.



## FITTING INSTRUCTION

Towbar - NAS

## EINBAUANLEITUNG

Anhängerkupplung – NAS

## INSTRUCTION DE MONTAGE

Barre de remorquage – NAS

## ISTRUZIONI PER L'USO

Barra di traino - NAS

## INSTRUCCION DE MONTAJE

Barra de remolque - Mercado NAS

## INSTRUÇÕES DE MONTAGEM

Barra de reboque - NAS

## MONTAGEHANDLEIDING

Trekhaak - NAS

## ΟΔΗΓΙΑ ΤΟΠΟΘΕΤΗΣΗΣ

Κοτσαδόρος - NAS

取付用マニュアル

けん引バー - NAS

## Инструкции по установке

Тягово-сцепное устройство - NAS

安装说明  
拖车杆 — 北美标准

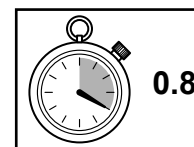



MOTOR VEHICLE DATA		(GB)
Manufacturer - Land Rover Ltd		
Official Motor Type - LF		
Model - FREELANDER from 2006		
TOW BAR INCLUDING BRACKET - DATA		
Coupling class	- A 50-X	
Approval number	- e11 00 5795	
D-Value	- 11 kN	
S-Value	- 150 kg	
Max Trailer Weight	- 2000 kg (NOTE! refer to handbook for gross trainweight.)	

DONNEES - VEHICULE AUTOMOBILE		(F)
Constructeur - Land Rover Ltd		
Type de moteur officiel - LF		
Modèle - FREELANDER à partir de 2006		
DONNEES - BARRE DE REMORQUAGE, SUPPORT INCLUS		
Classe d'accouplement	- A 50-X	
Numéro d'homologation	- e11 00 5795	
Valeur-D	- 11kN	
Valeur-S	- 150 kg	
Poids de remorque maximum	- 2000 kg (NOTA: Se reporter au manuel pour le poids de train brut)	

DATOS DEL COCHE		(E)
Fabricante - Land Rover Ltd		
Tipo oficial de coche - LF		
Modelo - FREELANDER desde 2006		
BARRA DE REMOLQUE INCLUIDO EL SOPORTE - DATOS		
Clase de acoplamiento	- A 50-X	
Número de aprobación	- e11 00 5795	
Valor-D	- 11kN	
Valor-S	- 150 kg	
Peso máximo del remolque	- 2000 kg (NOTA: Consultar el manual para el peso bruto del tren).	

VOERTUIGSPECIFICATIES		(NL)
Fabrikant - Land Rover Ltd		
Officieel motortype - LF		
Model - FREELANDER vanaf 2006		
TREKHAAK INCLUSIEF STEUN - SPECIFICATIES		
Koppelingsklasse	- A 50-X	
Homologatienummer	- e11 00 5795	
D-waarde	- 11 kN	
S-waarde	- 150 kg	
Max. toelaatbaar aanhangwagengewicht	- 2000 kg (N.B. Raadpleeg het instructieboekje voor maximaal toelaatbaar treingewicht.)	

自動車データ		(日)
製造業者 - Land Rover Ltd		
公式モータータイプ - LF		
モデル - 2006 年以降の - FREELANDER		
ブラケット付き牽引バー		
カップリングクラス	- A 50-X	
承認番号	- e11 00 5795	
D 値	- 11 kN	
S 値	- 150kg	
最大トレーラ重量:	- 2000kg (注意! 総トレーン重量については、ノートブック参照)	

FAHRZEUGDATEN		(D)
Hersteller - Land Rover Ltd		
Offizieller Motortyp - LF		
Modell - FREELANDER ab 2006		
ANHÄNGERKUPPLUNG MIT HALTERUNG - DATEN		
Kupplungsklasse	- A 50-X	
Zulassungsnummer	- e11 00 5795	
D-Wert	- 11 kN	
S-Wert	- 150 kg	
Maximales Anhängergewicht	- 2000 kg (Beachte: Höchstzulässiges Gesamtgewicht im Handbuch beachten!)	

DATI PER L' AUTOVEICOLO		(I)
Fabricante - Land Rover Ltd		
Tipo ufficiale di motore - LF		
Modello - FREELANDER dal 2006		
BARRA DI TRAINO COMPRESA SQUADRETTA - DATI		
Classe di accoppiamento	- A 50-X	
Numero di approvazione	- e11 00 5795	
Valore D	- 11 kN	
Valore S	- 150 kg	
Peso massimo del rimorchio	- 2000 kg (NOTA! Per il peso lordo del rimorchio bruto consultare il manuale.)	

DADOS DE VEÍCULOS A MOTOR		(P)
Fabricante - Land Rover Ltd		
Tipo de Motor Oficial - LF		
Modelo - FREELANDER de 2006		
BARRA DE REBOQUE INCLUINDO SUPORTE - DADOS		
Classe de acoplamiento	- A 50-X	
Número de aprovação	- e11 00 5795	
Valor D	- 11 kN	
Valor S	- 150 kg	
Peso máximo de reboque	- 2000 kg (NOTA! consulte o manual para o peso bruto de trem).	

ΣΤΟΙΧΕΙΑ ΟΧΗΜΑΤΟΣ		(GR)
Κατασκευαστής - Land Rover Ltd		
Επίσημος Τύπος Κινητήρα - LF		
Μοντέλο - FREELANDER μετά το 2006		
ΡΑΒΔΟΣ ΡΥΜΟΥΛΚΗΣΗΣ ΜΕ ΑΓΚΙΣΤΡΟ - ΣΤΟΙΧΕΙΑ		
Κατηγορία ζεύξης	- A 50-X	
Αριθμός έγκρισης	- e11 00 5795	
Τιμή D	- 11 kN	
Τιμή S	- 150 κιλά	
Μέγιστο Βάρος Ρυμούλκας	- 2000 κιλά (ΣΗΜΕΙΩΣΗ! Για το συνολικό μικτό βάρος, ανατρέξτε στο εγχειρίδιο)	

ДАНИЕ О ТРАНСПОРТНОМ СРЕДСТВЕ		(RUS)
Производитель - Land Rover Ltd		
Официальный тип двигателя - LF		
модель - FREELANDER		
СЦЕПНОЕ УСТРОЙСТВО - ДАННЫЕ		
Класс соединений	- A 50-X	
Номер сертификата	- e11 00 5795	
(D - Value)	- 11 kN	
(S - Value)	- 150kg	
Максимальная масса прицепа	- 2000 кг (ПРИМЕЧАНИЕ! см руководство по определению полной массы автопоезда.)	

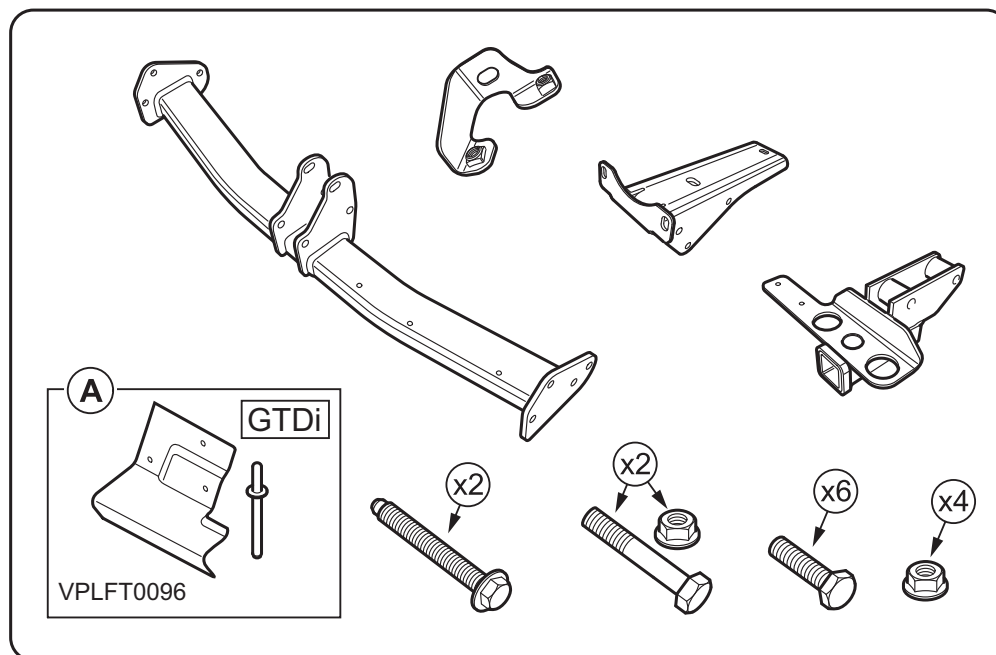
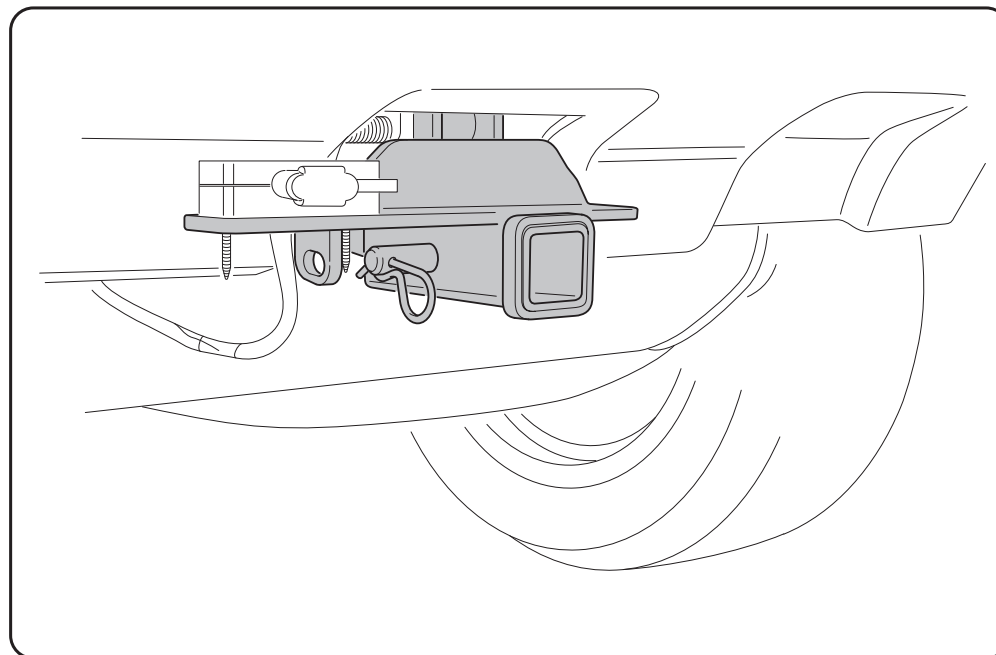

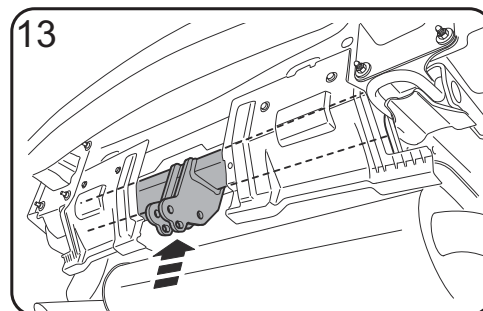
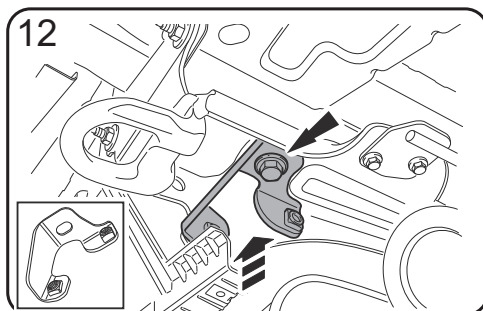
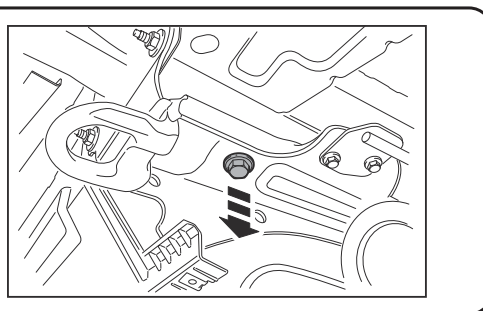
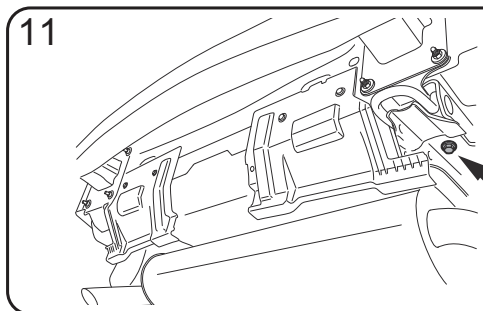
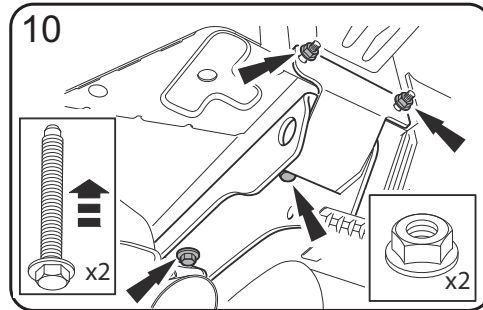
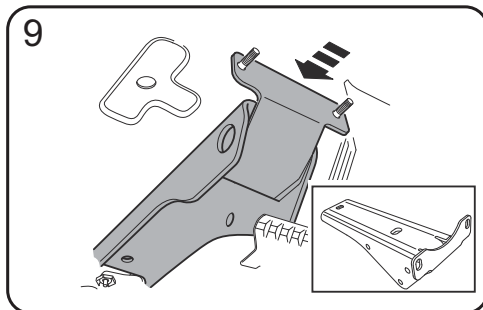
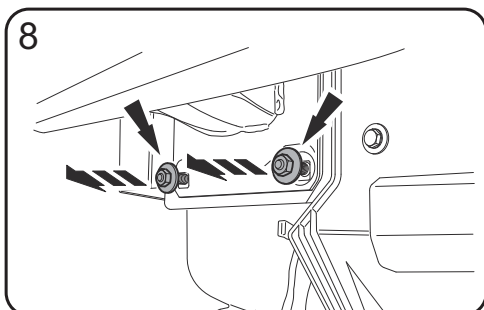
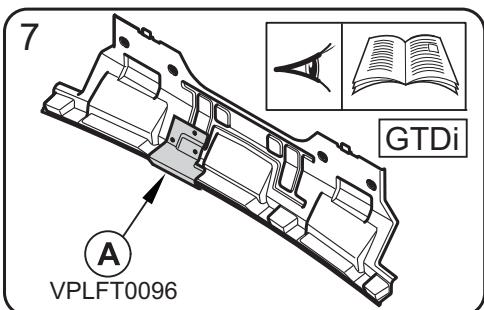
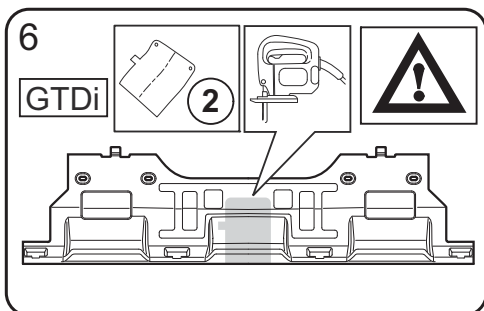
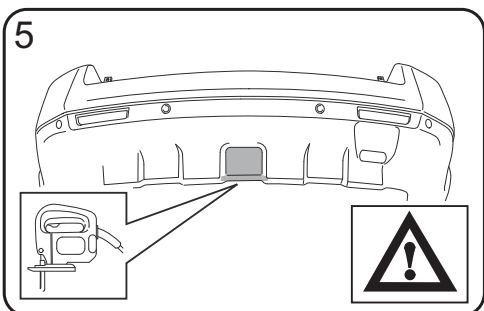
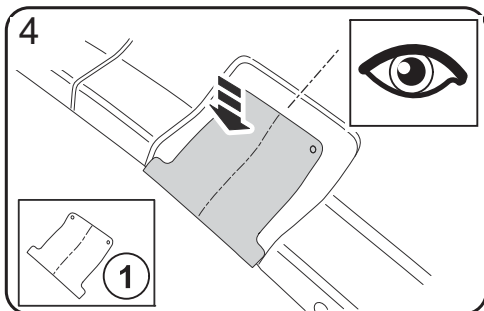
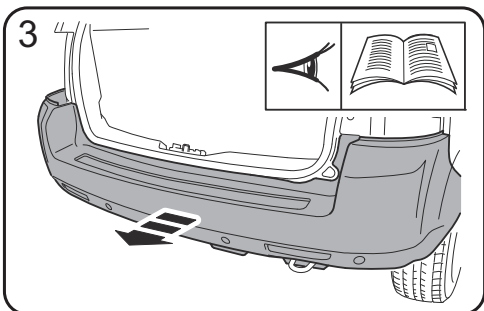
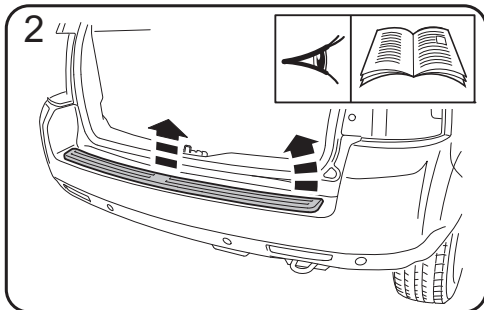
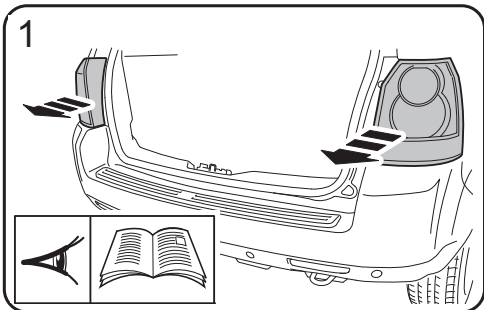

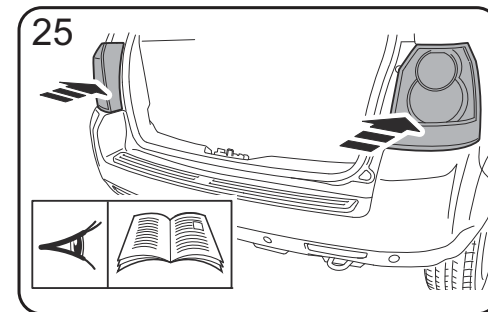
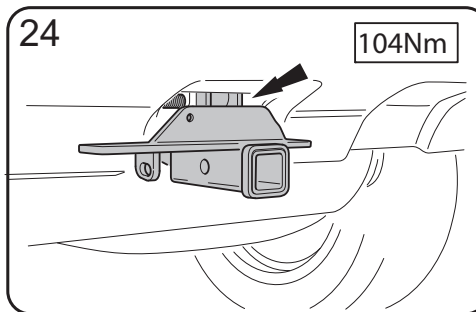
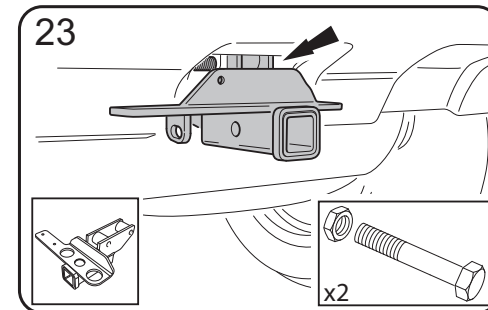
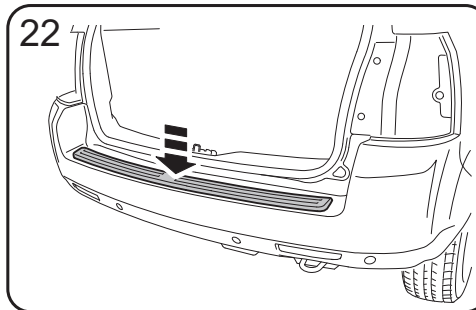
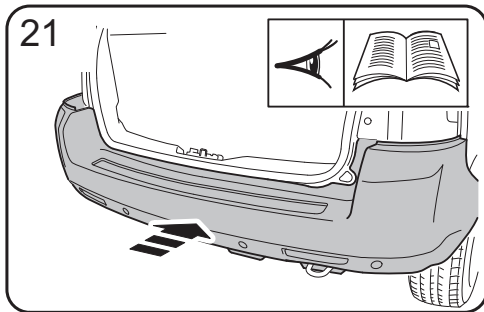
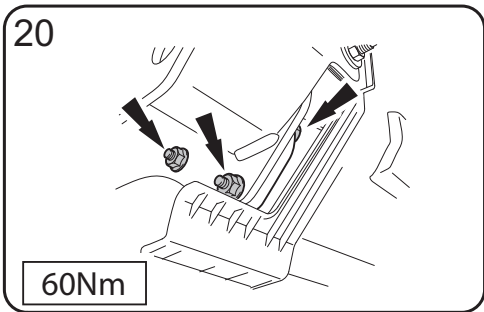
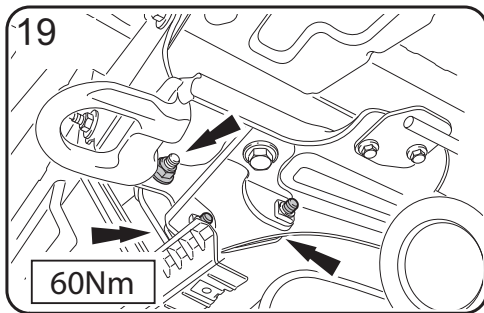
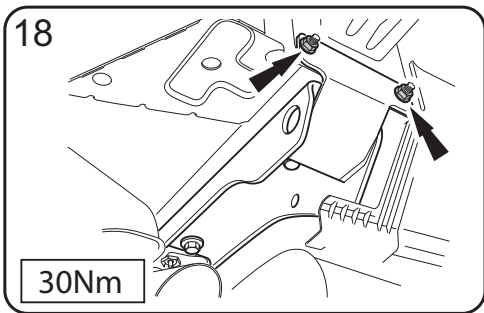
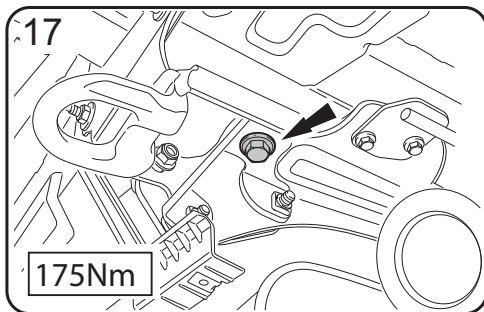
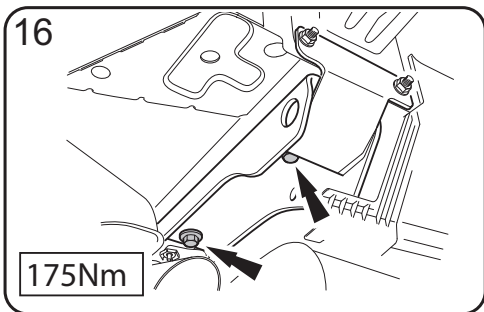
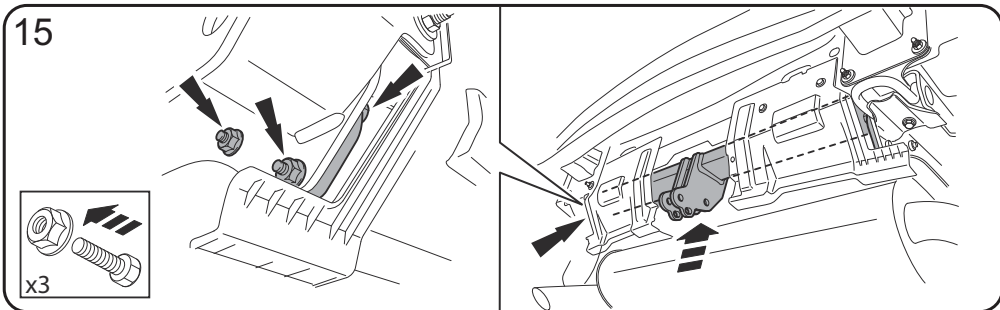

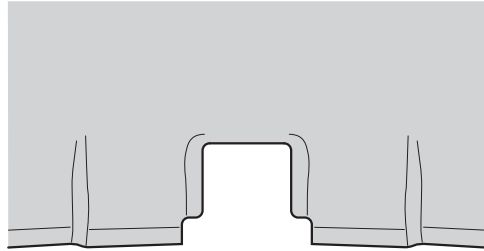

DRILL 2 PLACES DIA 20mm

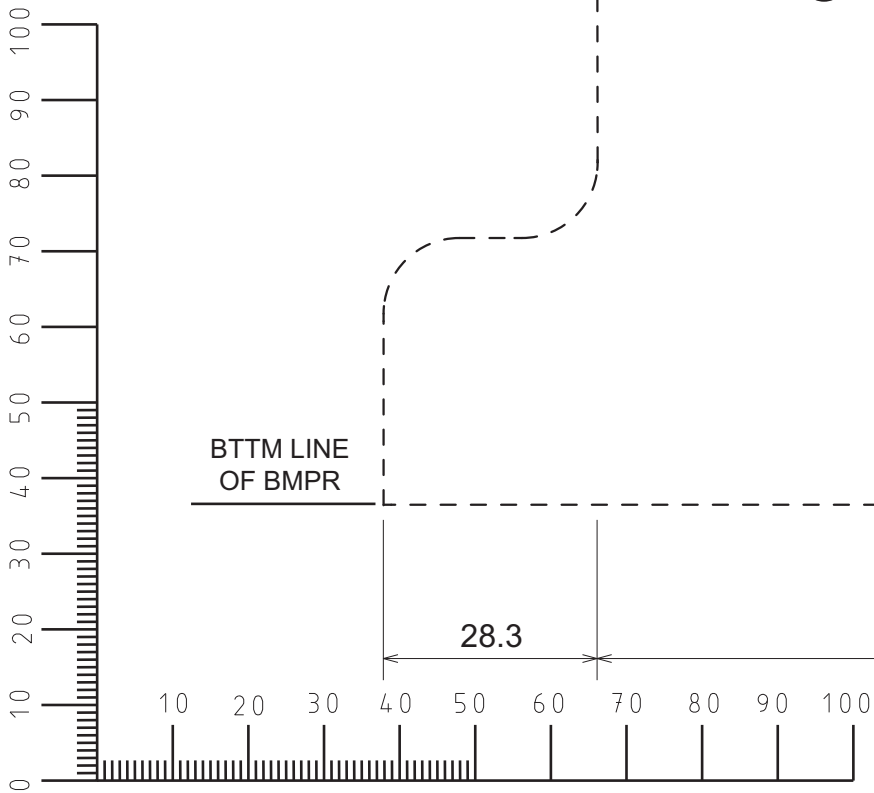

BTTM LINE OF BMPR

1

CL VEHICLE

28.3

122.7

28.3

40.6

142.7

ALL DIMENSIONS IN mm UNLESS OTHERWISE STATED



LAND ROVER

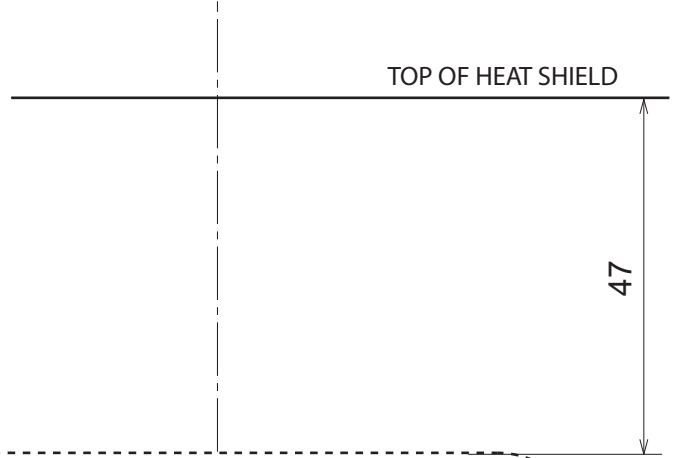
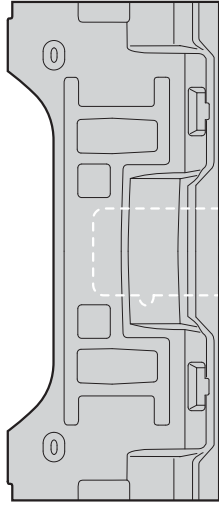
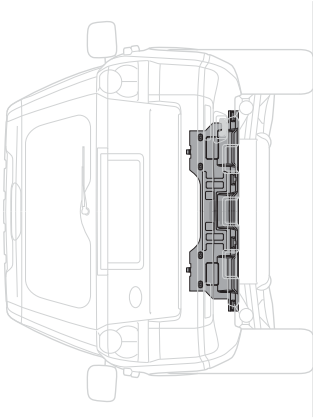

TOP OF HEAT SHIELD

47

DRILL 3 PLACES DIA 20mm

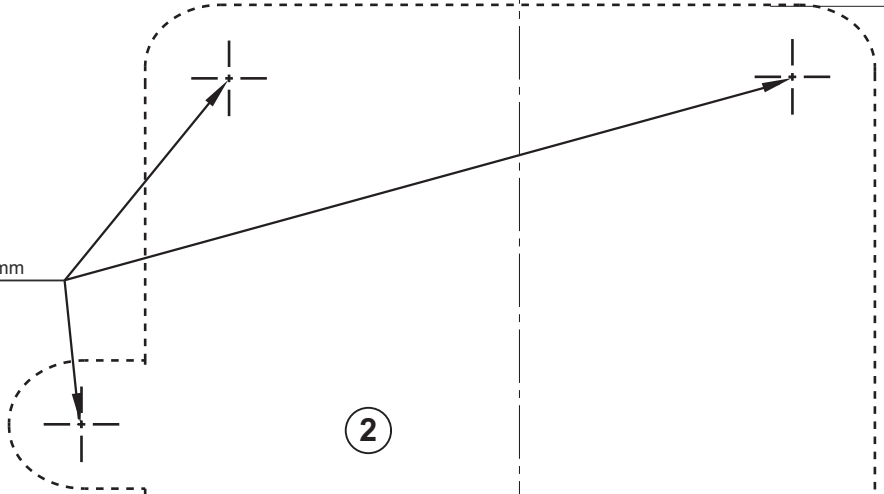

2

CL VEHICLE

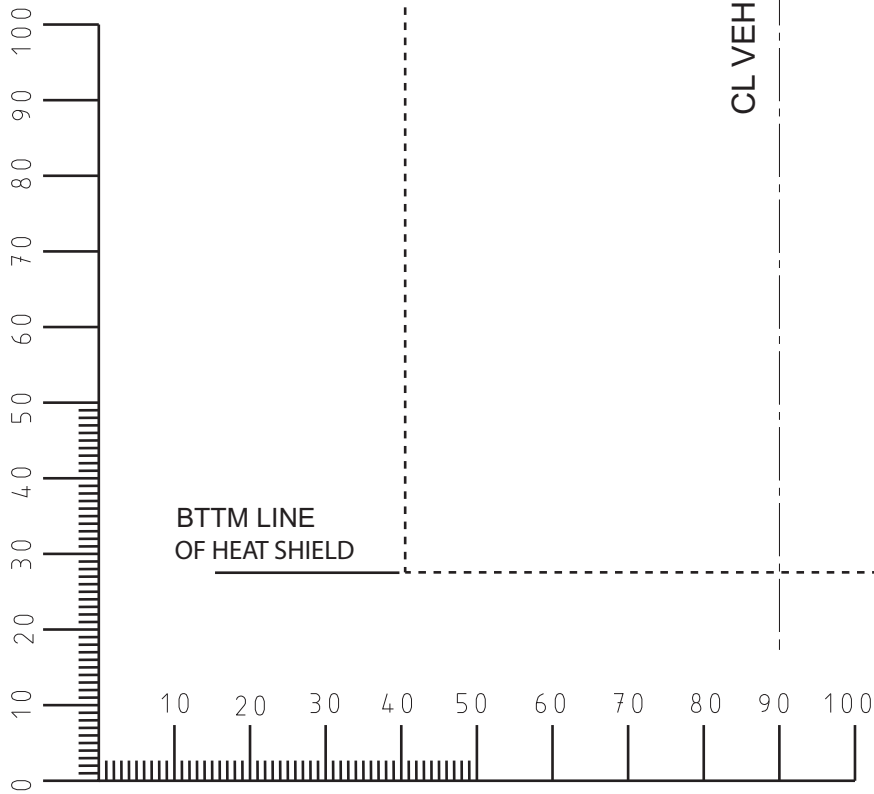

BTTM LINE OF HEAT SHIELD

ALL DIMENSIONS IN mm UNLESS OTHERWISE STATED

LR007482